



DIGITAL MIXING SYSTEM

**RIVAGE**  
PM7

# Block Diagram

# Block Diagram

# System Overview

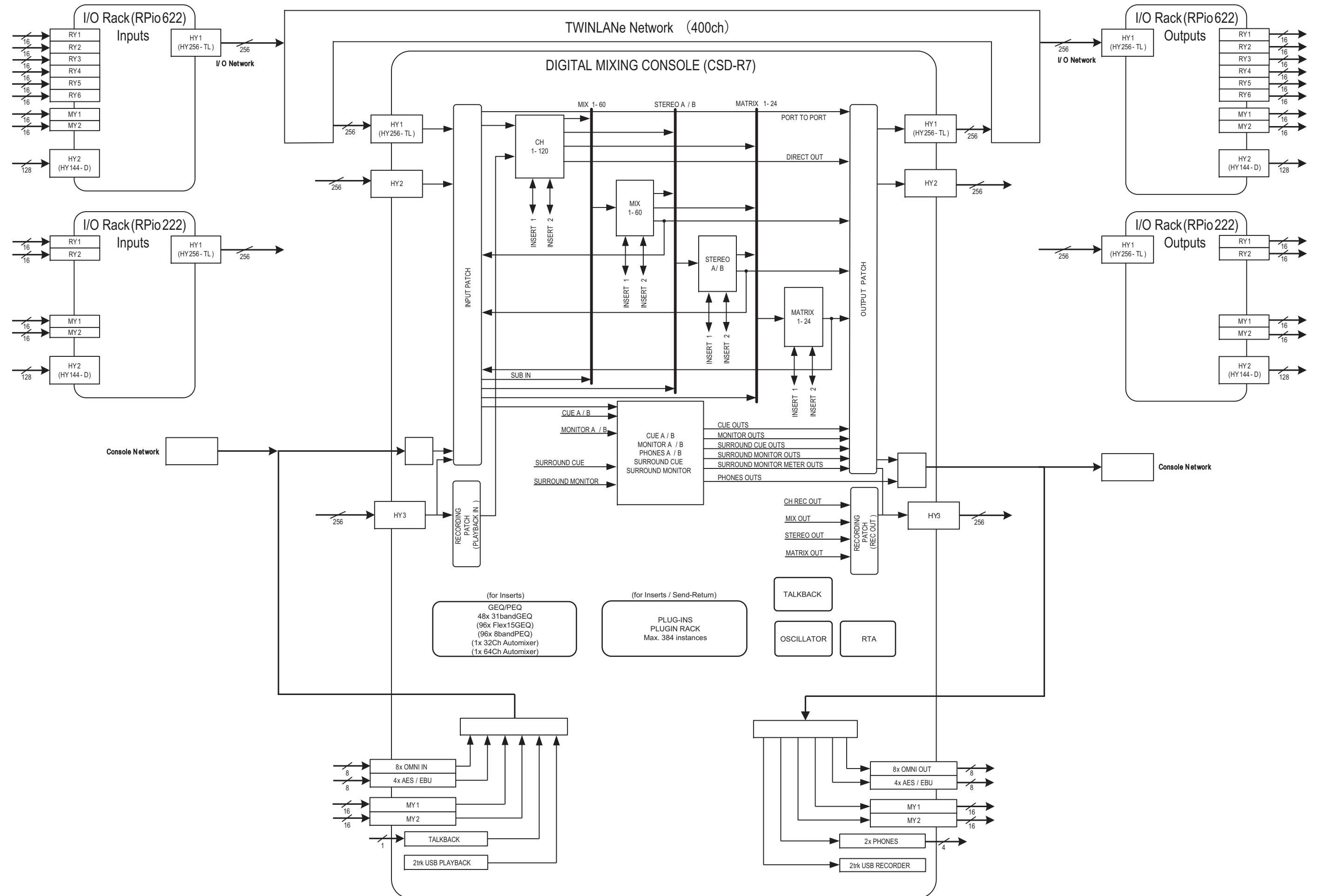

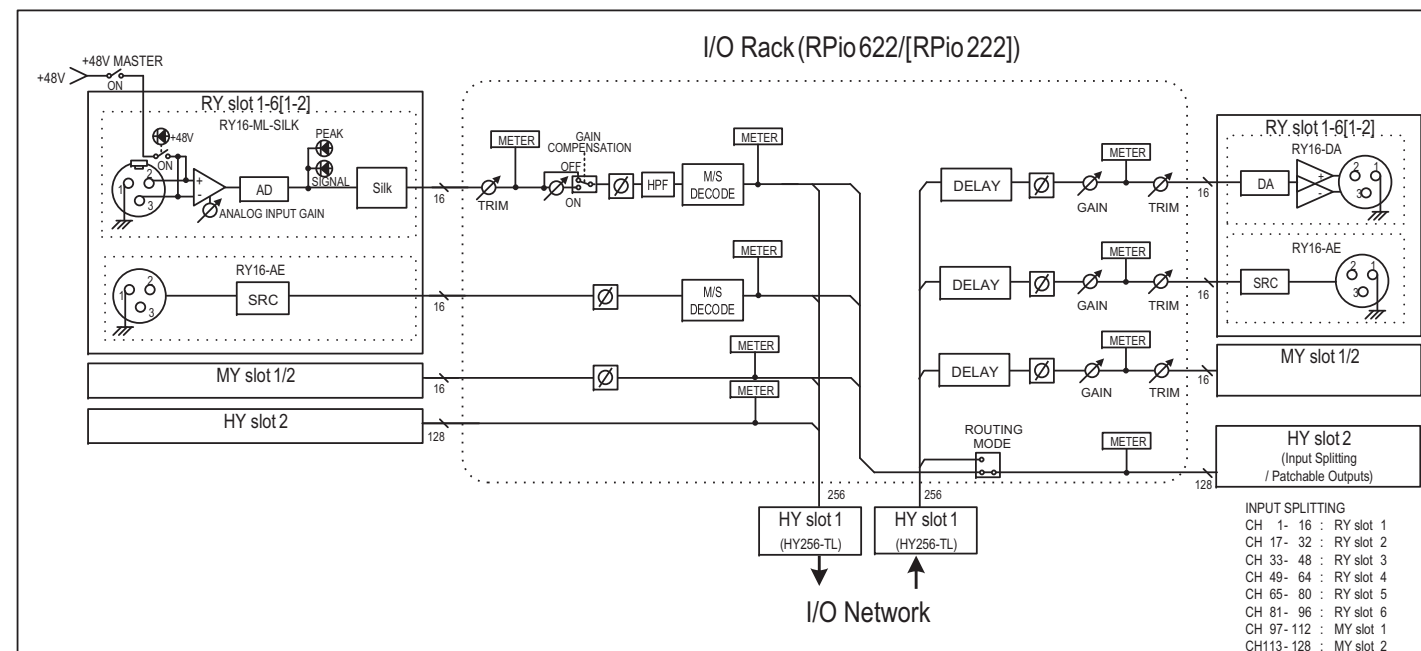
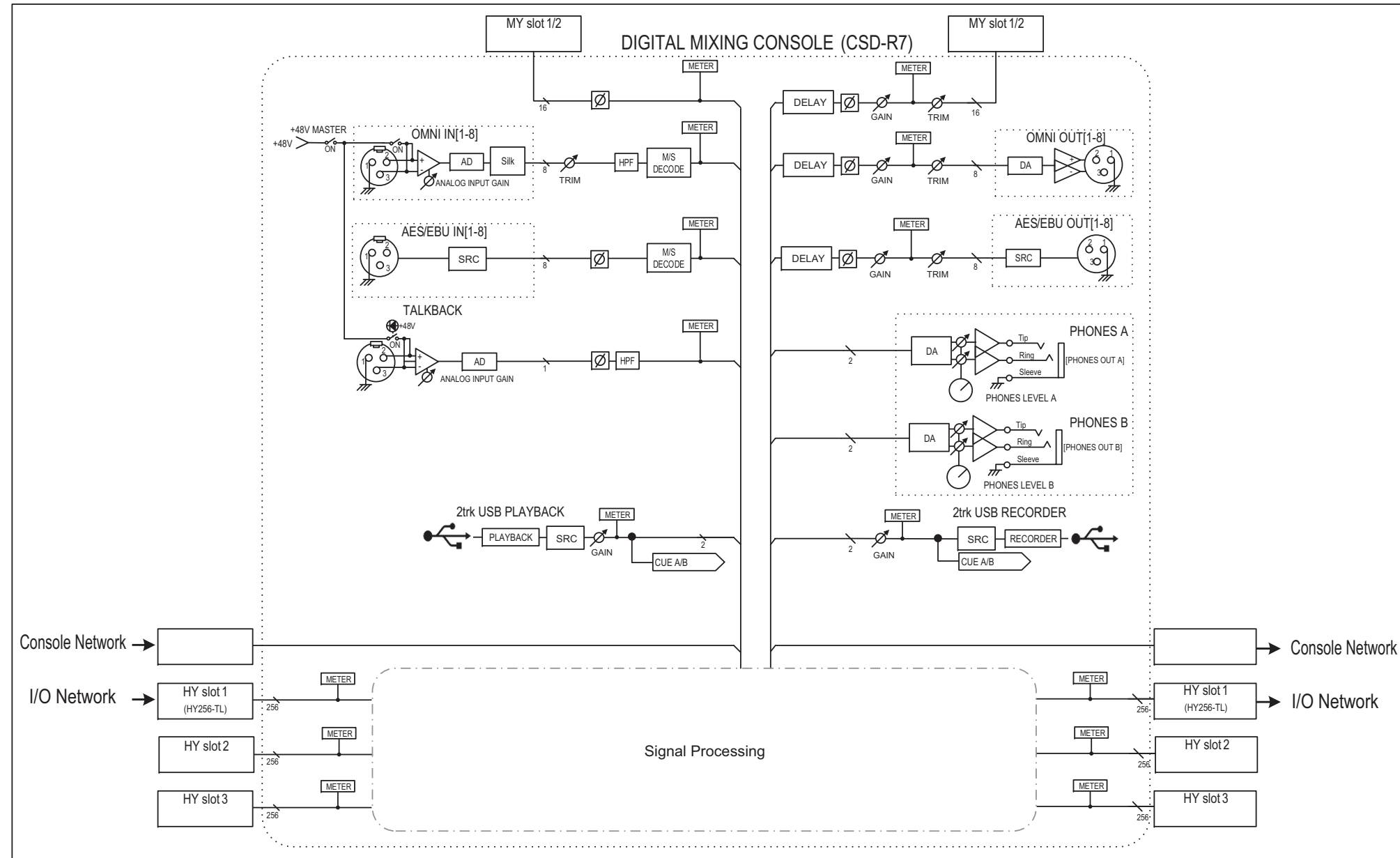

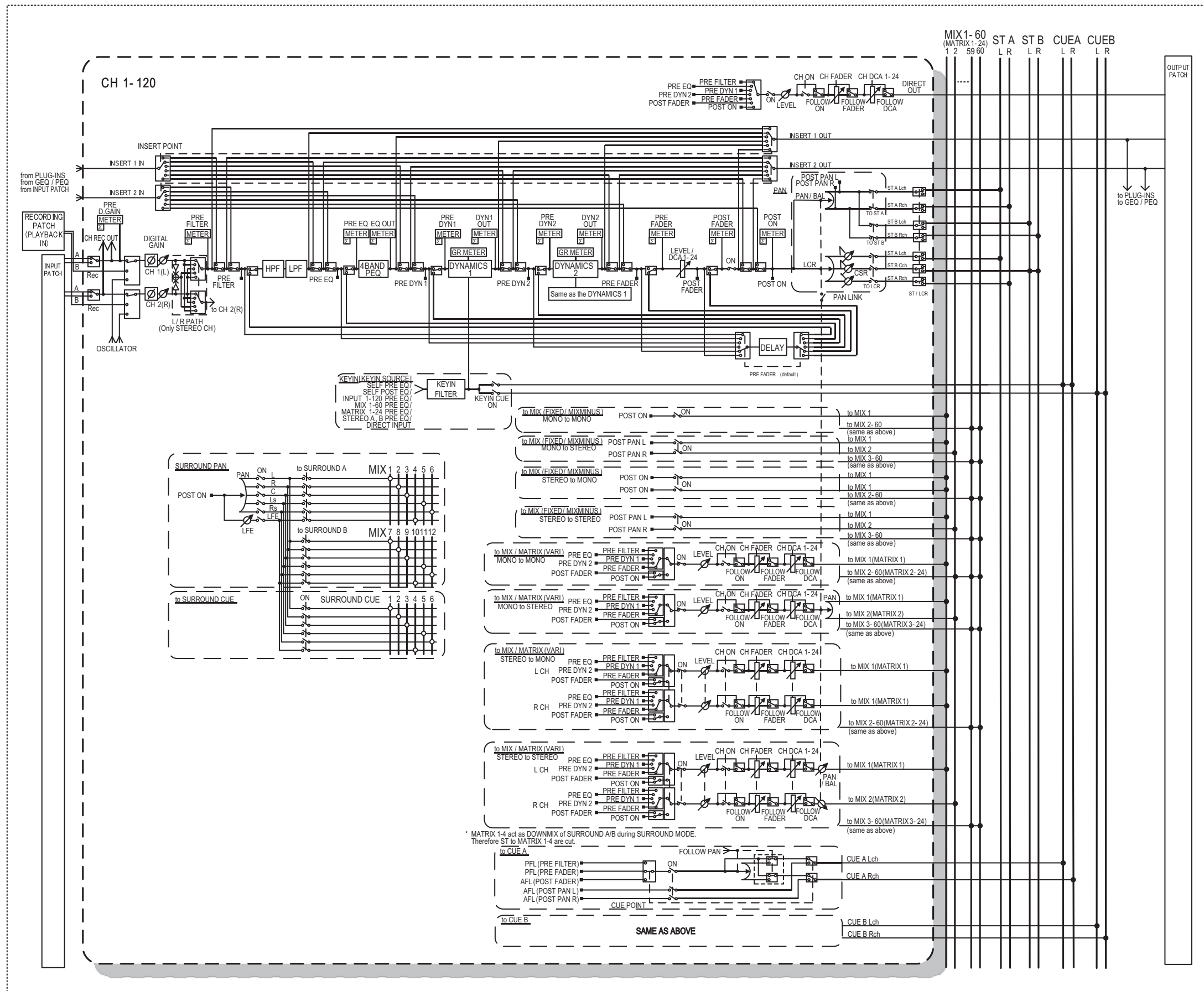

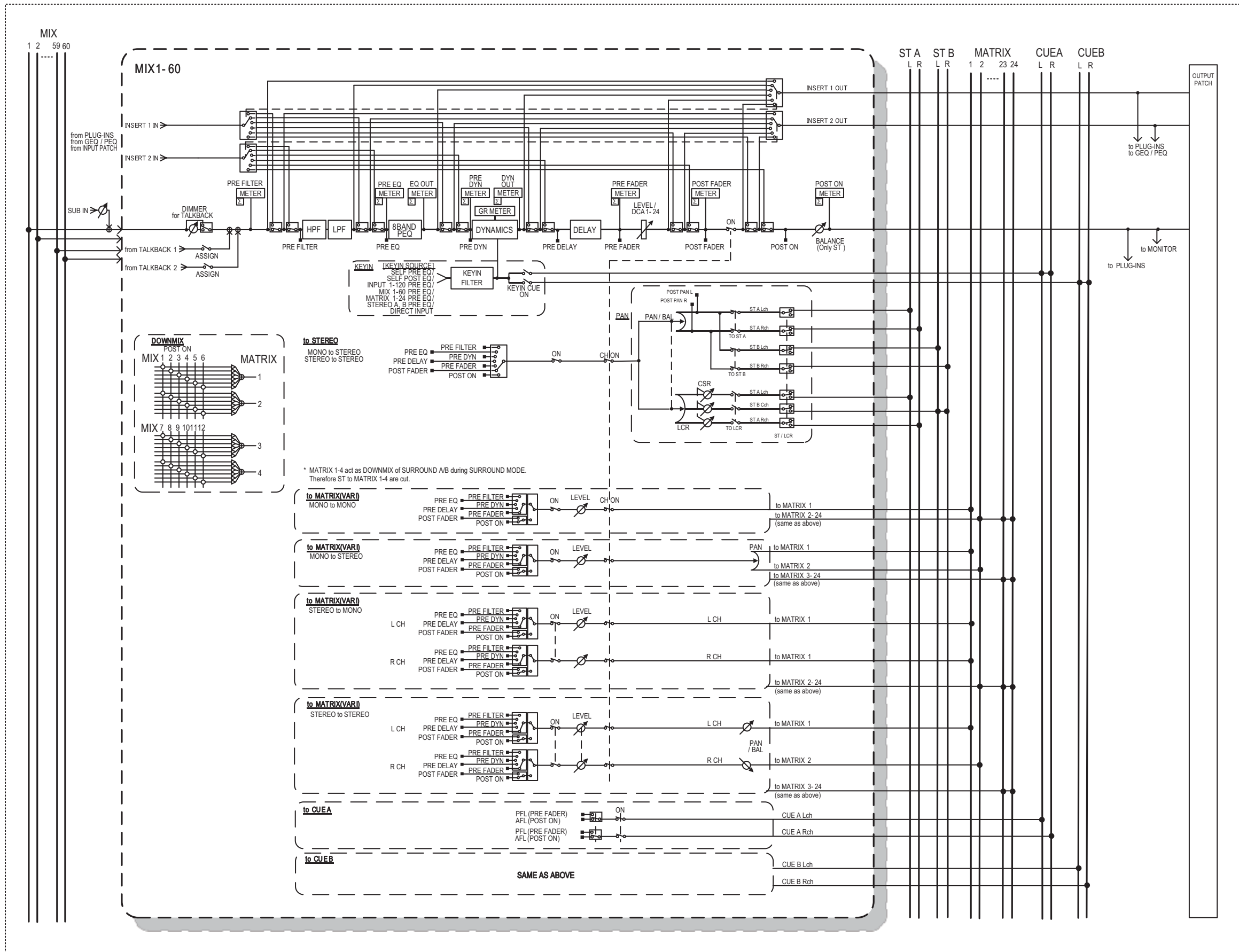

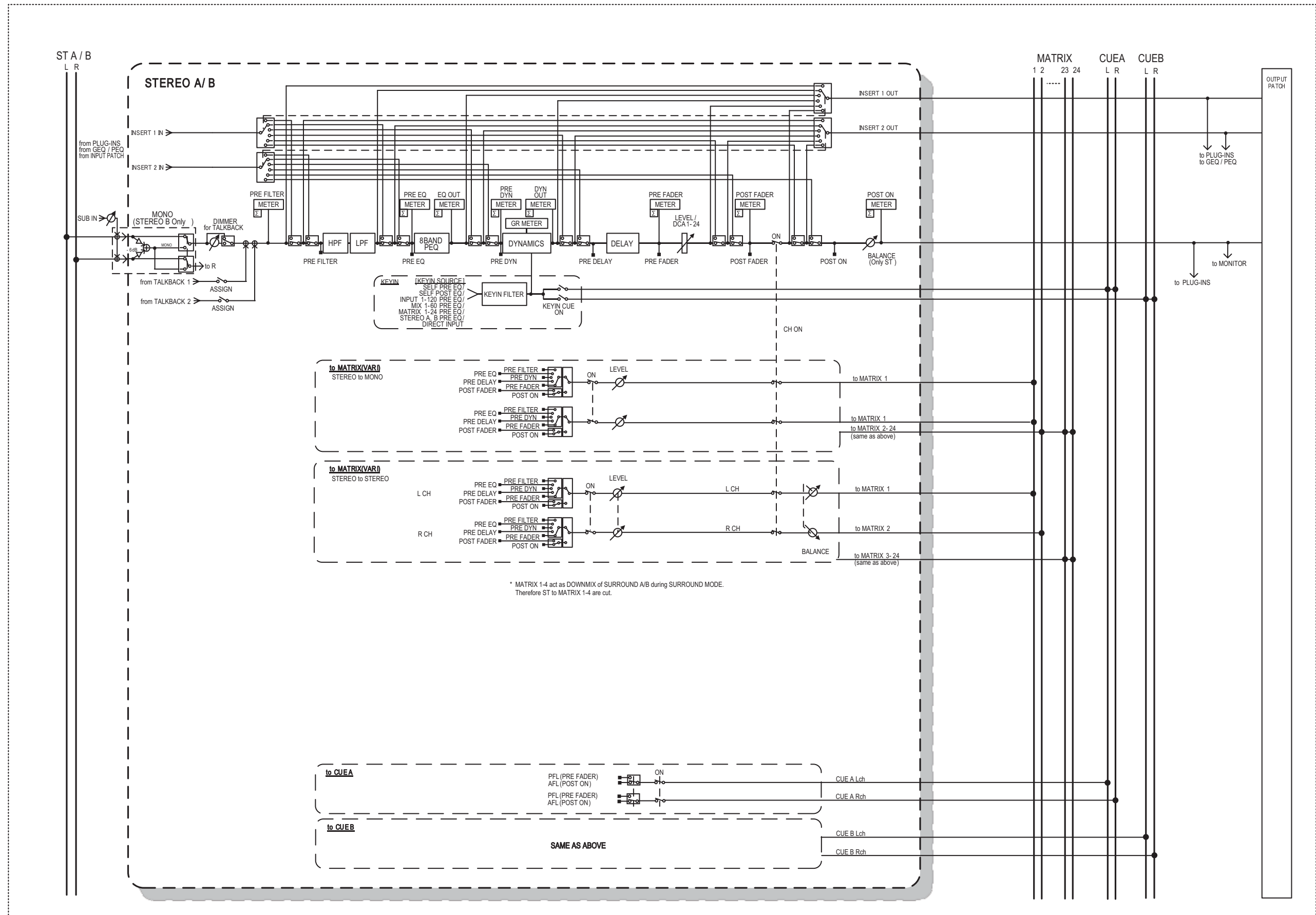

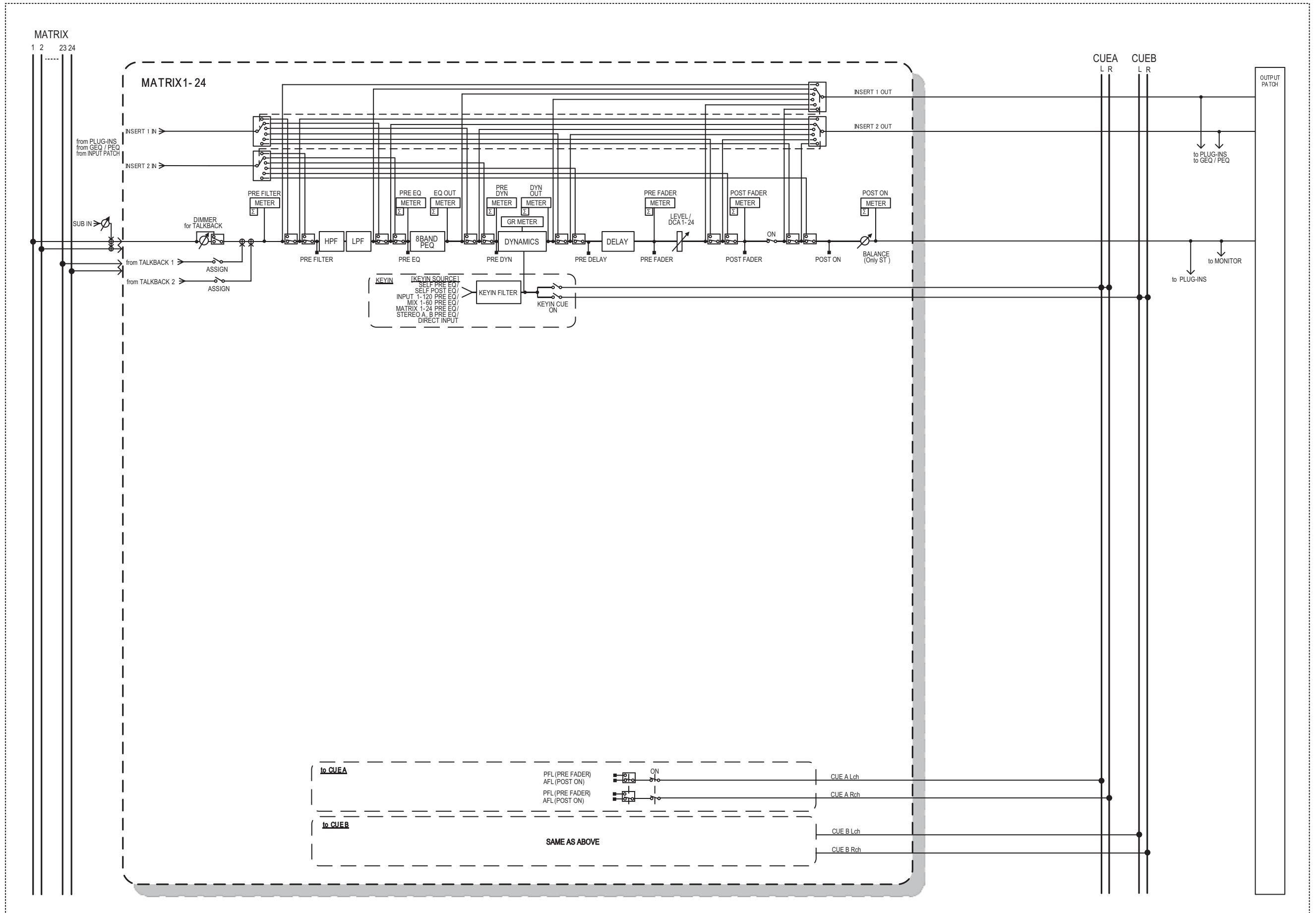

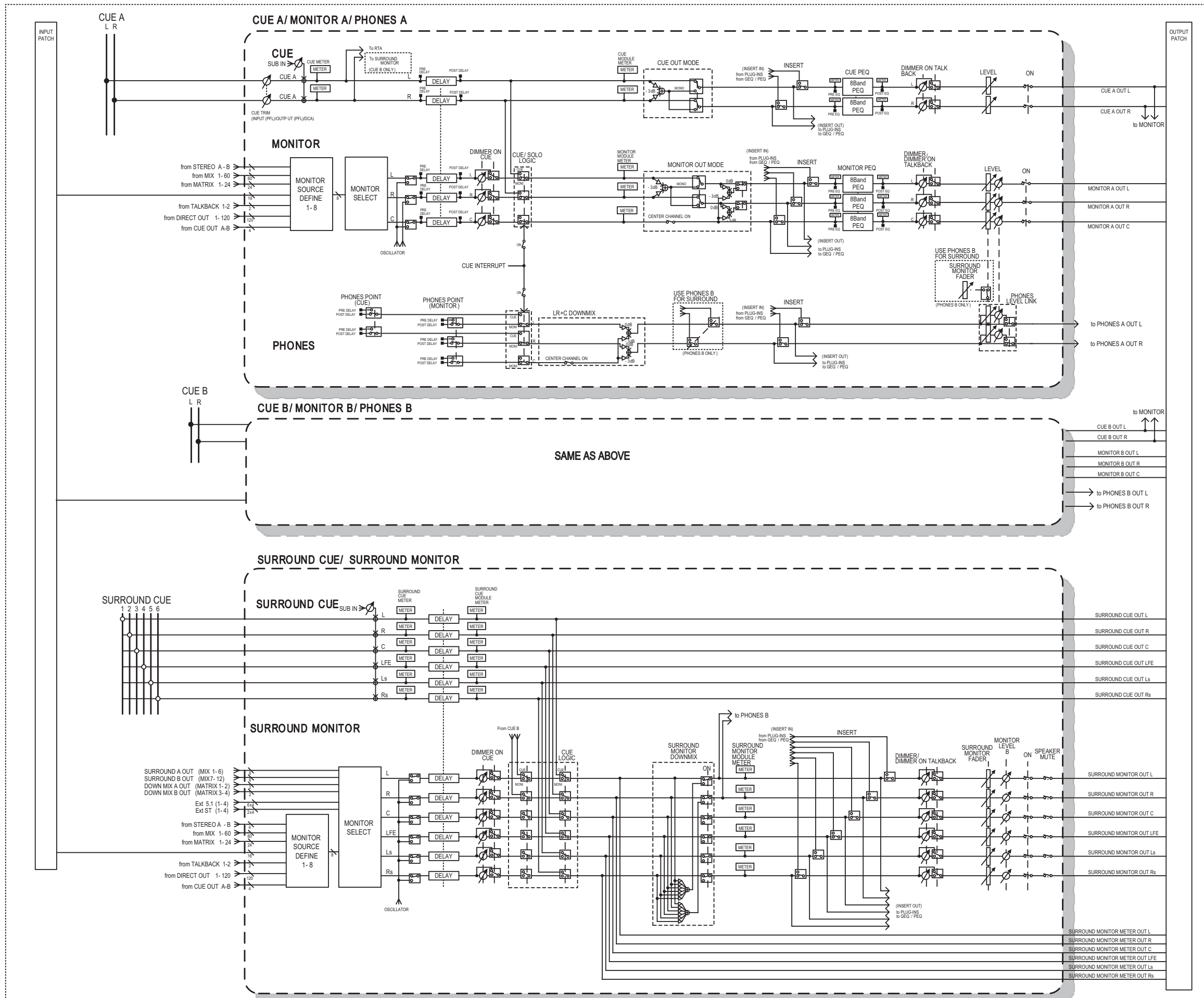



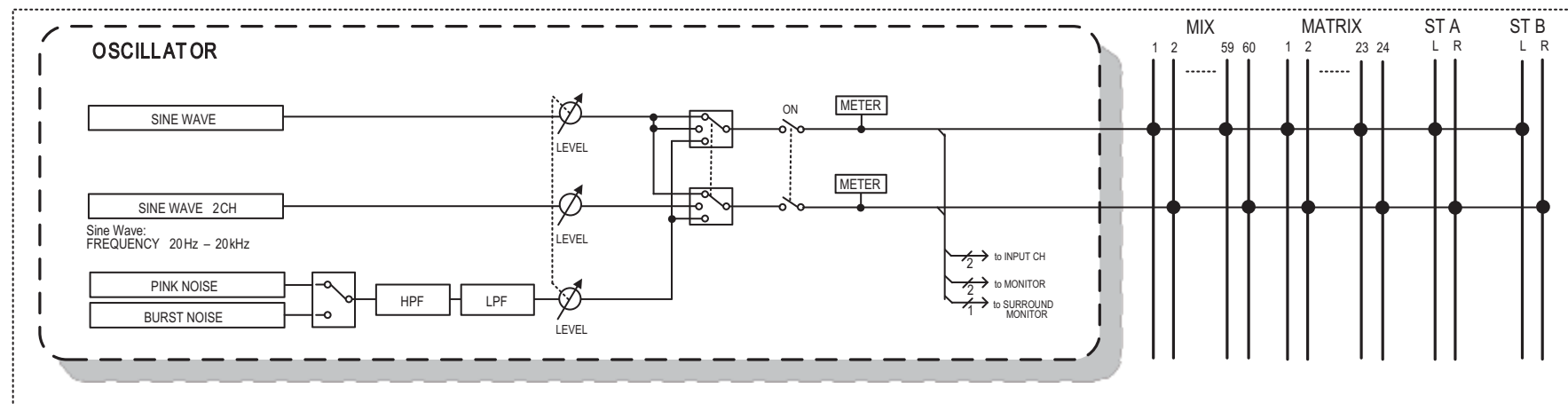
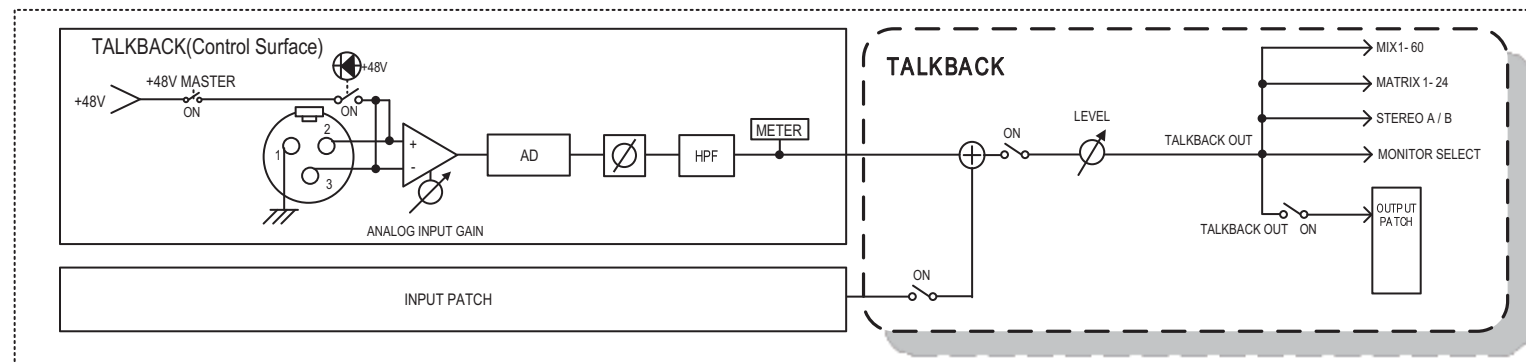
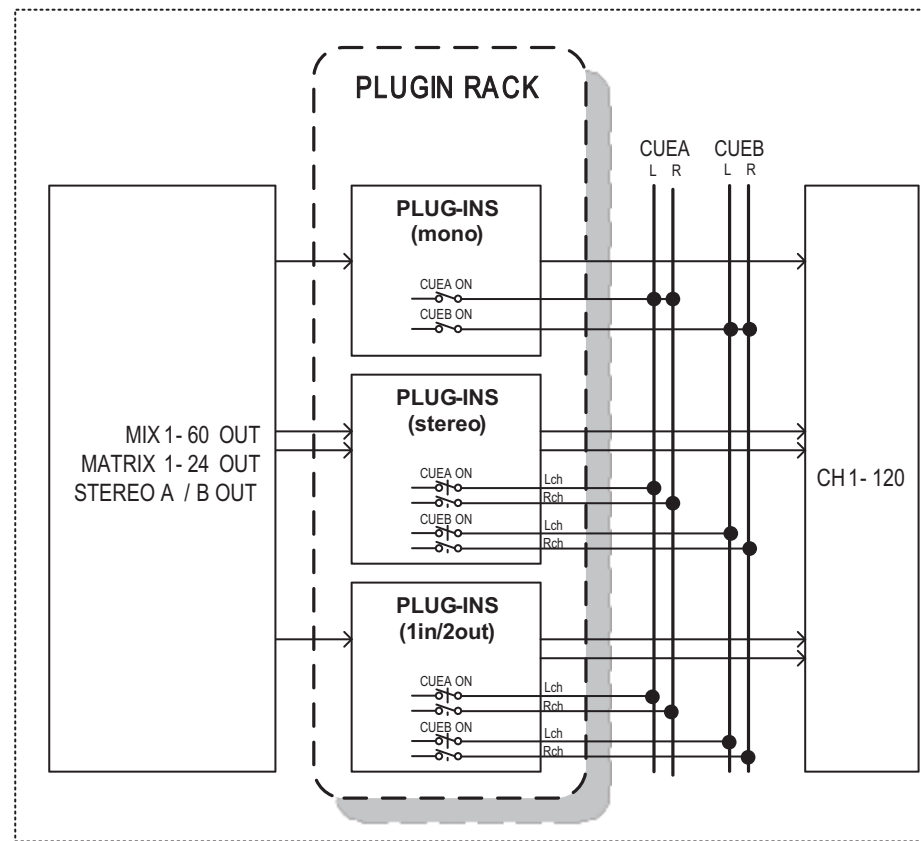

# Level Diagram

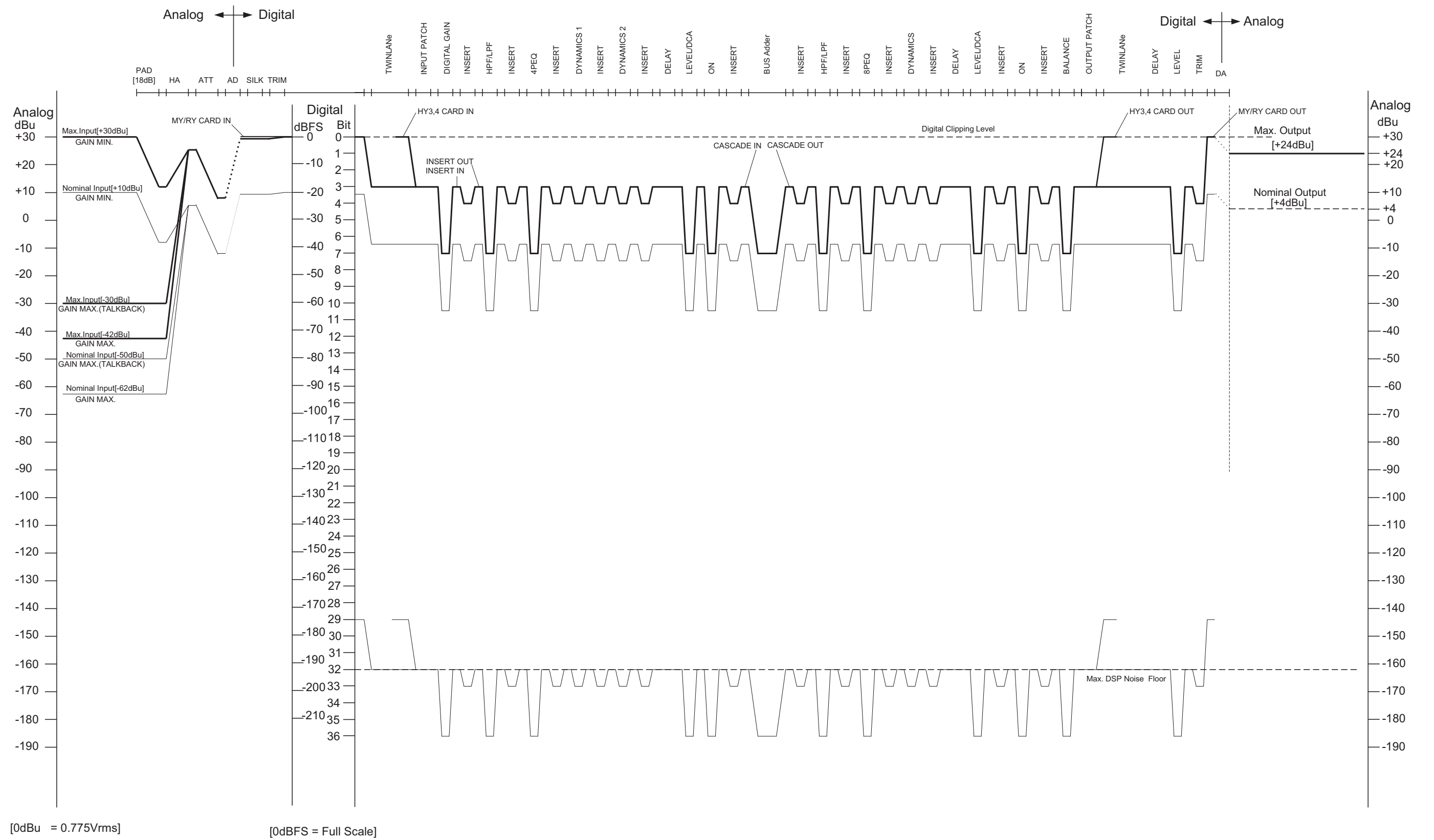

Yamaha Pro Audio global website  
<https://www.yamahaproaudio.com/>  
Yamaha Downloads  
<https://download.yamaha.com/>

Manual Development Group  
© 2018 Yamaha Corporation

Published 01/2019 IPTO-D0

VCQ9090