

SX Series

Subwoofers

User Guide



SX
SERIES



Contents

Click on any section below and it will take you to the relevant page.

Introduction

Approvals.....	6
Unpacking the Units.....	6

SX Series

Introduction.....	7
-------------------	---

SX110

Introduction.....	8
Accessories.....	8
Connections.....	9
Flying SX110.....	9
Specifications.....	10
Technical Drawing.....	10

SX210

Introduction.....	11
Accessories.....	11
Connections.....	12
Flying SX210.....	12
Specifications.....	13
Technical Drawing.....	13

SX112

Introduction.....	14
Accessories.....	14
Connections.....	15
Flying SX112.....	15
Specifications.....	16
Technical Drawing.....	16

SX212

Introduction.....	17
Accessories.....	17
Connections.....	18
Flying SX212.....	18
Specifications.....	19
Technical Drawing.....	19

SXF115

Introduction.....20

Accessories.....20

Connections.....21

Flying SXF115.....21

Wheelboard.....24

Weather Kit.....25

Specifications.....26

Technical Drawing.....26

SXC115

Introduction.....27

Accessories.....27

Connections.....28

Flying SXC115.....28

Castors.....29

Specifications.....30

Technical Drawing.....30

SX118

Introduction.....31

Accessories.....31

Connections.....32

Flying SX118.....32

Transit Covers.....33

Castors.....35

Weather Kit.....36

Specifications.....37

Technical Drawing.....37

SXC118

Introduction.....38

Accessories.....38

Connections.....39

Flying SXC118.....39

Transit Covers.....40

Castors.....42

Weather Kit.....43

Specifications.....44

Technical Drawing.....44

SXCF118

Introduction.....45

Accessories.....45

Connections.....46

Flying SXCF118.....46

Transit Covers.....48

Castors.....49

Weather Kit.....50

Specifications.....51

Technical Drawing.....51

SX218

Introduction.....52

Accessories.....52

Connections.....53

Flying SX218.....54

Transit Covers.....59

Castors.....61

Weather Kit.....62

Specifications.....63

Technical Drawing.....63

SXH218

Introduction.....64

Accessories.....64

Connections.....65

Transit Covers.....66

Weather Kit.....68

Specifications.....69

Technical Drawing.....69

SXHF218

Introduction.....70

Accessories.....70

Connections.....71

Flying SXHF218.....72

Transit Covers.....73

Weather Kit.....75

Specifications.....76

Technical Drawing.....76

SXP118

Introduction.....77

Accessories.....77

Connections.....78

Preset Operation.....81

Dante.....82

VU-NET.....82

Flying SXP118.....83

Transit Covers.....84

Castors.....86

Weather Kit.....87

Specifications.....88

Technical Drawing.....88

SXP218

Introduction.....89

Accessories.....89

Connections.....90

Preset Operation.....93

Dante.....94

VU-NET.....94

Flying SXP218.....95

Transit Covers.....100

Castors.....102

Weather Kit.....103

Specifications.....104

Technical Drawing.....104

Warranty

SX110, SX210, SX112, SX212, SXF115, SXC118, SX118, SXC118, SXCF118, SX218, SXH218, SXHF218.....105

SXP118, SXP218.....105

Introduction

Approvals

This equipment conforms to the requirements of the EMC Directive 89/336/EEC, amended by 92/31/EEC and 93/68/EEC and the requirements of the Low Voltage Directive 72/23/EEC, as amended by 93/68/EEC.

EMC Emission: EN55103-1:2009

EMC Immunity: EN55103-2:2009

Safety: IEC60065:2002 + A2:2010



Unpacking the Units

Every Martin Audio loudspeaker is built to the highest standard and thoroughly inspected before it leaves the factory. After unpacking the system, examine it carefully for any signs of transit damage and inform your dealer if any is found. It is suggested that you keep the original packaging so that the system can be repacked at a future date if necessary. Please note that neither Martin Audio nor its distributors can accept any responsibility for damage to any returned product which arises through the use of non-approved packaging. Please think of our environment. When the product has reached the end of its useful life, please dispose of it responsibly through a recycling centre.



SX Series

Introduction

The SX Series subwoofers are a range of sub bass enclosures designed to complement any of Martin Audio's full range systems. The range encompasses ultra-compact sub-miniature subs perfect as a discreet, unobtrusive installation partner to the ADORN or CDD ranges, right up to very high output twin 18" models perfect for touring use in conjunction with Wavefront Precision line arrays.

The SX Series is suitable for installation or portable applications. Larger models are built to be weather resistant as standard making them suitable for occasional outdoor use as a portable system or for installed systems as long as they are not directly exposed to the elements.

Larger, heavier models are available with optional castors for touring use to make handling as easy as possible.

Two powered, Dante equipped models are available for any applications requiring an active, networked solution. These are an ideal partner to the CDD-LIVE range.

A range of accessories are available including eyebolts for flying the smaller models, a flying frame for the twin 18" SX218 and rugged transit covers.

SX110



Introduction

The SX110 is a slimline subwoofer designed for applications that call for increased impact and low frequency performance in a visually unobtrusive enclosure. Its very small size makes it perfectly suited to installed sound applications where space is limited such as under banquette seating.

It features a 10" (250mm)/2" (50mm) voice coil driver and generously sized low frequency port for reduced air noise. An ideal subwoofer to augment the bass output of ADORN Series or small CDD loudspeakers, it can be used on the ground or flown using integral M8 inserts.

The SX110 enclosure is constructed from plywood and finished in black or white textured paint as standard. An impact-resistant perforated steel grille protects the drivers, and rubber feet on the base resist movement.

When used with Martin Audio full-range systems, crossover and EQ functions can be performed by the DX0.5 system controller.

Accessories

M8 eyebolts HTKCT05

Connections



The SX110 has a pair of NL4 connectors on the rear panel. These are wired in parallel and whilst one is nominally labelled 'INPUT' and the other as 'LINK', connection in and out can be made to either connector. Connection to the drive unit(s) is made to pins 1+/- . There is no internal connection to pins 2+/- although these are linked together so can be used for example to carry a mid/top signal and connected to a full range system using a cable wired with reverse connections (pins 2 to pins 1).

Flying SX110

Eyebolts

The SX110 features M8 inserts to allow flown applications using eyebolts. M8 eyebolts suitable for flown systems are available as accessories from Martin Audio. These are cast steel shouldered eye bolts specifically designed and rated for flown applications. If alternative eyebolts are used these must be cast or machined products stamped with their SWL. Formed steel non-shouldered eyebolts commonly available from DIY stores should not be used under any circumstances as they are not sufficiently load-rated for flown applications.

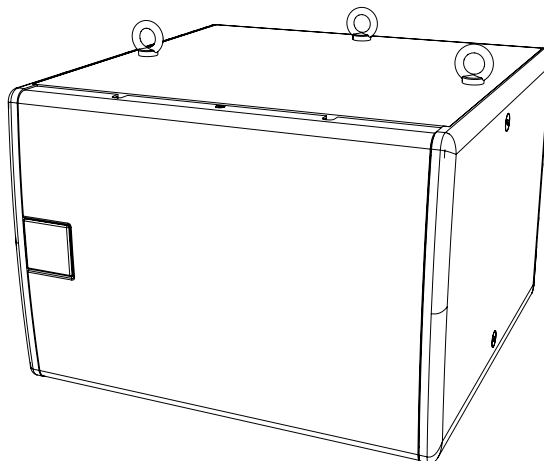

Remove the M8 counter-sunk screws and screw the eyebolts into position. We would recommend three eyebolts and an additional eyebolt as a redundant safety bond. This should be attached to a different point than the other bolts to support the cabinet in the event of the other points failing.

Eyebolts should be connected to a suitably rated fixing point such as a girder clamp or a heavy duty fixing such as a sleeve anchor or similar. They can be linked using suitably rated steel rope or chain and shackles.

Safety note: Flying heavy equipment in public spaces is dangerous and should only be undertaken by suitably qualified and experienced personnel using adequately rated equipment for the task.

Specifications

TYPE	Slimline, direct radiating subwoofer
FREQUENCY RESPONSE (1)	50Hz-150Hz ± 3dB, -10dB @ 42Hz
DRIVER	1 x 10" (250mm)/2" (50mm) voice coil, long excursion, ferrite magnet
RATED POWER (2)	250W AES, 1000W peak
RECOMMENDED AMPLIFIER	VIA2502
SENSITIVITY (10)	97dB
MAXIMUM SPL (9)	121dB continuous, 127dB peak (half space)
NOMINAL IMPEDANCE	8 ohms
DISPERSION (-6dB)	Omnidirectional
CROSSOVER	80-120Hz active
ENCLOSURE	Plywood
FINISH	Black or white
PROTECTIVE GRILLE	Perforated steel
CONNECTORS	2 x NL4
PIN CONNECTIONS (INPUT)	+1, -1 (+2, -2 link through)
PIN CONNECTIONS (LINK)	+1, -1 (+2, -2 link through)
FITTINGS	12 x M8 inserts
DIMENSIONS (INCL FEET)	(W) 417mm x (H) 297mm x (D) 415mm (W) 16.4ins x (H) 11.7ins x (D) 16.3ins
WEIGHT	12kg (26.5lbs)

Notes

- (1) Measured on-axis in half (2pi) space at 2 metres, then referred to 1 metre.
- (2) AES Standard ANSI S4.26-1984.
- (3) Measured in half (2pi) space at 2 metres with 1 watt input, using band limited pink noise, then referred to 1 metre.
- (4) Measured in half (2pi) space at 2 metres using band limited pink noise, then referred to 1 metre.
- (5) Measured on-axis in open (4pi) space at 2 metres, then referred to 1 metre.
- (6) Measured in open (4pi) space at 2 metres with 1 watt input, using band limited pink noise, then referred to 1 metre.
- (7) Measured in open (4pi) space at 2 metres using band limited pink noise, then referred to 1 metre.
- (8) Measured in open (4pi) space at 2 metres with 2.83V input, using band limited pink noise, then referred to 1 metre.
- (9) Calculated at 1 metre.
- (10) Measured in half (2pi) space at 2 metres with 2.83V input, using band limited pink noise, then referred to 1 metre.

Technical Drawing

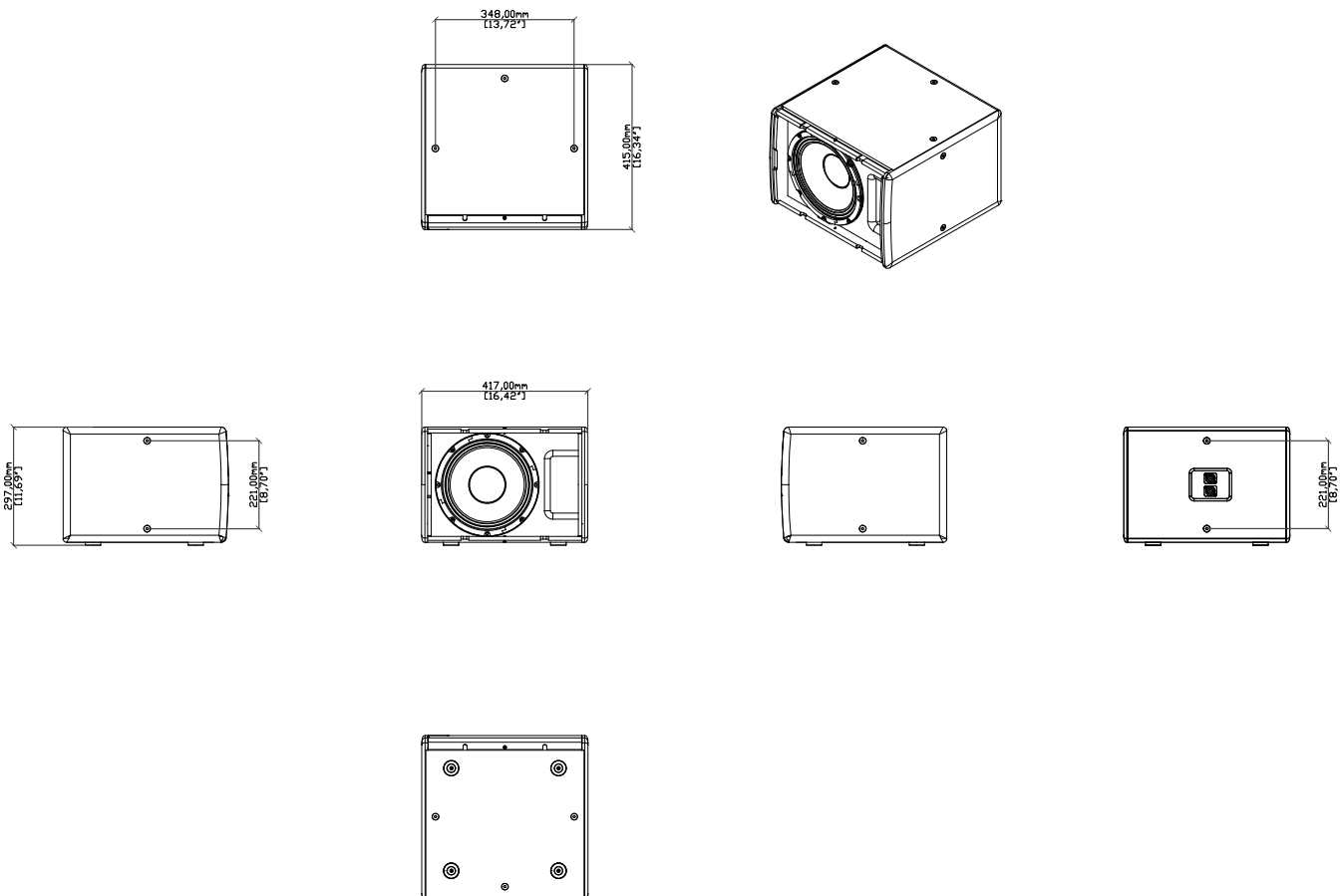

SX210



Introduction

The SX210 is a slimline dual-driver subwoofer designed for situations that call for a visually unobtrusive enclosure. It can be used singly, stacked or flown via integral M8 inserts and its ultra-compact size makes it ideal for applications where space is limited. It features dual 10" (250mm)/2" (50mm) voice coil drivers and generously sized low frequency ports for reduced air noise.

The SX210 enclosure is constructed from plywood and finished in black textured paint as standard, with white and RAL colour finishes available to special order. An impact-resistant perforated steel grille protects the drivers, and the enclosure has twin ergonomic handles at the rear for easy handling. Rubber feet on the base resist movement and align with recesses in the top surface to assist stacking.

When used with full-range systems, crossover and EQ functions can be performed by the DX0.5 or DX4.0 system controller. The recommended amplifier is the VIA 2502, or VIA 5002 or VIA 5004 depending upon the size of the overall system.

Accessories

M8 eyebolts HTKCT05

Connections



The SX210 has a pair of NL4 connectors on the rear panel. These are wired in parallel and whilst one is nominally labelled 'INPUT' and the other as 'LINK', connection in and out can be made to either connector. Connection to the drive unit(s) is made to pins 1+/- . There is no internal connection to pins 2+/- although these are linked together so can be used for example to carry a mid/top signal and connected to a full range system using a cable wired with reverse connections (pins 2 to pins 1).

Flying SX210

Eyebolts

The SX210 features M8 inserts to allow flown applications using eyebolts. M8 eyebolts suitable for flown systems are available as accessories from Martin Audio. These are cast steel shouldered eye bolts specifically designed and rated for flown applications. If alternative eyebolts are used these must be cast or machined products stamped with their SWL. Formed steel non-shouldered eyebolts commonly available from DIY stores should not be used under any circumstances as they are not sufficiently load-rated for flown applications.

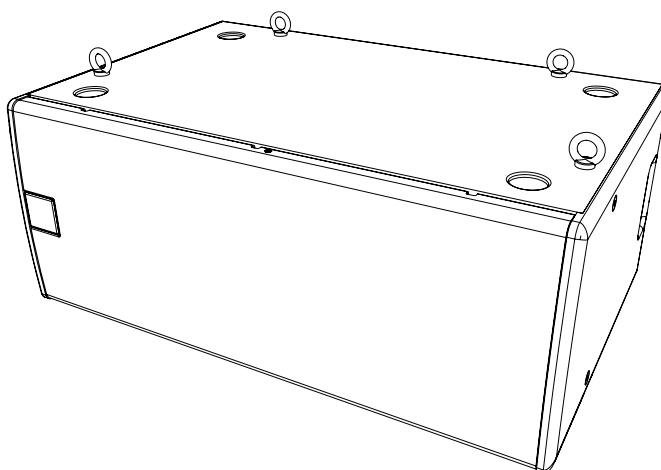

Remove the M8 counter-sunk screws and screw the eyebolts into position. We would recommend four eyebolts and an additional eyebolt as a redundant safety bond. This should be attached to a different point than the other bolts to support the cabinet in the event of the other points failing.

Eyebolts should be connected to a suitably rated fixing point such as a girder clamp or a heavy duty fixing such as a sleeve anchor or similar. They can be linked using suitably rated steel rope or chain and shackles.

Safety note: Flying heavy equipment in public spaces is dangerous and should only be undertaken by suitably qualified and experienced personnel using adequately rated equipment for the task.

Specifications

TYPE	Slimline, direct radiating subwoofer
FREQUENCY RESPONSE (1)	50Hz-150Hz ± 3dB, -10dB @ 42Hz
DRIVER	2 x 10" (250mm)/2" (50mm) voice coil, long excursion, ferrite magnet
RATED POWER (2)	500W AES, 2000W peak
RECOMMENDED AMPLIFIER	VIA2502/5002/5004
SENSITIVITY (10)	103dB
MAXIMUM SPL (9)	127dB continuous, 133dB peak (half space)
NOMINAL IMPEDANCE	4 ohms
DISPERSION (-6dB)	Omnidirectional
CROSSOVER	80-120Hz active
ENCLOSURE	Birch/poplar plywood
FINISH	Black or white
PROTECTIVE GRILLE	Perforated steel
CONNECTORS	2 x NL4
PIN CONNECTIONS (INPUT)	+1, -1 (+2, -2 link through)
PIN CONNECTIONS (LINK)	+1, -1 (+2, -2 link through)
FITTINGS	16 x M8 inserts, 2 x bar handles
DIMENSIONS (INCL FEET)	(W) 720mm x (H) 295mm x (D) 465mm (W) 28.3ins x (H) 11.6ins x (D) 18.3ins
WEIGHT	20kg (44.1lbs)

Notes

- (1) Measured on-axis in half (2pi) space at 2 metres, then referred to 1 metre.
- (2) AES Standard ANSI S4.26-1984.
- (3) Measured in half (2pi) space at 2 metres with 1 watt input, using band limited pink noise, then referred to 1 metre.
- (4) Measured in half (2pi) space at 2 metres using band limited pink noise, then referred to 1 metre.
- (5) Measured on-axis in open (4pi) space at 2 metres, then referred to 1 metre.
- (6) Measured in open (4pi) space at 2 metres with 1 watt input, using band limited pink noise, then referred to 1 metre.
- (7) Measured in open (4pi) space at 2 metres using band limited pink noise, then referred to 1 metre.
- (8) Measured in open (4pi) space at 2 metres with 2.83V input, using band limited pink noise, then referred to 1 metre.
- (9) Calculated at 1 metre.
- (10) Measured in half (2pi) space at 2 metres with 2.83V input, using band limited pink noise, then referred to 1 metre.

Technical Drawing

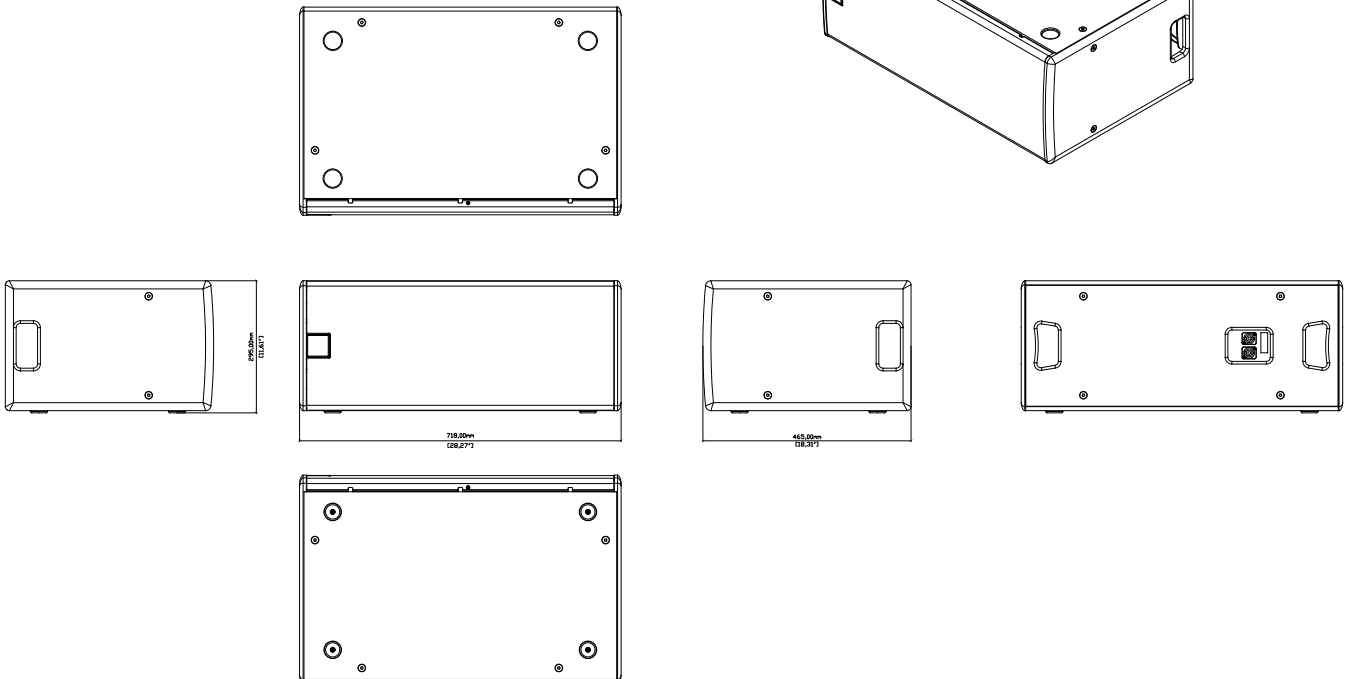
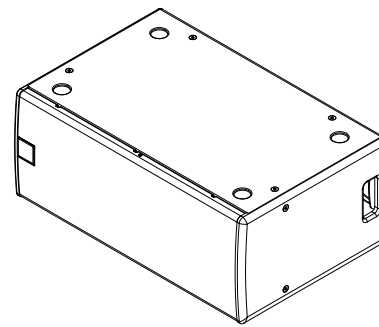

SX112



Introduction

The SX112 is an ultra-compact direct radiating sub-bass system designed to extend the bandwidth and increase the headroom of full-range loudspeaker models. It features a very efficient 12" (300mm) long-throw bass driver with a high power 3" (75mm) voice coil and generously-sized reflex ports for low noise, high power operation.

With a response of 48Hz-150Hz \pm 3dB, the ultra-compact size of the SX112 makes it an ideal partner for ADORN or CDD Series systems where space is at a premium or where the subwoofers need to be hidden. The enclosure is constructed from plywood and has an impact-resistant finish, while the driver is protected by a rigid perforated steel grille, which is pre-curved to withstand physical damage.

Finished in black (RAL9005) or white (RAL9016) as standard with integrated flying points, the SX112 can be also be supplied in any RAL colour to order. When used with full-range systems, crossover and EQ functions can either be performed by the DX0.5 or DX4.0 system controllers.

Accessories

M10 eyebolts HTKCT06

Connections



The SX112 has a pair of NL4 connectors on the rear panel. These are wired in parallel and whilst one is nominally labelled 'INPUT' and the other as 'LINK', connection in and out can be made to either connector. Connection to the drive unit(s) is made to pins 1+/- . There is no internal connection to pins 2+/- although these are linked together so can be used for example to carry a mid/top signal and connected to a full range system using a cable wired with reverse connections (pins 2 to pins 1).

Flying SX112

Eyebolts

The SX112 features M10 inserts to allow flown applications using eyebolts. M10 eyebolts suitable for flown systems are available as accessories from Martin Audio. These are cast steel shouldered eye bolts specifically designed and rated for flown applications. If alternative eyebolts are used these must be cast or machined products stamped with their SWL. Formed steel non-shouldered eyebolts commonly available from DIY stores should not be used under any circumstances as they are not sufficiently load-rated for flown applications.



Remove the M10 counter-sunk screws and screw the eyebolts into position. We would recommend three eyebolts and an additional eyebolt as a redundant safety bond. This should be attached to a different point than the other bolts to support the cabinet in the event of the other points failing.

Eyebolts should be connected to a suitably rated fixing point such as a girder clamp or a heavy duty fixing such as a sleeve anchor or similar. They can be linked using suitably rated steel rope or chain and shackles.

Safety note: Flying heavy equipment in public spaces is dangerous and should only be undertaken by suitably qualified and experienced personnel using adequately rated equipment for the task.

Specifications

TYPE	Ultra-Compact, single driver, direct radiating subwoofer
FREQUENCY RESPONSE (1)	48Hz-150Hz ± 3dB, -10dB @ 35Hz
DRIVER	1 x 12" (300mm)/3" (75mm) voice coil, long excursion, ferrite magnet, waterproof cone
RATED POWER (2)	400W AES, 1600W peak
RECOMMENDED AMPLIFIER	iK81/VIA2502/5002/5004
SENSITIVITY (10)	100dB
MAXIMUM SPL (9)	126dB continuous, 132dB peak (half space)
NOMINAL IMPEDANCE	8 ohms
DISPERSION (-6dB)	Omnidirectional
CROSSOVER	80-120Hz active
ENCLOSURE	Plywood
FINISH	Black or white
PROTECTIVE GRILLE	Perforated steel
CONNECTORS	2 x NL4
PIN CONNECTIONS (INPUT)	+1, -1 (+2, -2 link through)
PIN CONNECTIONS (LINK)	+1, -1 (+2, -2 link through)
FITTINGS	12 x M10 inserts
DIMENSIONS (INCL FEET)	(W) 487mm x (H) 385mm x (D) 410mm (W) 19.2ins x (H) 15.2ins x (D) 16.1ins
WEIGHT	21.5kg (47.3lbs)

Notes

- (1) Measured on-axis in half (2pi) space at 2 metres, then referred to 1 metre.
- (2) AES Standard ANSI S4.26-1984.
- (3) Measured in half (2pi) space at 2 metres with 1 watt input, using band limited pink noise, then referred to 1 metre.
- (4) Measured in half (2pi) space at 2 metres using band limited pink noise, then referred to 1 metre.
- (5) Measured on-axis in open (4pi) space at 2 metres, then referred to 1 metre.
- (6) Measured in open (4pi) space at 2 metres with 1 watt input, using band limited pink noise, then referred to 1 metre.
- (7) Measured in open (4pi) space at 2 metres using band limited pink noise, then referred to 1 metre.
- (8) Measured in open (4pi) space at 2 metres with 2.83V input, using band limited pink noise, then referred to 1 metre.
- (9) Calculated at 1 metre.
- (10) Measured in half (2pi) space at 2 metres with 2.83V input, using band limited pink noise, then referred to 1 metre.

Technical Drawing

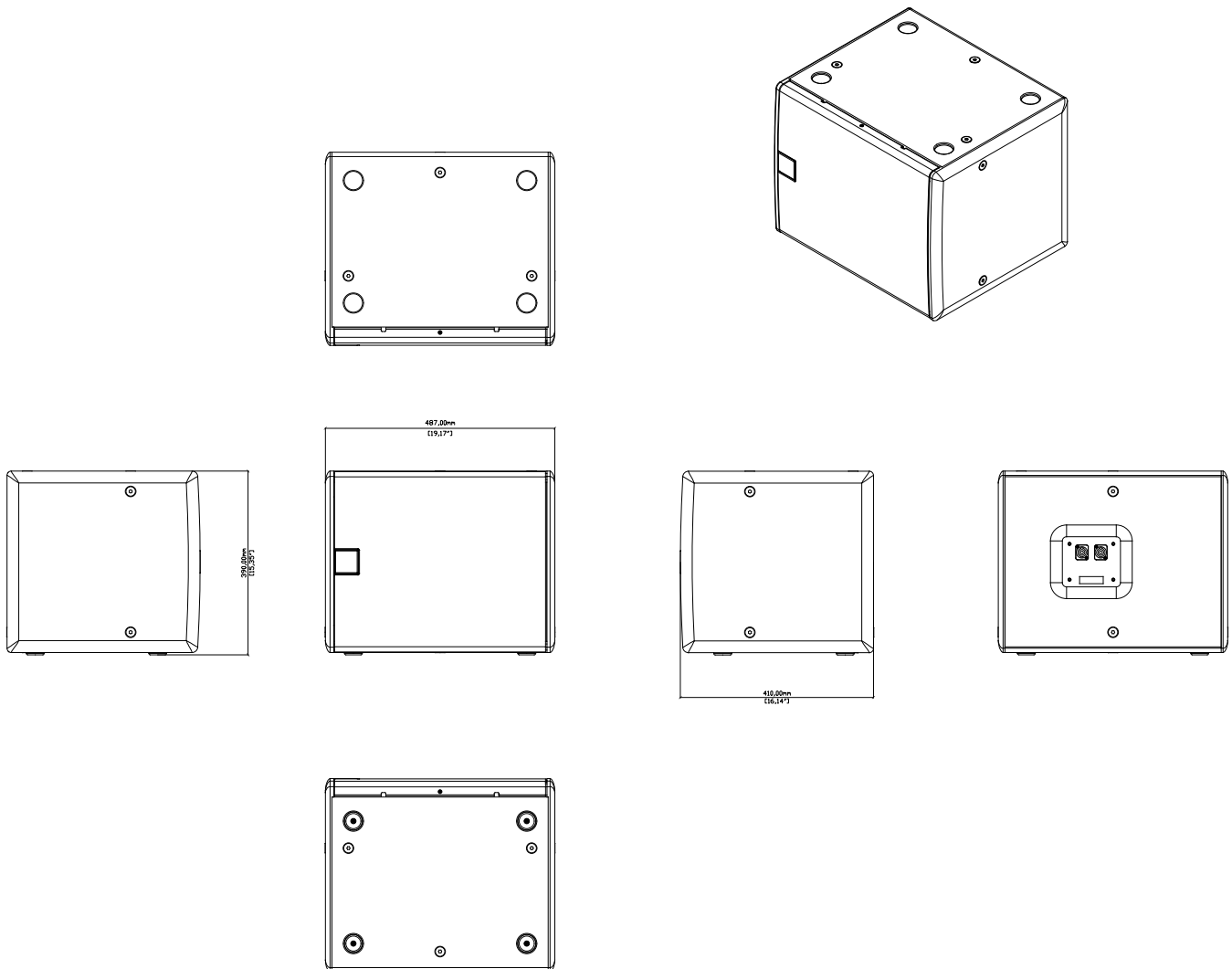

SX212



Introduction

With twin high-efficiency 12" (300mm)/3" (75mm) voice coil long-throw bass drivers and optimally-sized reflex ports to minimise air noise, the SX212 is the perfect sub-bass where low frequency extension and impact is required from a very compact, unobtrusive, low-profile enclosure.

The SX212 is designed to be used with full-range loudspeaker systems and extends the low frequency operating range of the combined system down to 40Hz. The enclosure is constructed from plywood and is internally-braced to reduce energy transmission to the enclosure panels and baffle. Its perforated steel grille is pre-curved to withstand damage and it can be supplied fitted with optional flying points.

Finished in black (RAL9005) or white (RAL9016) as standard with integrated flying points, the SX212 can be also be supplied in any RAL colour to order. When used with full-range systems, crossover and EQ functions can either be performed by the DX0.5 or DX4.0 system controllers.

Accessories

M10 eyebolts HTKCT06

Connections



The SX212 has a pair of NL4 connectors on the rear panel. These are wired in parallel and whilst one is nominally labelled 'INPUT' and the other as 'LINK', connection in and out can be made to either connector. Connection to the drive unit(s) is made to pins 1+/- . There is no internal connection to pins 2+/- although these are linked together so can be used for example to carry a mid/top signal and connected to a full range system using a cable wired with reverse connections (pins 2 to pins 1).

Flying SX212

Eyebolts

The SX212 features M10 inserts to allow flown applications using eyebolts. M10 eyebolts suitable for flown systems are available as accessories from Martin Audio. These are cast steel shouldered eye bolts specifically designed and rated for flown applications. If alternative eyebolts are used these must be cast or machined products stamped with their SWL. Formed steel non-shouldered eyebolts commonly available from DIY stores should not be used under any circumstances as they are not sufficiently load-rated for flown applications.

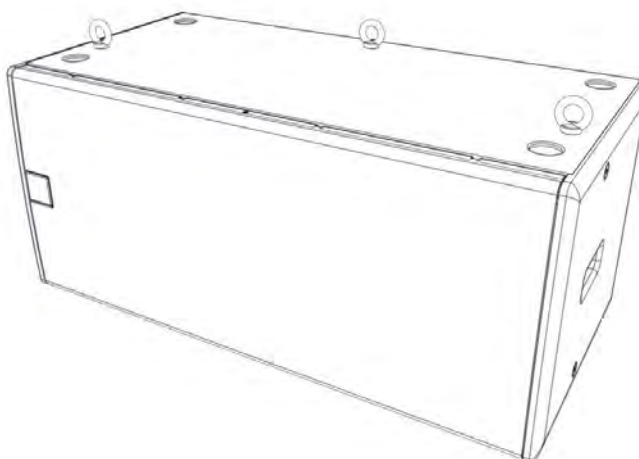

Remove the M10 counter-sunk screws and screw the eyebolts into position. We would recommend three eyebolts and an additional eyebolt as a redundant safety bond. This should be attached to a different point than the other bolts to support the cabinet in the event of the other points failing.

Eyebolts should be connected to a suitably rated fixing point such as a girder clamp or a heavy duty fixing such as a sleeve anchor or similar. They can be linked using suitably rated steel rope or chain and shackles.

Safety note: Flying heavy equipment in public spaces is dangerous and should only be undertaken by suitably qualified and experienced personnel using adequately rated equipment for the task.

Specifications

TYPE	Ultra-Compact, dual-driver, direct radiating subwoofer
FREQUENCY RESPONSE (1)	48Hz-150Hz \pm 3dB, -10dB @ 35Hz
DRIVER	2 x 12" (300mm)/3" (75mm) voice coil, long excursion, ferrite magnet, waterproof cone
RATED POWER (2)	800W AES, 3200W peak
RECOMMENDED AMPLIFIER	iK42/VIA5002/5004
SENSITIVITY (10)	106dB
MAXIMUM SPL (9)	132dB continuous, 138dB peak (half space)
NOMINAL IMPEDANCE	4 ohms
DISPERSION (-6dB)	Omnidirectional
CROSSOVER	80-120Hz active
ENCLOSURE	Plywood
FINISH	Black or white
PROTECTIVE GRILLE	Perforated steel
CONNECTORS	2 x NL4
PIN CONNECTIONS (INPUT)	+1, -1 (+2, -2 link through)
PIN CONNECTIONS (LINK)	+1, -1 (+2, -2 link through)
FITTINGS	12 x M10 inserts
DIMENSIONS (INCL FEET)	(W) 872mm x (H) 385mm x (D) 437mm (W) 34.3ins x (H) 15.2ins x (D) 17.2ins
WEIGHT	39kg (86lbs)

Notes

- (1) Measured on-axis in half (2pi) space at 2 metres, then referred to 1 metre.
- (2) AES Standard ANSI S4.26-1984.
- (3) Measured in half (2pi) space at 2 metres with 1 watt input, using band limited pink noise, then referred to 1 metre.
- (4) Measured in half (2pi) space at 2 metres using band limited pink noise, then referred to 1 metre.
- (5) Measured on-axis in open (4pi) space at 2 metres, then referred to 1 metre.
- (6) Measured in open (4pi) space at 2 metres with 1 watt input, using band limited pink noise, then referred to 1 metre.
- (7) Measured in open (4pi) space at 2 metres using band limited pink noise, then referred to 1 metre.
- (8) Measured in open (4pi) space at 2 metres with 2.83V input, using band limited pink noise, then referred to 1 metre.
- (9) Calculated at 1 metre.
- (10) Measured in half (2pi) space at 2 metres with 2.83V input, using band limited pink noise, then referred to 1 metre.

Technical Drawing

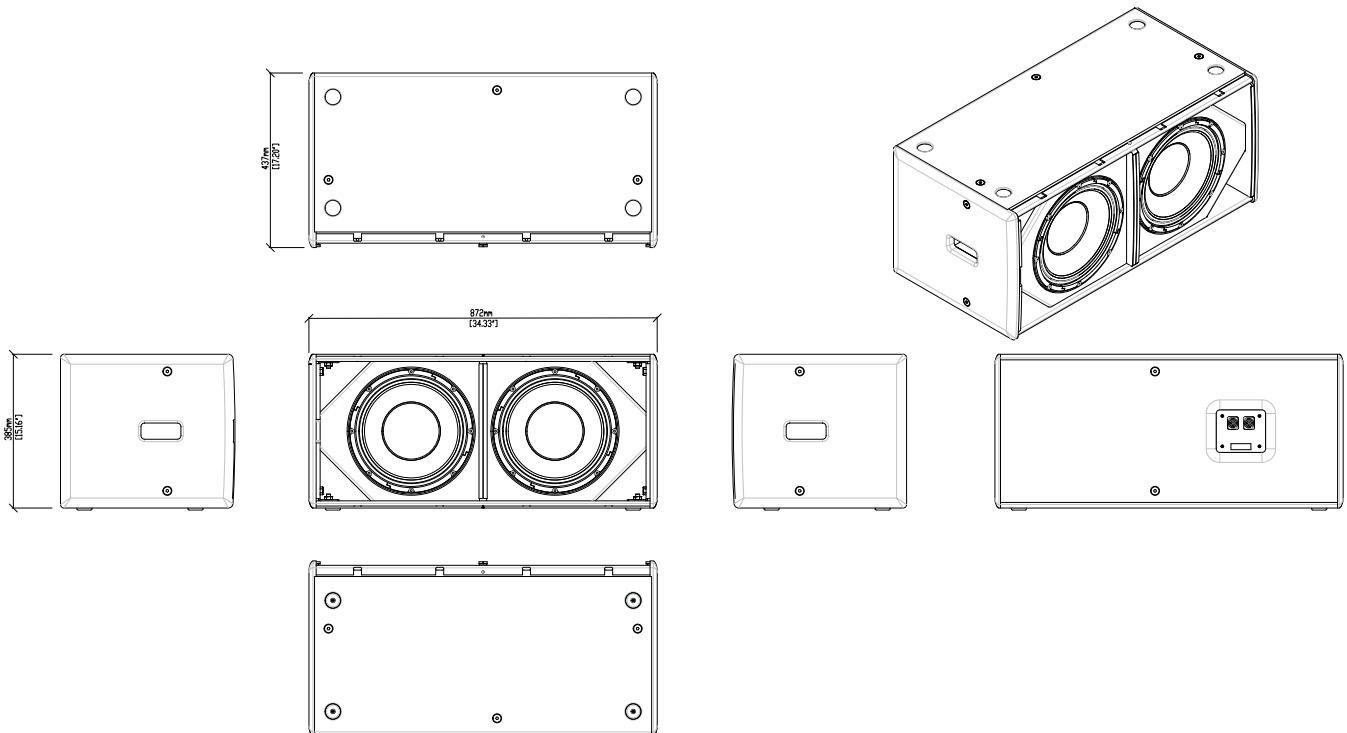

SXF115



Introduction

The SXF115 is a passive subwoofer designed to extend the performance of Martin Audio WPM and MLA Mini systems down to 42Hz. Featuring a powerful, long excursion 15" (380mm)/4" (100mm) voice coil driver in a very compact bass reflex enclosure, it can be flown as part of a WPM or MLA Mini array, or ground-stacked separately.

The design of the 15" driver maximises output while minimising power compression and distortion, and four reflex ports reduce air noise at very high output levels. The SXF115 enclosure is constructed from multi-laminate birch ply, finished with a durable polyurethane coating and equipped with a perforated steel grille, skids and twin bar handles. An M20 threaded fitting in the top surface facilitates pole-mounting of up to 4 WPM or MLA Mini enclosures.

Being a passive subwoofer, the SXF115 is ideal for flown WPM or MLA Mini fixed installations where ground-based, rack-mount amplification is preferred — either for ease of servicing, increased IP protection, or reduced visible cabling in the air.

When used with a WPM or MLA Mini array, Martin Audio iKON amplifiers or the MSX rack-mount power plant respectively deliver the correct drive characteristics to the SXF115, with onboard DSP presets for a variety of system configurations. Cardioid operation can be achieved by arranging the SXF115 in forward and rear-facing pairs.

By adding the input board cover accessory, the subwoofer is fully weather resistant and suitable for permanent outdoor usage.

Accessories

Install flying frame	ASF20054
Touring flying frame	ASF20064 (includes inclinometer & shackles)
Transition grid	WPMMSXGRID
Ground stack base plate	ASF20062
Wheelboard and cover	ASF17025
Wind-up pole	ASF20071
Weather kit	WRKIT

Connections



The SXF115 has a pair of NL4 connectors on the rear panel. These are wired in parallel and whilst one is nominally labelled 'INPUT' and the other as 'LINK', connection in and out can be made to either connector. Connection to the drive unit(s) is made to pins 1+/- . There is no internal connection to pins 2+/- although these are linked together so can be used for example to carry a mid/top signal and connected to a full range system using a cable wired with reverse connections (pins 2 to pins 1).

Flying SXF115

The SXF115 may be flown using the ASF20054 or ASF20064 flying frames which are also used with the MLA Mini system. The ASF20054 is designed for installations, whilst the ASF20064 is fitted with an inclinometer sensor and supplied with shackles making it suitable for touring applications. Deployment of the system is identical with both versions of the flying frame.

With the sub on the floor under the desired position for its final deployment, attach the frame to the chain or motor hoist(s) and raise so it is just above the SXF115. Remove the four flying pins on the bottom of the flying frame to release the drop-down rigging links.

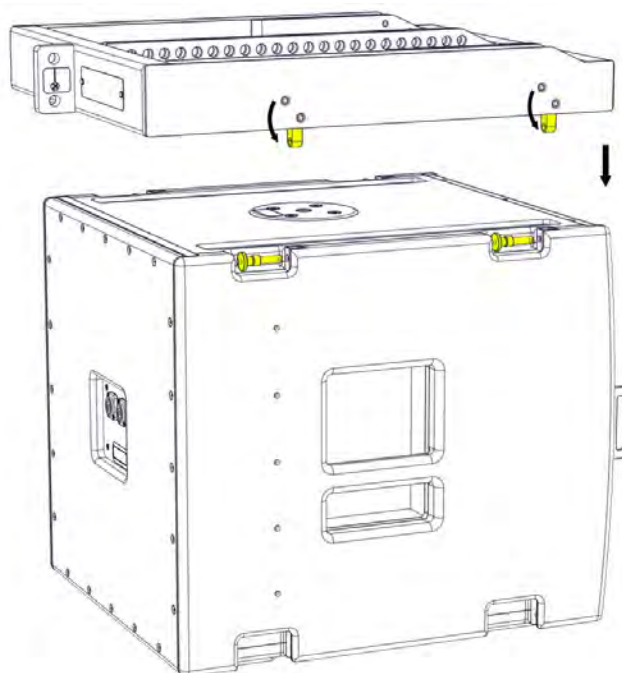

Lower the flying frame onto the sub guiding the four links into the corresponding slots in the top of the sub. Insert flying pins into the four rigging brackets on the sub to lock it to the frame. Ensure that the central button on the flying pin has popped out to ensure that the array is safe.

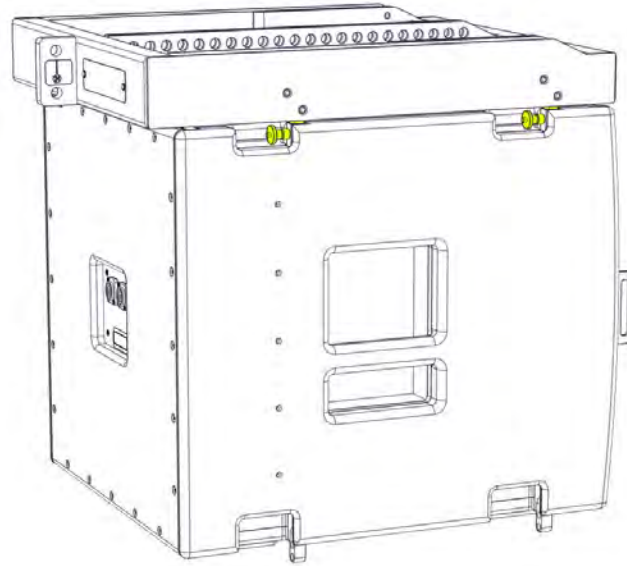

If more subs are to be linked under the first, raise the height of the first sub so you can position a second sub directly under the first. Remove the flying pins in the bottom drop-down rigging links in the first sub and lower it onto the second ensuring that the rigging links engage all four rigging slots in the second sub exactly as you did with the frame and first cabinet.

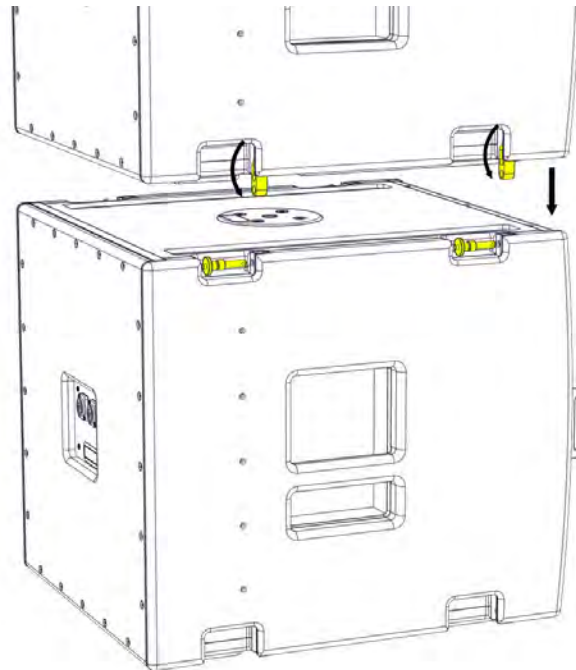

Insert the four flying pins into the rigging brackets on the second SXF115 ensuring that the pins are correctly engaged.

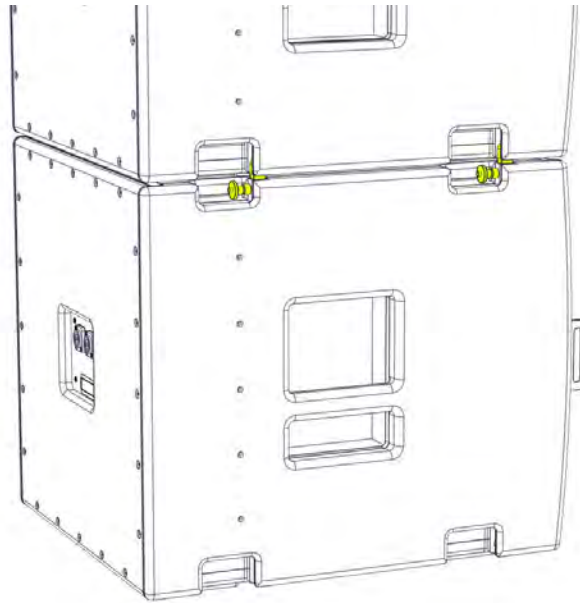

More cabinets can be added as required or transition frames connected to enable flying of either MLA Mini or WPM arrays under the SXP115. For more details see the User Guides for MLA Mini and WPM.

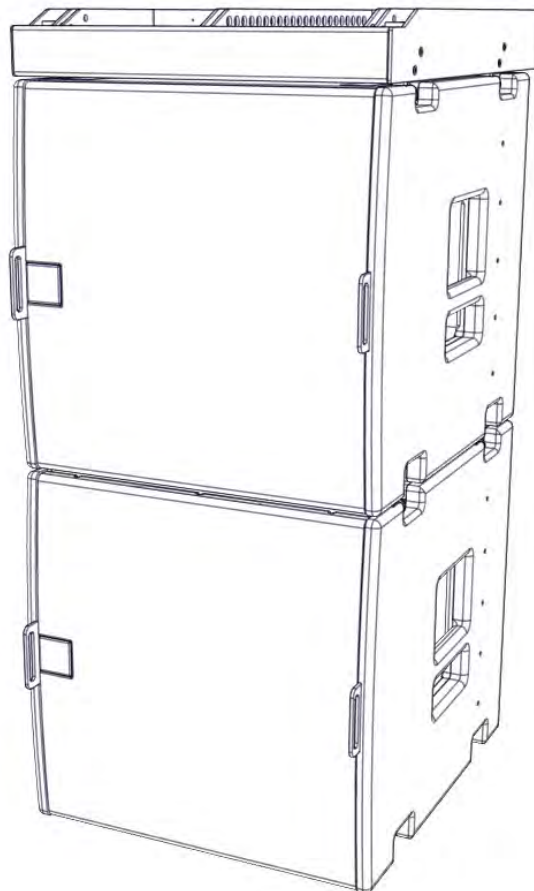

Wheelboard

The SXF115 uses a front mounted wheelboard and travels face-down. The transit cover drops over the top of the cabinet once it is on the wheelboard.

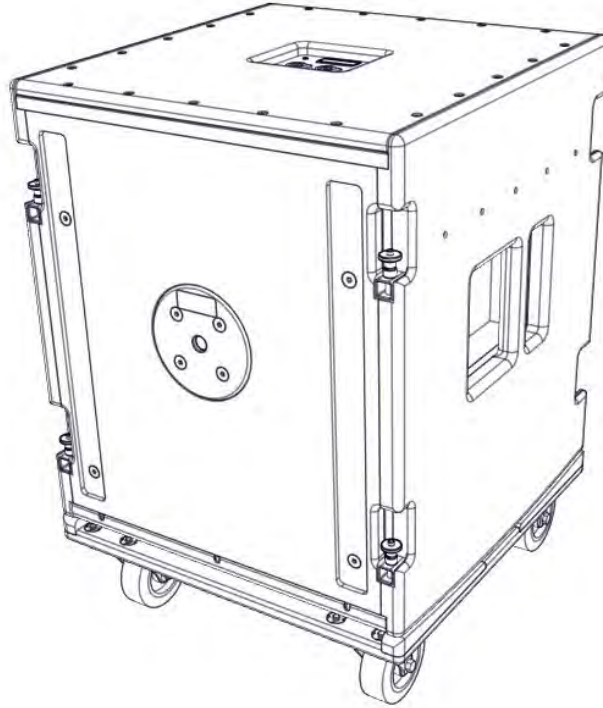

Weather Kit

The WRKIT for non-powered SX Series subwoofers is a glanded cover which fits over the connection panel to prevent water ingress protecting the NL4 speaker connection.

The cable entry may be through one of two knock-out positions depending the angle from which you wish the cable to enter. First remove the knock-out blank that you wish to use and fit the cable gland in position. Note that to use the WRKIT it is necessary to remove the NL4 connector from your speaker cable so the cable can be fed through the cable gland. Once the cable has been threaded through the gland the NL4 can be re-attached.

Remove the four counter-sunk screws in the connector panel and position the cover on the connector panel. Connect the NL4 to the input connector and position the cover, pulling the slack in the speaker cable as you lower the cover in position. Secure the cover using the four M4 x 25 cap socket screws and fibre washers. Finally tighten the gland to ensure a waterproof seal.

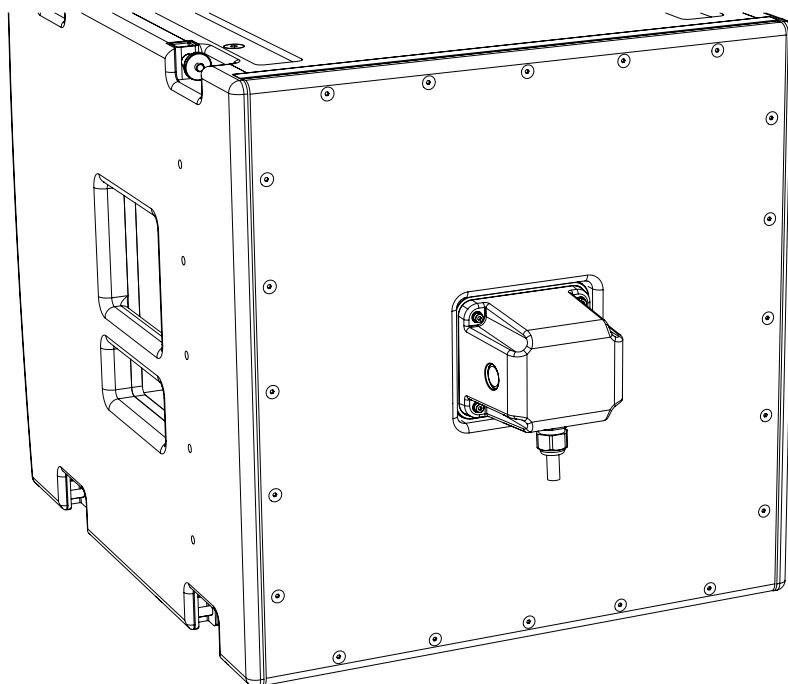
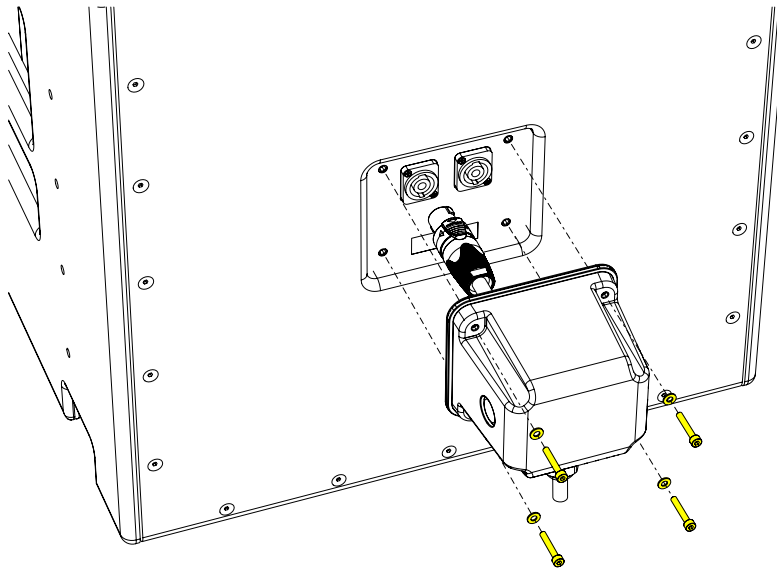

Specifications

TYPE	Compact, single driver, direct radiating subwoofer
FREQUENCY RESPONSE (1)	50Hz-150Hz ± 3dB, -10dB @ 42Hz
DRIVER	1 x 15" (300mm)/4" (100mm) voice coil, ultra-long excursion, ferrite magnet
RATED POWER (2)	800W AES, 3200W peak
RECOMMENDED AMPLIFIER	iK42/81
SENSITIVITY (10)	103dB
MAXIMUM SPL (9)	136dB continuous
NOMINAL IMPEDANCE	8 ohms
DISPERSION (-6dB)	Omnidirectional
CROSSOVER	80-120Hz active
ENCLOSURE	Multi-laminate birch plywood
FINISH	Textured PU coating
PROTECTIVE GRILLE	Perforated steel
CONNECTORS	2 x NL4
PIN CONNECTIONS (INPUT)	+1, -1 (+2, -2 link through)
PIN CONNECTIONS (LINK)	+1, -1 (+2, -2 link through)
FITTINGS	Two skids on base, matching channels on top M20 top-mounted thread plate for pole mounting Integral flyware for suspension of up to four SXF115 Large bar handle on each side Two front-mounting latch plates for wheelboard
DIMENSIONS (INCL FEET)	(W) 500mm x (H) 510mm x (D) 575mm (725mm incl wheelboard) (W) 19.7in x (H) 20.1in x (D) 22.6in (28.5in incl wheelboard)
WEIGHT	45kg (99lbs) 52kg (115lbs) incl wheelboard

Notes

- (1) Measured on-axis in half (2pi) space at 2 metres, then referred to 1 metre.
- (2) AES Standard ANSI S4.26-1984.
- (3) Measured in half (2pi) space at 2 metres with 1 watt input, using band limited pink noise, then referred to 1 metre.
- (4) Measured in half (2pi) space at 2 metres using band limited pink noise, then referred to 1 metre.
- (5) Measured on-axis in open (4pi) space at 2 metres, then referred to 1 metre.
- (6) Measured in open (4pi) space at 2 metres with 1 watt input, using band limited pink noise, then referred to 1 metre.
- (7) Measured in open (4pi) space at 2 metres using band limited pink noise, then referred to 1 metre.
- (8) Measured in open (4pi) space at 2 metres with 2.83V input, using band limited pink noise, then referred to 1 metre.
- (9) Calculated at 1 metre.
- (10) Measured in half (2pi) space at 2 metres with 2.83V input, using band limited pink noise, then referred to 1 metre.

Technical Drawing

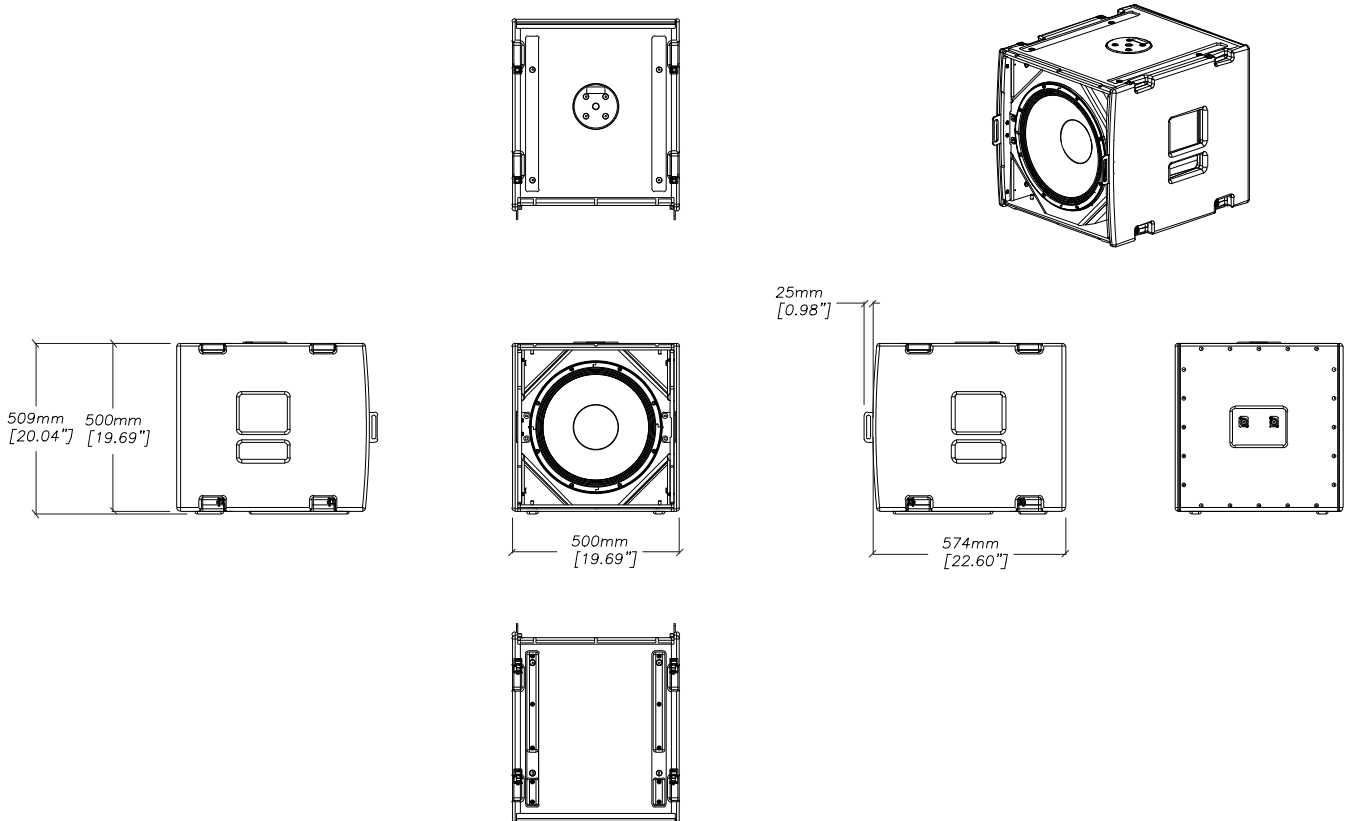

SXC115



Introduction

Designed for touring sound and installations, the SXC115 is a compact, high performance cardioid subwoofer. It features a 15" (380mm) forward facing driver and a 12" (300mm) rear facing driver, each driven independently by separate amplifier channels and DSP. Each driver has its own chamber with optimised bass reflex porting. This arrangement produces a cardioid dispersion pattern which maximises the front radiation and reduces unwanted radiation behind the subwoofer.

The SXC115 produces a cardioid dispersion pattern which maximises the front radiation and reduces unwanted radiation behind the subwoofer. The recommended iKON iK42 amplifier optimises the DSP parameters for front and rear drivers to maximise the rear rejection — from 21dB at 43Hz to 28dB at 75Hz. This keeps low frequencies away from stages, turntables and walls as well as reducing reverberant energy in the room — greatly improving the low frequency response accuracy and impact of the whole system. In front of the enclosure, the output from the two drivers is additive, giving an extra 2dB of output when compared with a conventional 1 x 15" subwoofer.

The SXC115 is an ideal partner for WPM line arrays or Martin Audio point source systems where low frequency pattern control is required. It can be used singly, stacked or flown individually by means of threaded flying inserts.

The enclosure is constructed from birch ply and finished with a hard-wearing textured paint. It is equipped with four grab handles and foam-backed perforated steel grilles protect the front and rear drivers. Interlocking skids prevent movement when stacked and a threaded plate in the top surface facilitates pole-mounting of up to 4 WPM enclosures or a single point source loudspeaker.

The addition of the input cover accessory makes the SXC115 weather resistant and suitable for outdoor usage.

Accessories

M10 eyebolts	HTKCT06
Castor kit	WHEELKIT
Wind-up pole	ASF20071

Connections



The SXC115 features two drivers, a 15" front facing driver and the rear-facing 12" driver used to achieve a cardioid response. Connection is made via two NL4 connectors which are wired in parallel. Although these are nominally labelled 'INPUT' and 'LINK', either connector can be used to connect to the sub or to link out to a second speaker. The Front 15" driver is connected to pins 1+/-, the rear 12" driver to pins 2+/- . A 4-core NL4 cable must be used. If using the recommended iK42 amplifier, connection can be made to output NL4 1 or 3 as these also carry the output signal from channels 2 and 4 respectively to power both drivers.

Flying SXC115

Eyebolts

The SXC115 features M10 inserts to allow flown applications using eyebolts. M10 eyebolts suitable for flown systems are available as accessories from Martin Audio. These are cast steel shouldered eye bolts specifically designed and rated for flown applications. If alternative eyebolts are used these must be cast or machined products stamped with their SWL. Formed steel non-shouldered eyebolts commonly available from DIY stores should not be used under any circumstances as they are not sufficiently load-rated for flown applications. available from DIY stores should not be used under any circumstances as they are not sufficiently load-rated for flown applications.

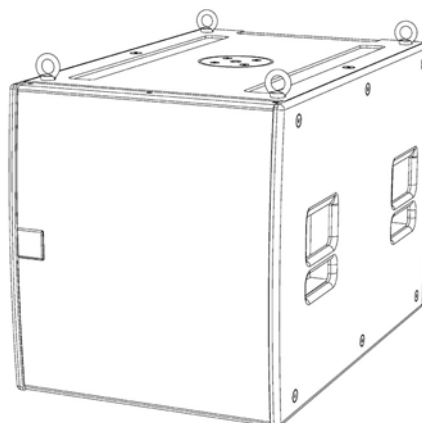

Remove the M10 counter-sunk screws and screw the eyebolts into position. We would recommend four eyebolts and an additional eyebolt as a redundant safety bond. This should be attached to a different point than the other bolts to support the cabinet in the event of the other points failing.

Eyebolts should be connected to a suitably rated fixing point such as a girder clamp or a heavy duty fixing such as a sleeve anchor or similar. They can be linked using suitably rated steel rope or chain and shackles.

Safety note: Flying heavy equipment in public spaces is dangerous and should only be undertaken by suitably qualified and experienced personnel using adequately rated equipment for the task.

Castors

To fit the castors, remove the M8 counter-sunk screws from the rear of the enclosure.

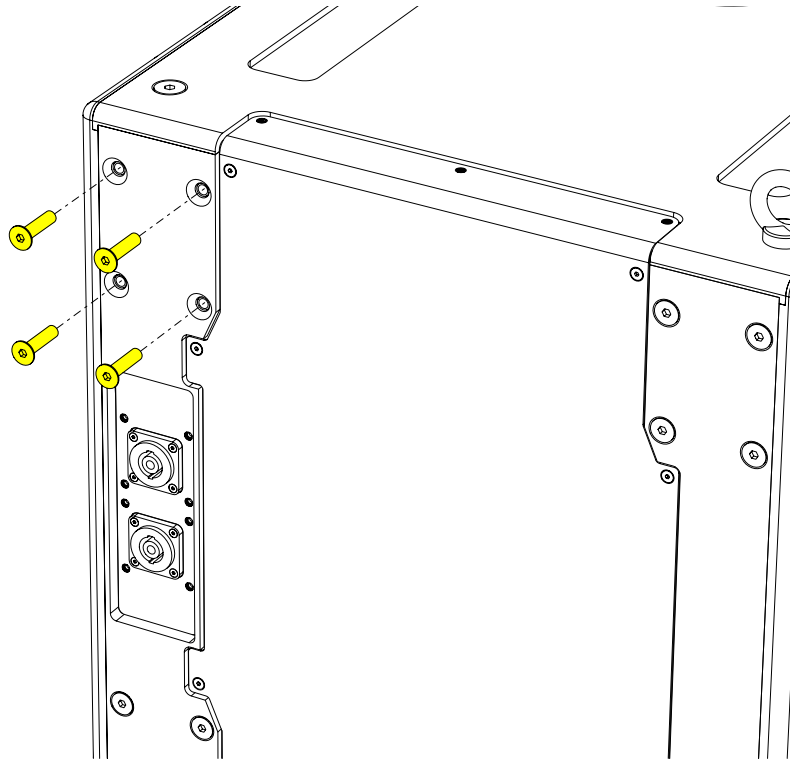

Position each castor over the insets and screw into place using the fixings supplied in the kit.

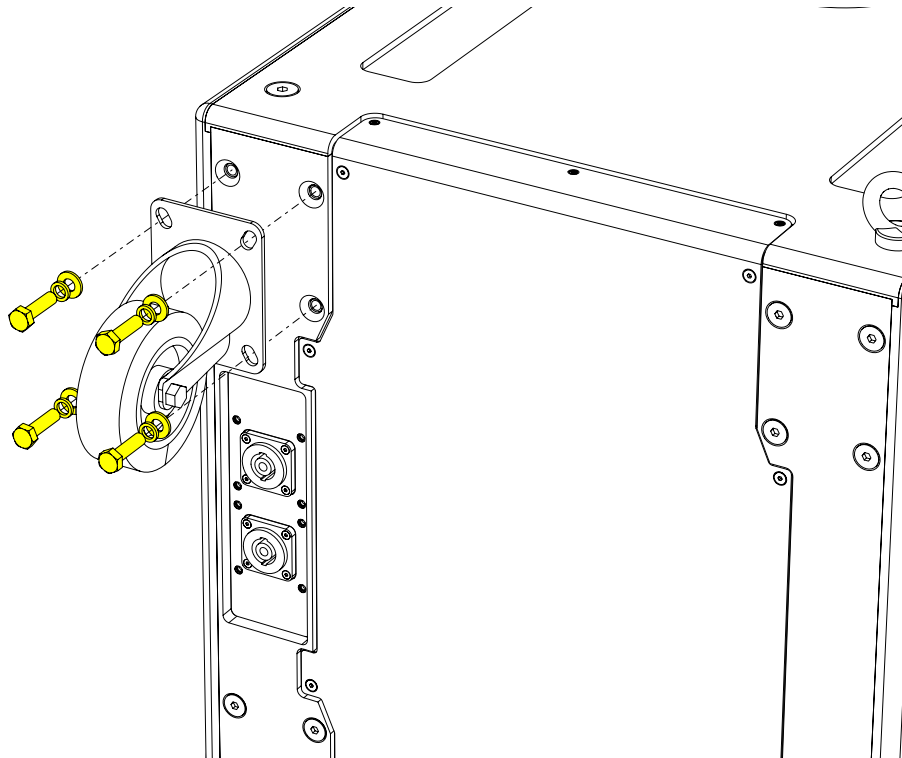

Specifications

TYPE	Compact, cardioid subwoofer
FREQUENCY RESPONSE (1)	44Hz-150Hz ± 3dB, -10dB @ 36Hz
DRIVER	1 x 15" (380mm)/4" (100mm) voice coil, long excursion, ferrite magnet, waterproof cone 1 x 12" (300mm)/4" (88mm) voice coil, long excursion, neodymium magnet, waterproof cone
RATED POWER (2)	15": 1000W AES, 4000W peak. 12": 800W AES, 3200W peak
RECOMMENDED AMPLIFIER	IKON iK42
SENSITIVITY (10)	101dB
MAXIMUM SPL (9)	137dB continuous
NOMINAL IMPEDANCE	15": 8 ohms, 12": 8 ohms
DISPERSION	Cardioid
ENCLOSURE	Multi-laminate birch/poplar plywood
FINISH	Textured black paint
PROTECTIVE GRILLE	Black HEX perforated steel
CONNECTORS	2 x NL4
PIN CONNECTIONS (INPUT)	15" +1, -1 12": +2, -2
PIN CONNECTIONS (LINK)	15" +1, -1 12": +2, -2
FITTINGS	Two skids on base, matching channels on top. 2 x bar handles. M20 top-mounted thread plate for pole mounting 16 x M10 mounting points, 16 x M8 Inserts for optional castors
DIMENSIONS (INCL SKIDS)	(W) 500mm x (H) 550mm x (D) 811mm (939mm including castors)
WEIGHT	53kg (117lbs). 56kg (124lbs) including castors

Notes

- (1) Measured on-axis in half (2pi) space at 2 metres, then referred to 1 metre.
- (2) AES Standard ANSI S4.26-1984.
- (3) Measured in half (2pi) space at 2 metres with 1 watt input, using band limited pink noise, then referred to 1 metre.
- (4) Measured in half (2pi) space at 2 metres using band limited pink noise, then referred to 1 metre.
- (5) Measured on-axis in open (4pi) space at 2 metres, then referred to 1 metre.
- (6) Measured in open (4pi) space at 2 metres with 1 watt input, using band limited pink noise, then referred to 1 metre.
- (7) Measured in open (4pi) space at 2 metres using band limited pink noise, then referred to 1 metre.
- (8) Measured in open (4pi) space at 2 metres with 2.83V input, using band limited pink noise, then referred to 1 metre.
- (9) Calculated at 1 metre.
- (10) Measured in half (2pi) space at 2 metres with 2.83V input, using band limited pink noise, then referred to 1 metre.

Technical Drawing

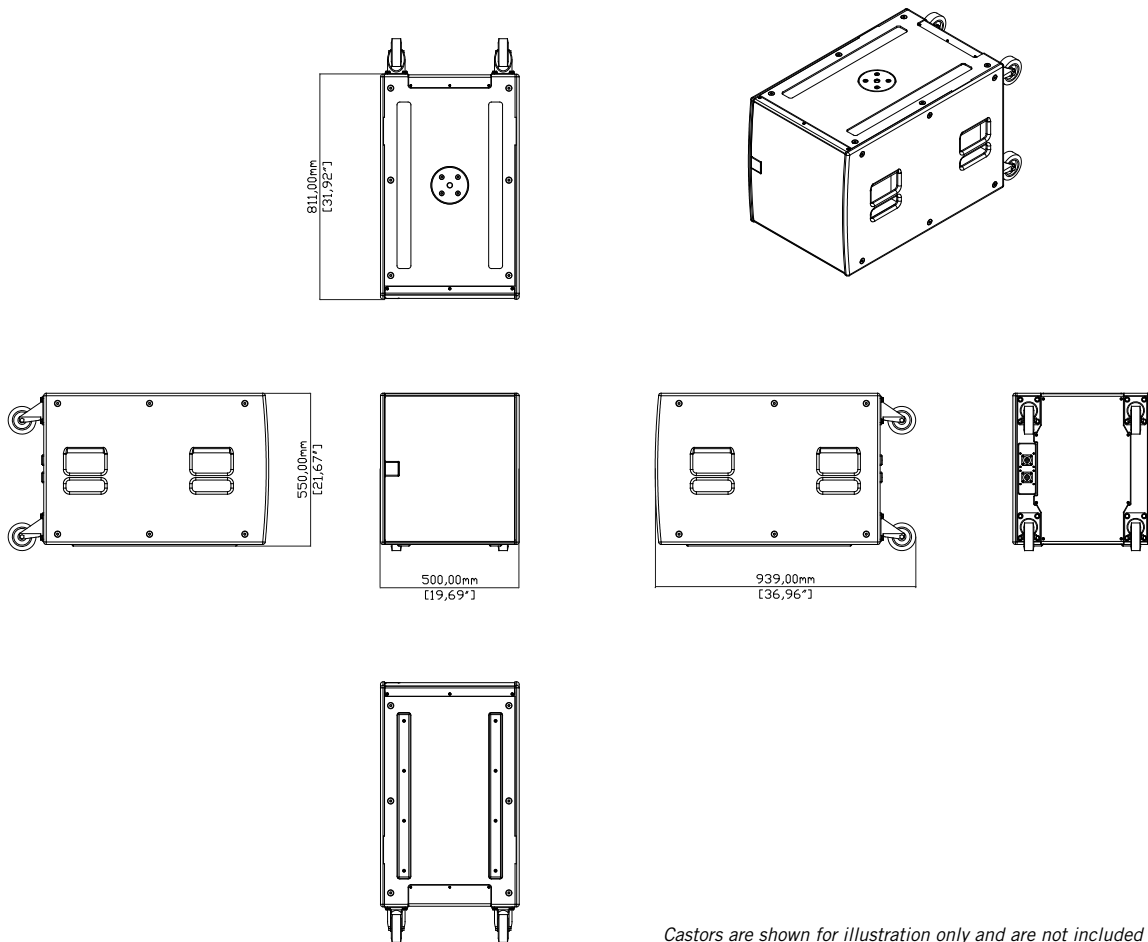

Castors are shown for illustration only and are not included as standard.

SX118



Introduction

The SX118 is a compact, high performance subwoofer that extends the low frequency operating range of the system to 47Hz and provides exceptional low frequency output for such a compact enclosure.

SX118 features a long-excursion 18" (460mm)/4" (100 mm) voice coil driver with a water-resistant cone and triple roll surround in a compact reflex enclosure.

The design of the 18" driver maximises output while minimising power compression and distortion, and the four reflex ports have a large frontal area to reduce turbulent air noise at very high levels. The enclosure is constructed from multi-laminate birch ply, finished with a durable polyurea coating and equipped with a Zintec grille, twin grab handles, skids, flying inserts for installation and a threaded pole socket for pole-mounting point source loudspeakers or up to 4 WPM enclosures as a simple plug-and-play system.

The product is supplied as standard without cabinet wheels, but they are available as an accessory.

By adding the input board cover accessory, SX118 is fully weather resistant and suitable for permanent outdoor usage.

Accessories

M10 eyebolts	HTKCT06
Transit cover	CDDLTC118
Castor kit	WHEELKIT
Wind-up pole	ASF20071
Weather kit	WRKIT

Connections



The SX118 has a pair of NL4 connectors on the rear panel. These are wired in parallel and whilst one is nominally labelled 'INPUT' and the other as 'LINK', connection in and out can be made to either connector. Connection to the drive unit(s) is made to pins 1+/- . There is no internal connection to pins 2+/- although these are linked together so can be used for example to carry a mid/top signal and connected to a full range system using a cable wired with reverse connections (pins 2 to pins 1).

Flying SX118

Eyebolts

The SX118 features M10 inserts to allow flown applications using eyebolts. M10 eyebolts suitable for flown systems are available as accessories from Martin Audio. These are cast steel shouldered eye bolts specifically designed and rated for flown applications. If alternative eyebolts are used these must be cast or machined products stamped with their SWL. Formed steel non-shouldered eyebolts commonly available from DIY stores should not be used under any circumstances as they are not sufficiently load-rated for flown applications.

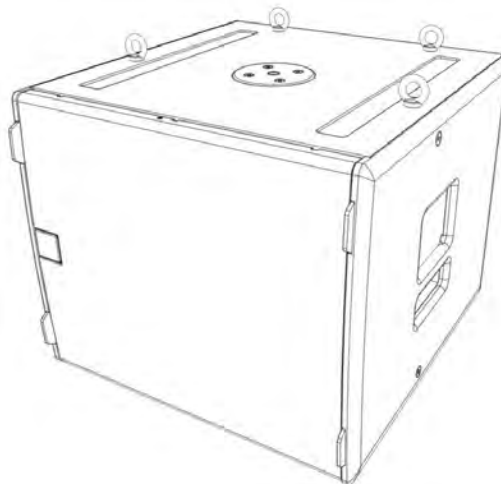

Remove the M10 counter-sunk screws and screw the eyebolts into position. We would recommend four eyebolts and an additional eyebolt as a redundant safety bond. This should be attached to a different point than the other bolts to support the cabinet in the event of the other points failing.

Eyebolts should be connected to a suitably rated fixing point such as a girder clamp or a heavy duty fixing such as a sleeve anchor or similar. They can be linked using suitably rated steel rope or chain and shackles.

Safety note: Flying heavy equipment in public spaces is dangerous and should only be undertaken by suitably qualified and experienced personnel using adequately rated equipment for the task.

Transit Covers

The SX118 features an optional transit cover to protect the cabinet when used in portable applications.

To ensure that the insert is accurately located, four locating brackets are utilised. These are built into the cabinet in the four corners and may be fitted in the parked position as standard. To use with the transit cover it is necessary to reverse the four brackets.

Remove the top and bottom safety screws from the grille. Insert a flat blade screwdriver into the slots of the grille and carefully easing the grille out of the slot.

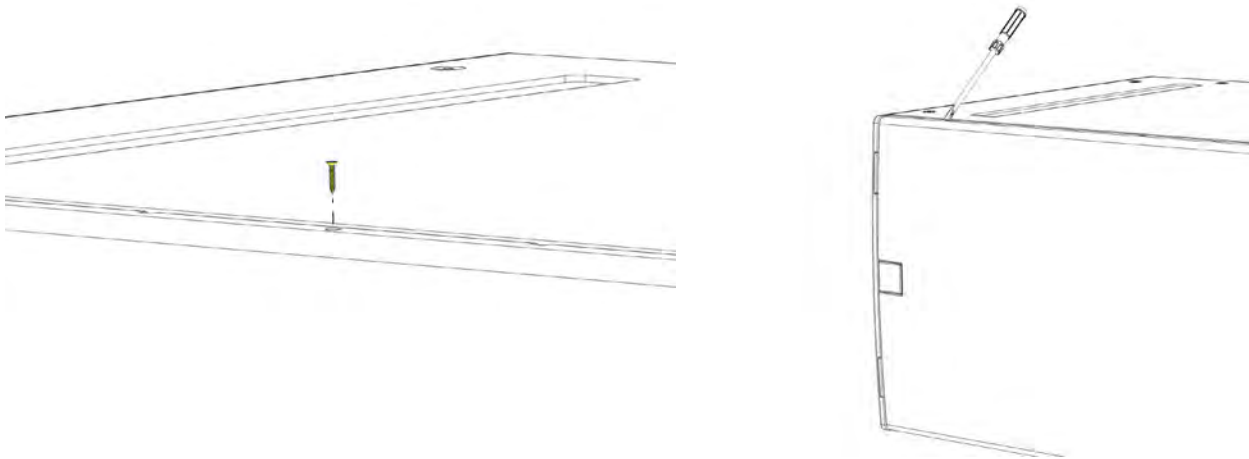

Remove the screws from the grille support on the side of the cabinet and remove the grille support.

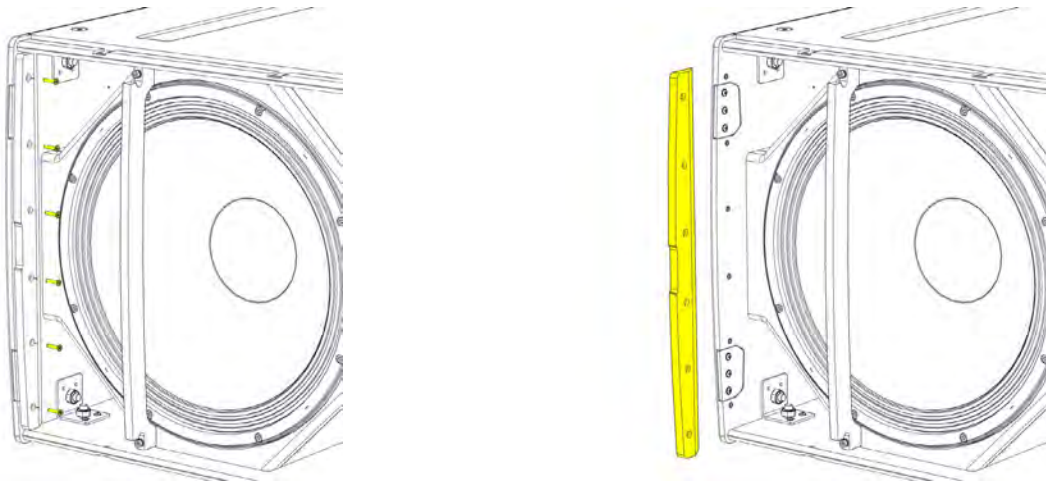

Remove the three screws from the bracket.

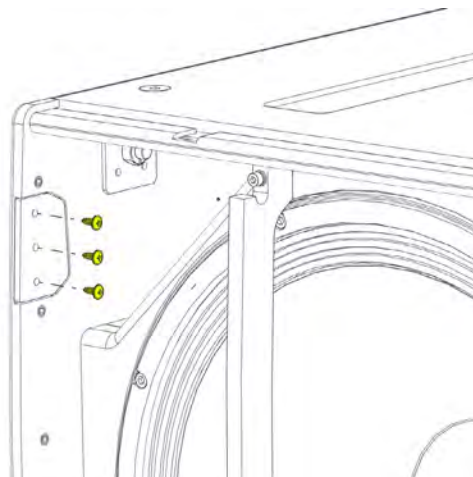

Rotate the bracket 180°. The bracket will now extend approximately 20mm from the front edge of the cabinet, ensure that the slope on the bracket follows the curved contour of the cabinet.

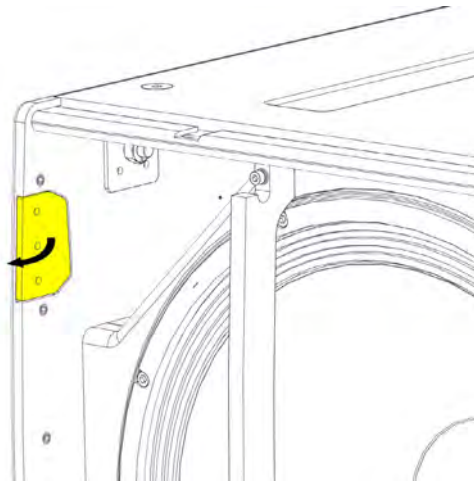

Screw the bracket back in place and repeat for the other three brackets.

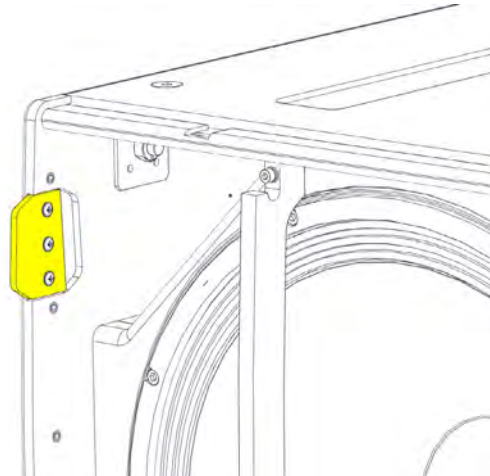
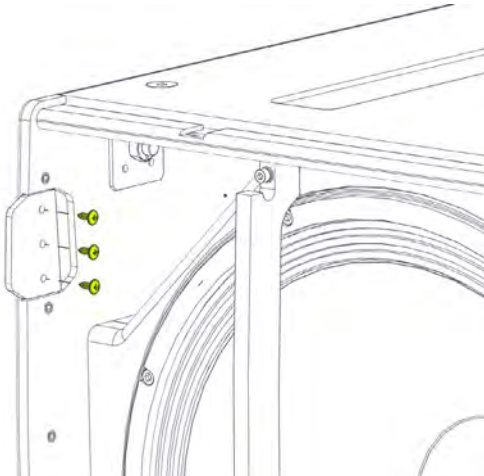

Replace the grill supports and fit the grille making sure the safety screws are used.

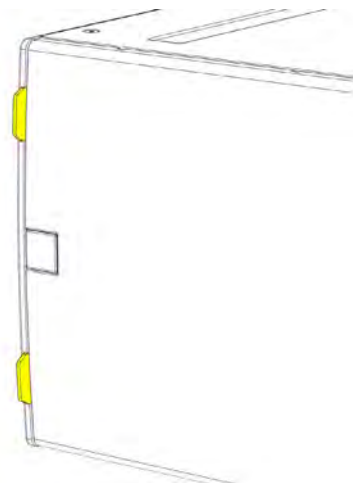
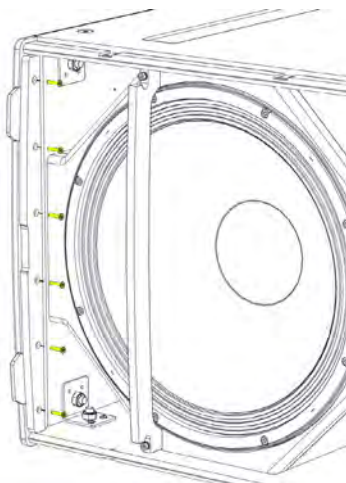

Castors

To fit the castors, remove the M8 counter-sunk screws from the rear of the enclosure.

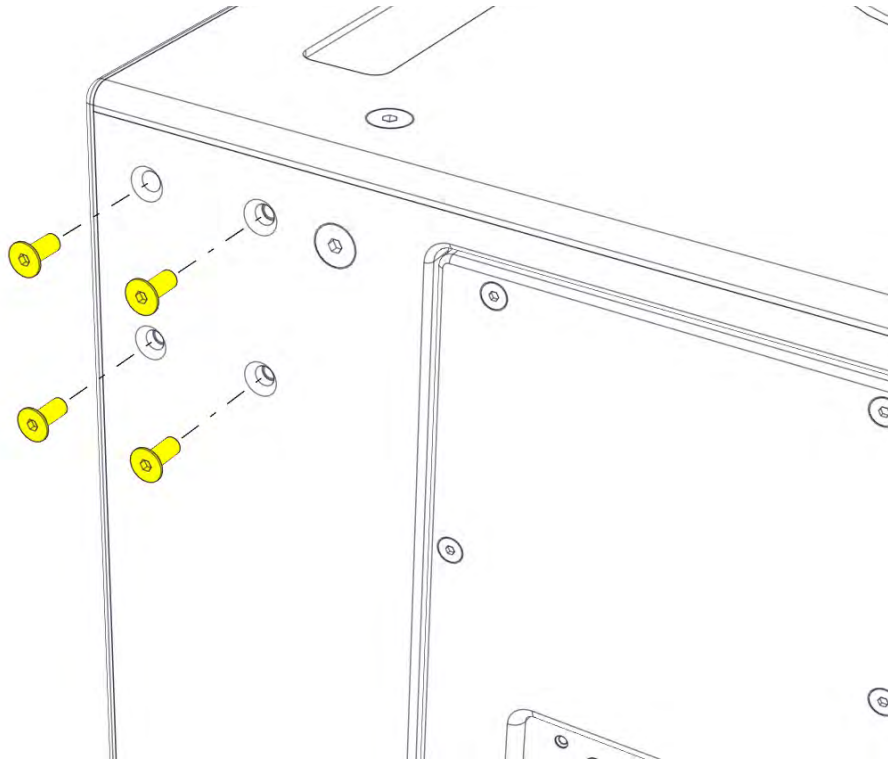

Position each castor over the insets and screw into place using the fixings supplied in the kit.

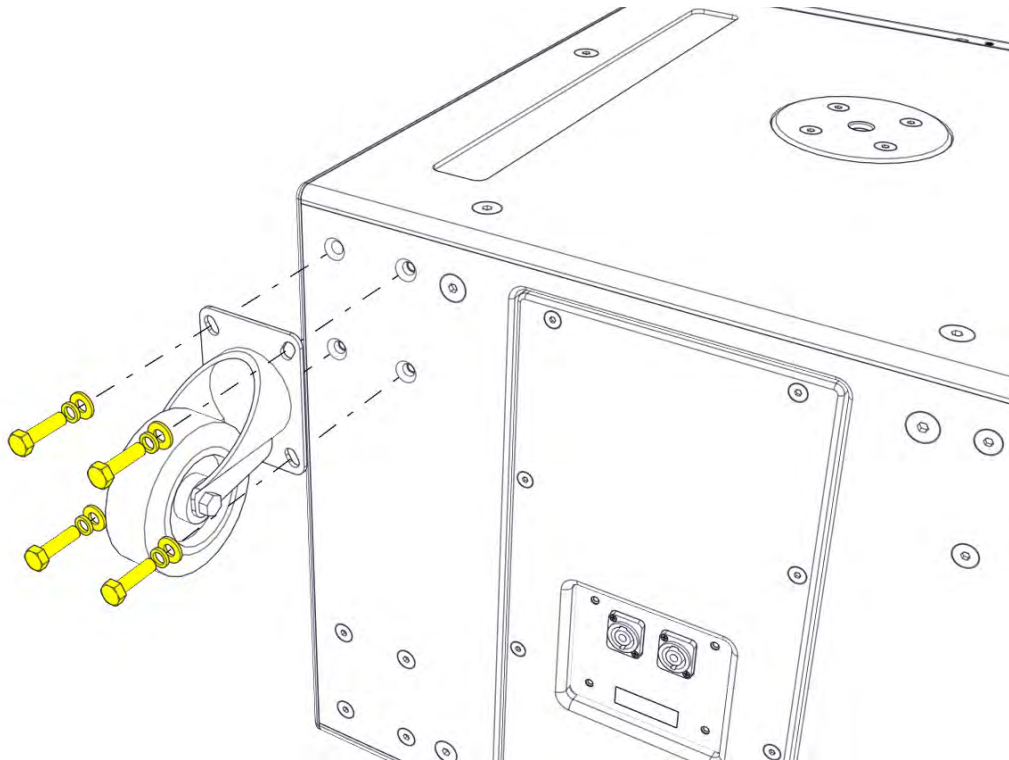

Weather Kit

The WRKIT for non-powered SX Series subwoofers is a glanded cover which fits over the connection panel to prevent water ingress protecting the NL4 speaker connection.

The cable entry may be through one of two knock-out positions depending the angle from which you wish the cable to enter. First remove the knock-out blank that you wish to use and fit the cable gland in position. Note that to use the WRKIT it is necessary to remove the NL4 connector from your speaker cable so the cable can be fed through the cable gland. Once the cable has been threaded through the gland the NL4 can be re-attached.

Remove the four counter-sunk screws in the connector panel and position the cover on the connector panel. Connect the NL4 to the input connector and position the cover, pulling the slack in the speaker cable as you lower the cover in position. Secure the cover using the four M4 x 25 cap socket screws and fibre washers. Finally tighten the gland to ensure a waterproof seal.

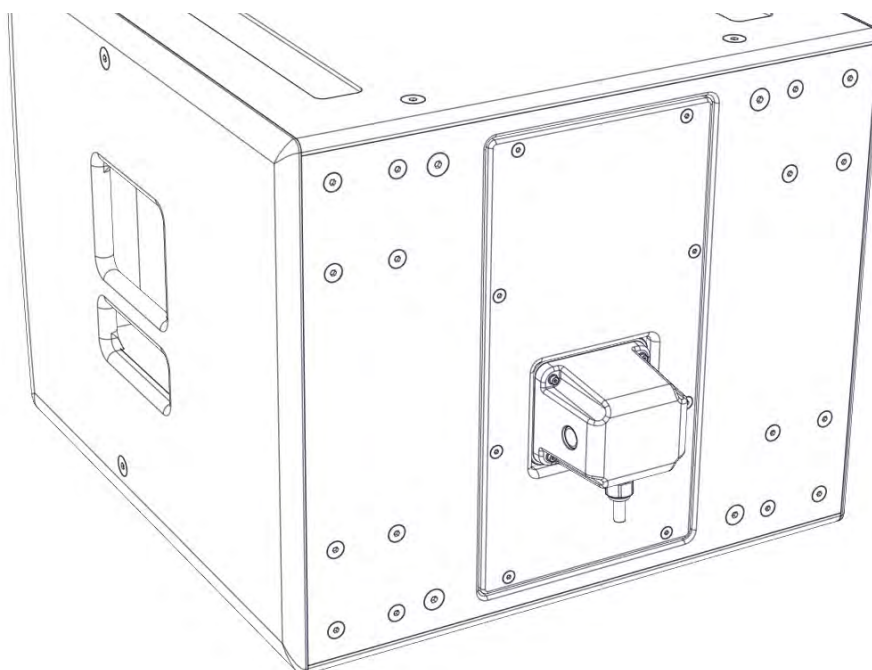
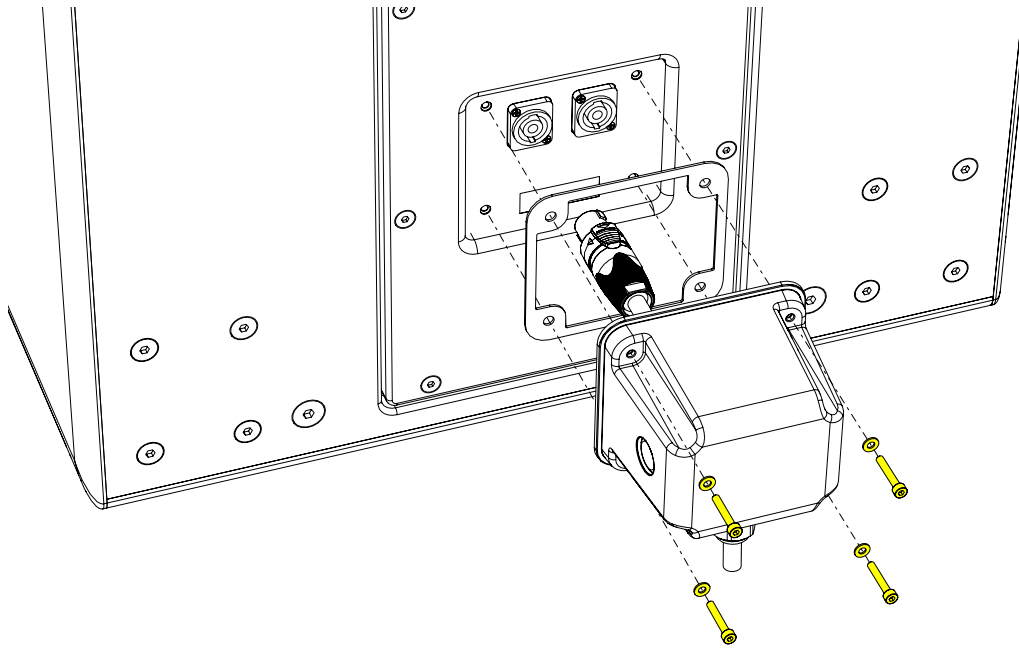

Specifications

TYPE	Compact, direct radiating subwoofer
FREQUENCY RESPONSE (1)	47Hz-150Hz \pm 3dB, -10dB @ 41Hz
DRIVER	1 x 18" (460mm)/4" (100mm) voice coil, long excursion, ferrite magnet, waterproof cone
RATED POWER (2)	1000W AES, 4000W peak
RECOMMENDED AMPLIFIER	iK42/81
SENSITIVITY (10)	102dB
MAXIMUM SPL (9)	138dB continuous
NOMINAL IMPEDANCE	8 ohms
DISPERSION (-6dB)	Omnidirectional
CROSSOVER	80-120Hz active
ENCLOSURE	Multi-laminate birch/poplar plywood
FINISH	Textured black paint
PROTECTIVE GRILLE	Perforated steel
CONNECTORS	2 x NL4
PIN CONNECTIONS (INPUT)	+1, -1 (+2, -2 link through)
PIN CONNECTIONS (LINK)	+1, -1 (+2, -2 link through)
FITTINGS	Two skids on base, with mating channels on top Four rear-mounted 100mm (4in) castors M20 top-mounted thread plate for pole mounting 16 x M10 mounting points 2 x bar handles, 1 on each side 4 x fittings for optional transit cover
DIMENSIONS (INCL FEET)	(W) 600mm x (H) 509mm x (D) 632mm (760mm including castors) (W) 23.62in x (H) 20.04in x (D) 24.86in (29.9in including castors)
WEIGHT	47kg (104lbs)

Notes

- (1) Measured on-axis in half (2pi) space at 2 metres, then referred to 1 metre.
- (2) AES Standard ANSI S4.26-1984.
- (3) Measured in half (2pi) space at 2 metres with 1 watt input, using band limited pink noise, then referred to 1 metre.
- (4) Measured in half (2pi) space at 2 metres using band limited pink noise, then referred to 1 metre.
- (5) Measured on-axis in open (4pi) space at 2 metres, then referred to 1 metre.
- (6) Measured in open (4pi) space at 2 metres with 1 watt input, using band limited pink noise, then referred to 1 metre.
- (7) Measured in open (4pi) space at 2 metres using band limited pink noise, then referred to 1 metre.
- (8) Measured in open (4pi) space at 2 metres with 2.83V input, using band limited pink noise, then referred to 1 metre.
- (9) Calculated at 1 metre.
- (10) Measured in half (2pi) space at 2 metres with 2.83V input, using band limited pink noise, then referred to 1 metre.

Technical Drawing

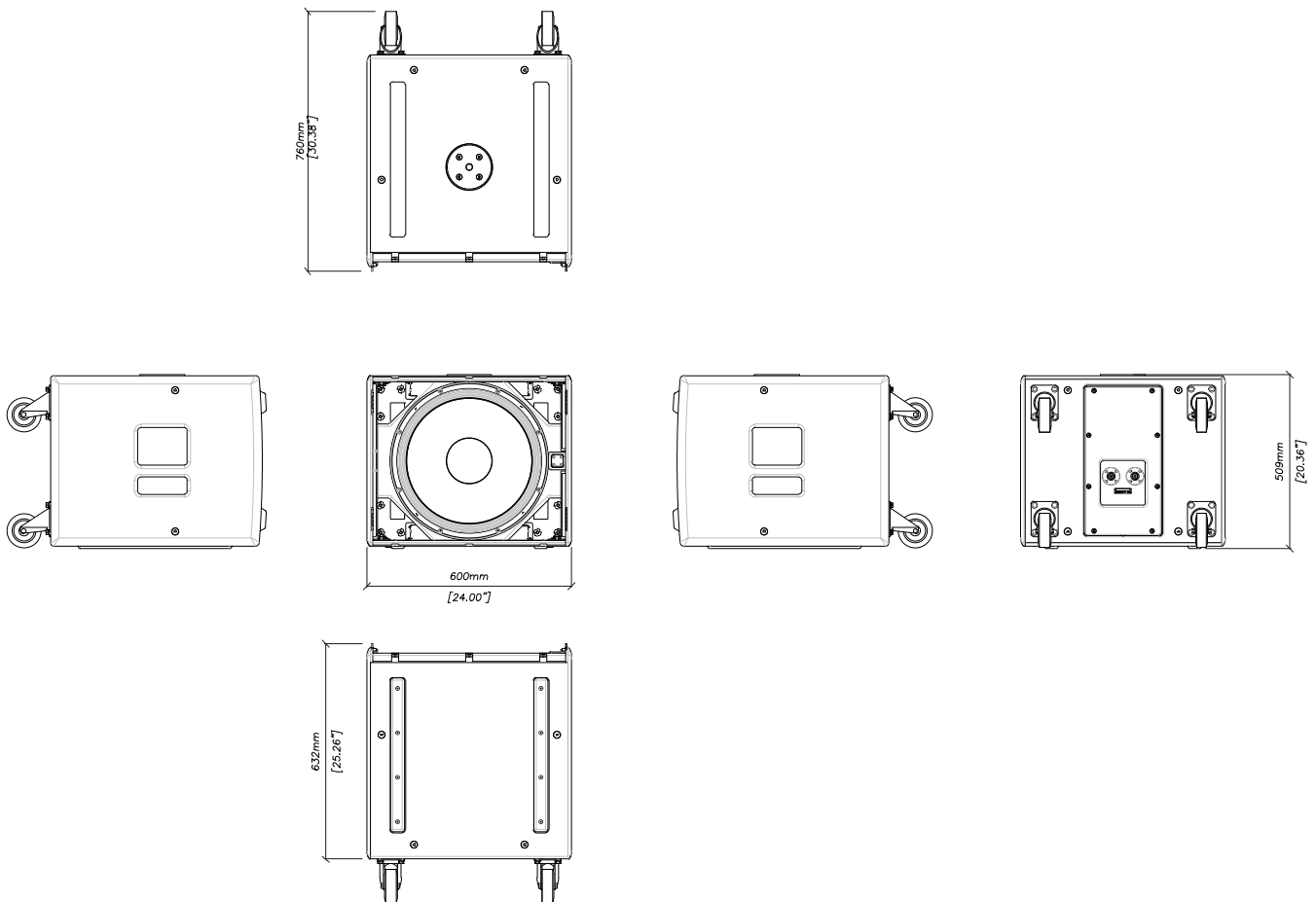

Castors are shown for illustration only and are not included as standard.

SXC118



Introduction

Designed for touring sound and installations, the SXC118 is a compact, high performance cardioid subwoofer. It features an 18" (460mm) forward facing driver and a 14" (356mm) rear facing driver, each driven independently by separate amplifier channels and DSP. Each driver has its own chamber with optimised bass reflex porting.

This arrangement produces a cardioid dispersion pattern which maximises the front radiation and reduces unwanted radiation behind the subwoofer.

The recommended iK42 amplifier optimises the DSP parameters for front and rear drivers to maximise the rear rejection — from 21dB at 43Hz to 28dB at 75Hz. This keeps low frequencies away from stages, turntables and walls as well as reducing reverberant energy in the room, greatly improving the system's low frequency response accuracy and impact.

In front of the enclosure, the output from the two drivers is additive, giving an extra 2dB of output when compared with a conventional 1 x 18" subwoofer.

Accessories

M10 eyebolts	HTKCT06
Transit cover	SXC118TC
Castor kit	WHEELKIT
Wind-up pole	ASF20071
Weather kit	WRKIT

Connections



The SXC118 features two drivers, an 18” front facing driver and the rear-facing 14” driver used to achieve a cardioid response. Connection is made via two NL4 connectors which are wired in parallel. Although these are nominally labelled ‘INPUT’ and ‘LINK’, either connector can be used to connect to the sub or to link out to a second speaker. The Front 18” driver is connected to pins 1+/-, the rear 14” driver to pins 2+/- . A 4-core NL4 cable must be used. If using the recommended iK42 amplifier, connection can be made to output NL4 1 or 3 as these also carry the output signal from channels 2 and 4 respectively to power both drivers.

Flying SXC118

Eyebolts

The SXC118 features M10 inserts to allow flown applications using eyebolts. M10 eyebolts suitable for flown systems are available as accessories from Martin Audio. These are cast steel shouldered eye bolts specifically designed and rated for flown applications. If alternative eyebolts are used these must be cast or machined products stamped with their SWL. Formed steel non-shouldered eyebolts commonly available from DIY stores should not be used under any circumstances as they are not sufficiently load-rated for flown applications.

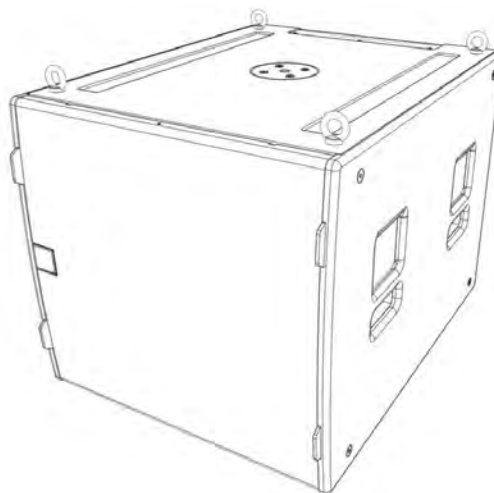

Remove the M10 counter-sunk screws and screw the eyebolts into position. We would recommend four eyebolts and an additional eyebolt as a redundant safety bond. This should be attached to a different point than the other bolts to support the cabinet in the event of the other points failing.

Eyebolts should be connected to a suitably rated fixing point such as a girder clamp or a heavy duty fixing such as a sleeve anchor or similar. They can be linked using suitably rated steel rope or chain and shackles.

Safety note: Flying heavy equipment in public spaces is dangerous and should only be undertaken by suitably qualified and experienced personnel using adequately rated equipment for the task.

Transit Covers

The SXC118 features an optional transit cover to protect the cabinet when used in portable applications.

To ensure that the insert is accurately located, four locating brackets are utilised. These are built into the cabinet in the four corners and may be fitted in the parked position as standard. To use with the transit cover it is necessary to reverse the four brackets.

Remove the top and bottom safety screws from the grille. Insert a flat blade screwdriver into the slots of the grille and carefully easing the grille out of the slot.

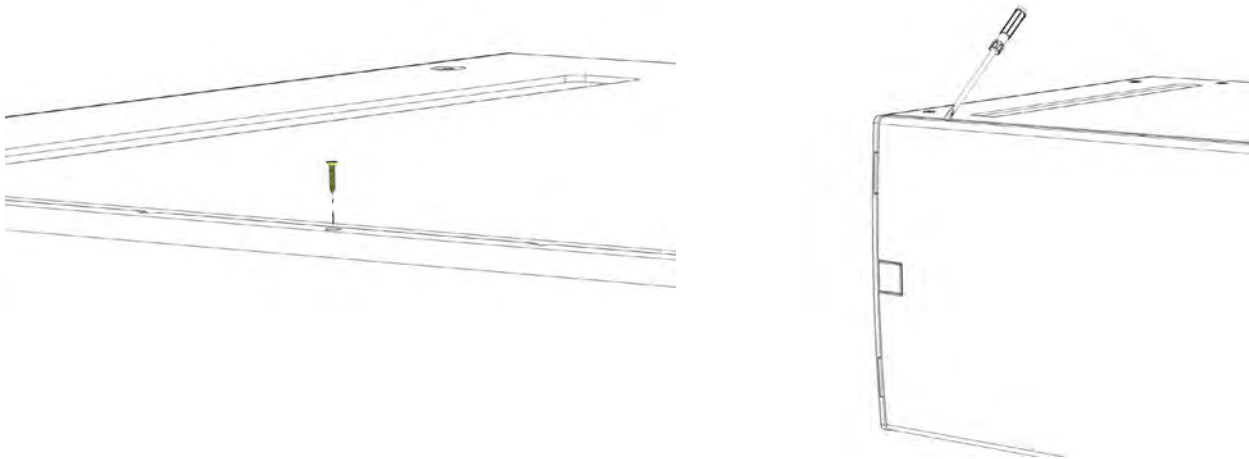

Remove the screws from the grille support on the side of the cabinet and remove the grille support.

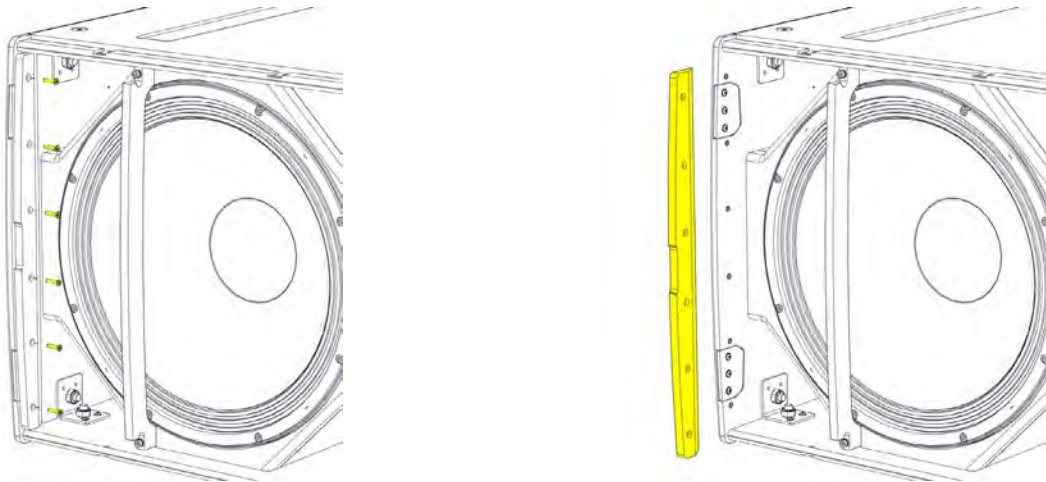

Remove the three screws from the bracket.

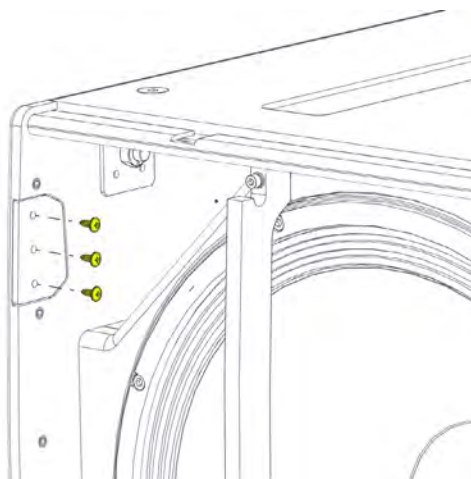

Rotate the bracket 180°. The bracket will now extend approximately 20mm from the front edge of the cabinet, ensure that the slope on the bracket follows the curved contour of the cabinet.

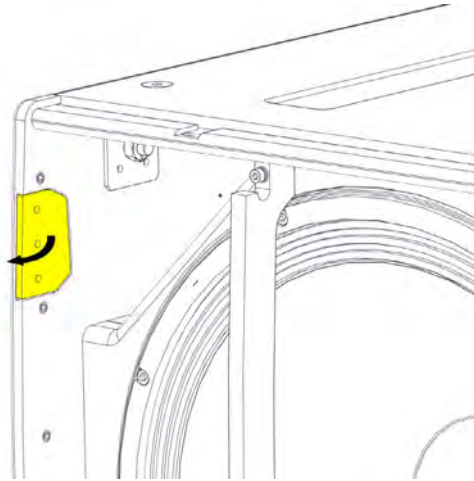

Screw the bracket back in place and repeat for the other three brackets.

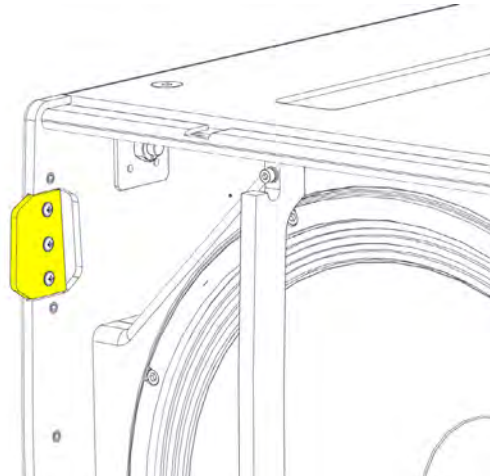
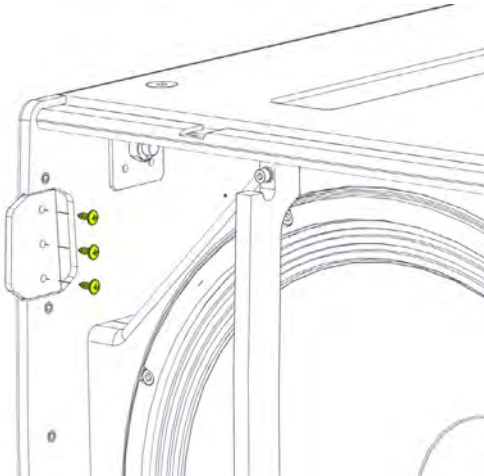

Replace the grill supports and fit the grille making sure the safety screws are used.\

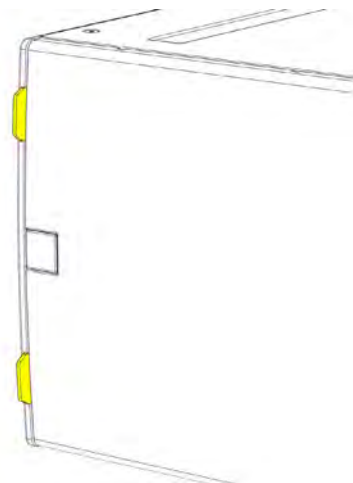
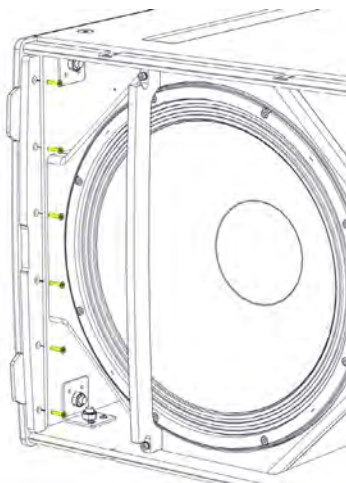

Castors

To fit the castors, remove the M8 counter-sunk screws from the rear of the enclosure.

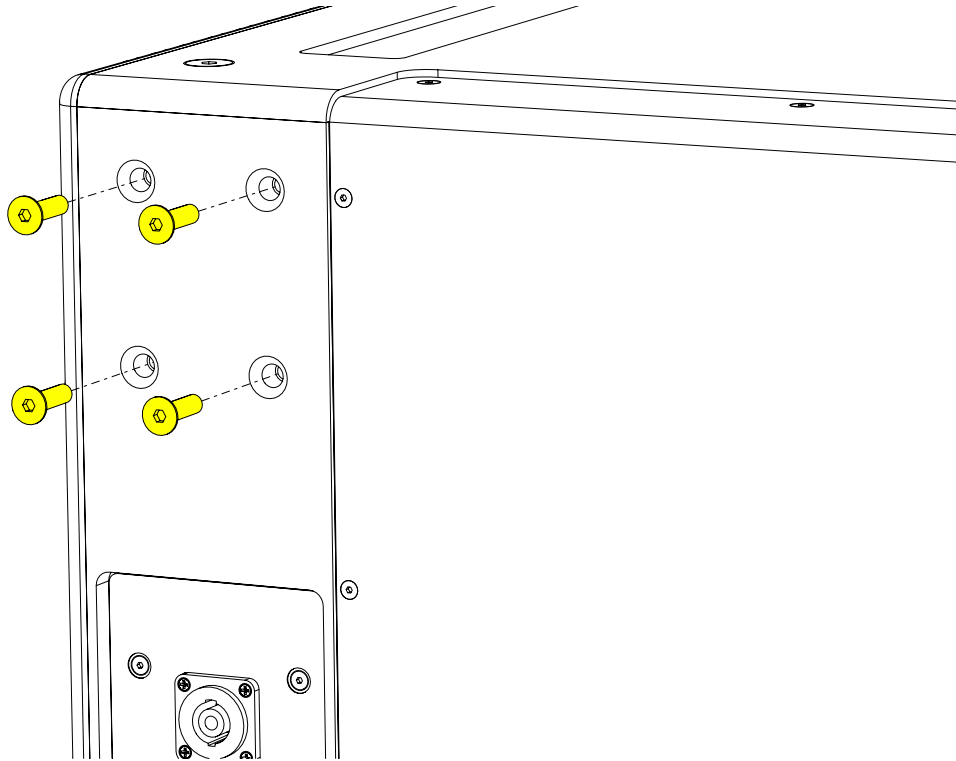

Position each castor over the insets and screw into place using the fixings supplied in the kit.

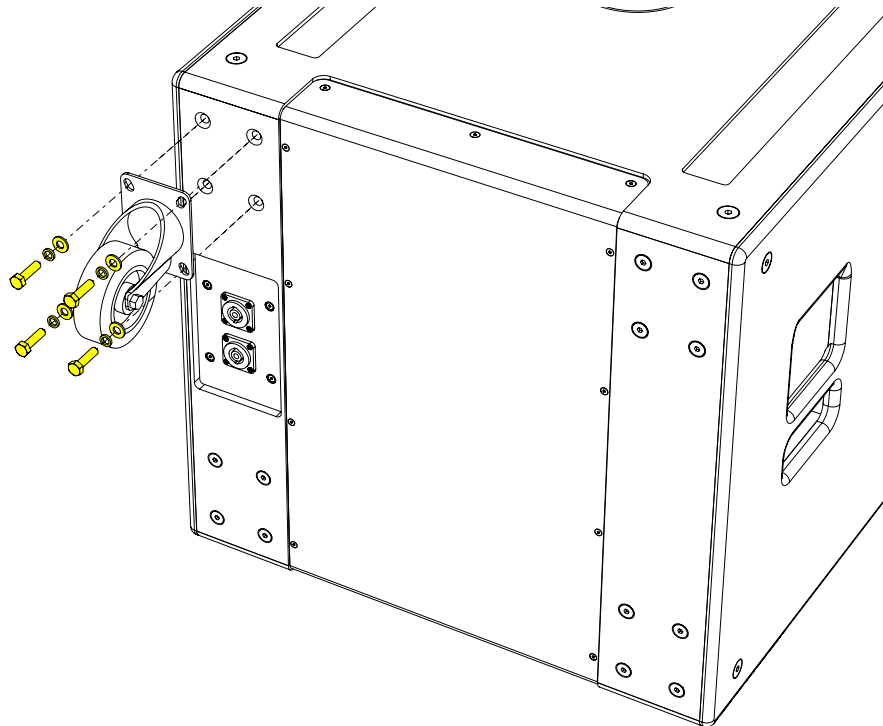

Weather Kit

The WRKIT for non-powered SX Series subwoofers is a glanded cover which fits over the connection panel to prevent water ingress protecting the NL4 speaker connection.

The cable entry may be through one of two knock-out positions depending the angle from which you wish the cable to enter. First remove the knock-out blank that you wish to use and fit the cable gland in position. Note that to use the WRKIT it is necessary to remove the NL4 connector from your speaker cable so the cable can be fed through the cable gland. Once the cable has been threaded through the gland the NL4 can be re-attached.

Remove the four counter-sunk screws in the connector panel and position the cover on the connector panel. Connect the NL4 to the input connector and position the cover, pulling the slack in the speaker cable as you lower the cover in position. Secure the cover using the four M4 x 25 cap socket screws and fibre washers. Finally tighten the gland to ensure a waterproof seal.

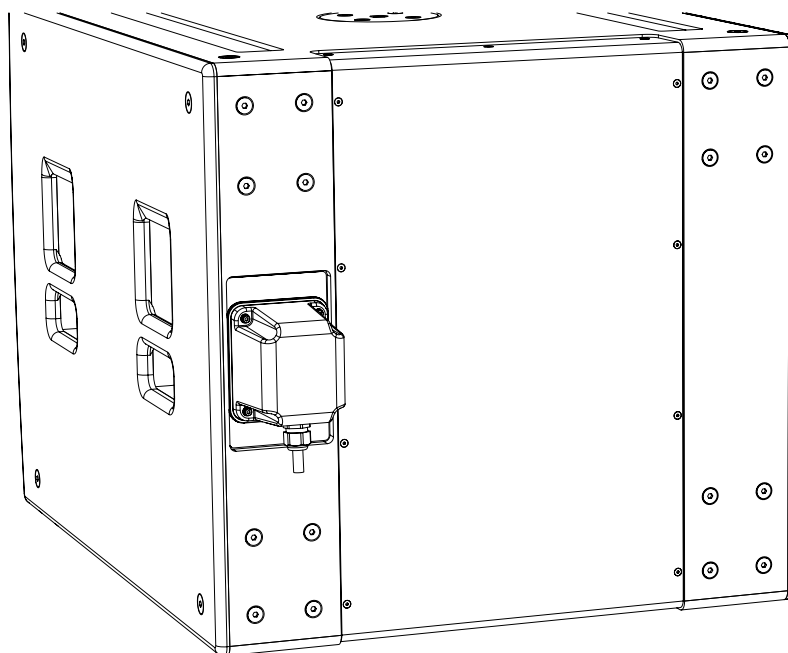
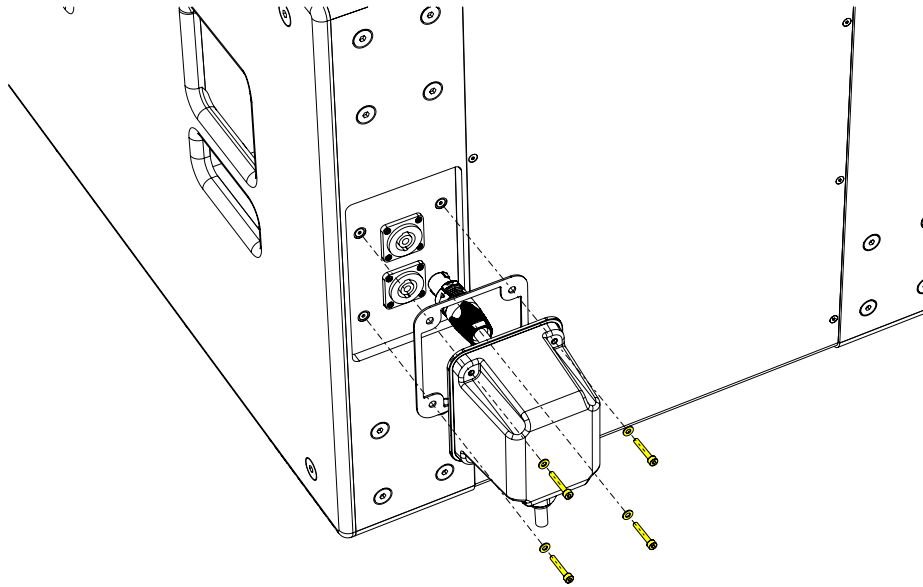

Specifications

TYPE	Compact, cardioid subwoofer
FREQUENCY RESPONSE (1)	43Hz-150Hz ± 3dB, -10dB @ 34Hz
DRIVER	1 x 18" (460mm)/4" (100mm) voice coil, long excursion, ferrite magnet, waterproof cone 1 x 14" (365mm)/3.5" (88mm) voice coil, long excursion, neodymium magnet, waterproof
RATED POWER (2)	18": 1000W AES, 4000W peak. 14": 800W AES, 3200W peak
RECOMMENDED AMPLIFIER	iK42
SENSITIVITY (10)	104dB
MAXIMUM SPL (9)	140dB continuous
NOMINAL IMPEDANCE	18": 8 ohms, 14": 8 ohms
DISPERSION (-6dB)	Cardioid
CROSSOVER	80-120Hz active
ENCLOSURE	Multi-laminate birch/poplar plywood
FINISH	Textured black paint
PROTECTIVE GRILLE	Perforated steel
CONNECTORS	2 x NL4
PIN CONNECTIONS (INPUT)	18" +1, -1 14": +2, -2
PIN CONNECTIONS (LINK)	18" +1, -1 14": +2, -2
FITTINGS	Two skids on base, with mating channels on top M20 top-mounted thread plate for pole mounting Two bar handles on each side Four fittings for optional transit cover 16 x M10 mounting points 16 x M8 inserts for optional castors
DIMENSIONS (INCL FEET)	(W) 635mm x (H) 603mm x (D) 824mm (952mm including castors) (W) 25in x (H) 23.7in x (D) 32.4in (37.5in including castors)
WEIGHT	69kg (152lbs). 73kg (161lbs) including castors 73kg (161lbs) incl castors

Notes

- (1) Measured on-axis in half (2pi) space at 2 metres, then referred to 1 metre.
- (2) AES Standard ANSI S4.26-1984.
- (3) Measured in half (2pi) space at 2 metres with 1 watt input, using band limited pink noise, then referred to 1 metre.
- (4) Measured in half (2pi) space at 2 metres using band limited pink noise, then referred to 1 metre.
- (5) Measured on-axis in open (4pi) space at 2 metres, then referred to 1 metre.
- (6) Measured in open (4pi) space at 2 metres with 1 watt input, using band limited pink noise, then referred to 1 metre.
- (7) Measured in open (4pi) space at 2 metres using band limited pink noise, then referred to 1 metre.
- (8) Measured in open (4pi) space at 2 metres with 2.83V input, using band limited pink noise, then referred to 1 metre.
- (9) Calculated at 1 metre.
- (10) Measured in half (2pi) space at 2 metres with 2.83V input, using band limited pink noise, then referred to 1 metre.

Technical Drawing

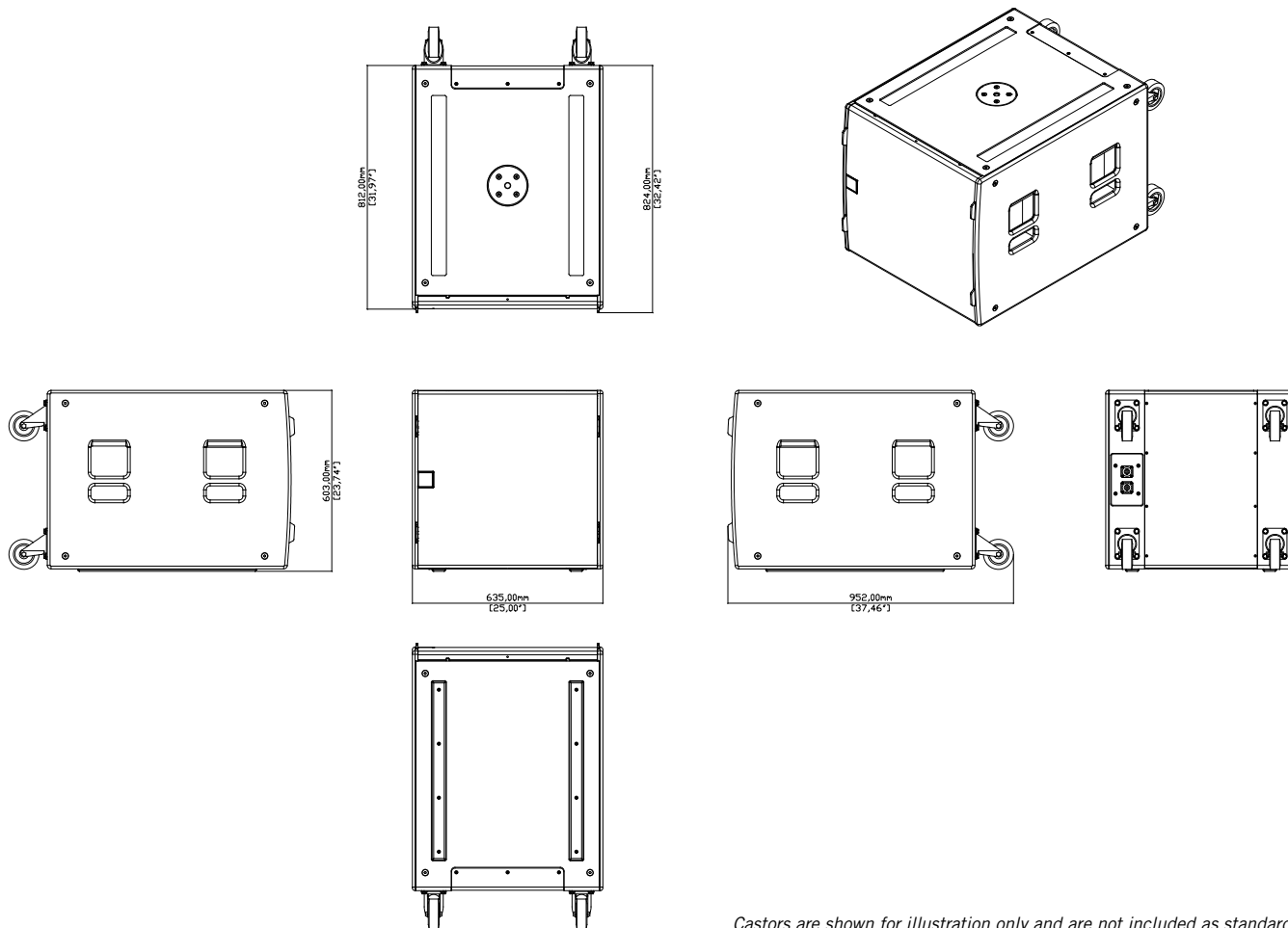

Castors are shown for illustration only and are not included as standard.

SXCF118



Introduction

The SXCF118 is a compact, high performance cardioid subwoofer. The flown version of the SXC118, it is the ideal partner for flown WPS arrays — combining maximum low frequency output with pattern control. It features an 18" (460mm) forward facing driver and a 14" (356mm) rear facing driver, each driven independently by separate amplifier channels and DSP. Each driver has its own chamber with optimised bass reflex porting.

This arrangement produces a cardioid dispersion pattern which maximises the front radiation and reduces unwanted radiation behind the subwoofer.

The recommended iK42 amplifier optimises the DSP parameters for front and rear drivers to maximise the rear rejection — from 21dB at 43Hz to 28dB at 75Hz. This keeps low frequencies away from stages, turntables and walls as well as reducing reverberant energy in the room, greatly improving the system's low frequency response accuracy and impact.

In front of the enclosure, the output from the two drivers is additive, giving an extra 2dB of output when compared with a conventional 1 x 18" subwoofer.

Accessories

M10 eyebolts	HTKCT06
Transit cover	SXC118TC
Castor kit	WHEELKIT
Wind-up pole	ASF20071
Weather kit	WRKIT
Flying frame	WPSGRIDt

Connections



The SXCF118 features two drivers, an 18” front facing driver and the rear-facing 14” driver used to achieve a cardioid response. Connection is made via two NL4 connectors which are wired in parallel. Although these are nominally labelled ‘INPUT’ and ‘LINK’, either connector can be used to connect to the sub or to link out to a second speaker. The Front 18” driver is connected to pins 1+/-, the rear 14” driver to pins 2+/- . A 4-core NL4 cable must be used. If using the recommended iK42 amplifier, connection can be made to output NL4 1 or 3 as these also carry the output signal from channels 2 and 4 respectively to power both drivers.

Flying SXCF118

Eyebolts

The SXCF118 features M10 inserts to allow flown applications using eyebolts. M10 eyebolts suitable for flown systems are available as accessories from Martin Audio. These are cast steel shouldered eye bolts specifically designed and rated for flown applications. If alternative eyebolts are used these must be cast or machined products stamped with their SWL. Formed steel non-shouldered eyebolts commonly available from DIY stores should not be used under any circumstances as they are not sufficiently load-rated for flown applications.

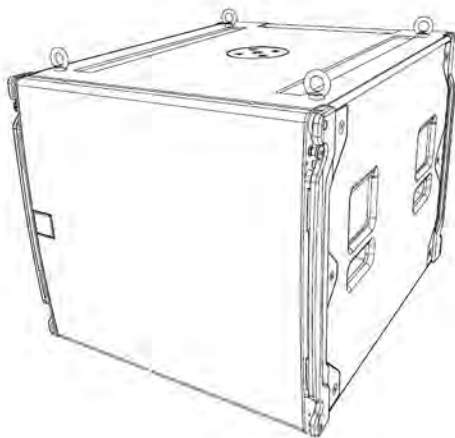

Remove the M10 counter-sunk screws and screw the eyebolts into position. We would recommend four eyebolts and an additional eyebolt as a redundant safety bond. This should be attached to a different point than the other bolts to support the cabinet in the event of the other points failing.

Eyebolts should be connected to a suitably rated fixing point such as a girder clamp or a heavy duty fixing such as a sleeve anchor or similar. They can be linked using suitably rated steel rope or chain and shackles.

Safety note: Flying heavy equipment in public spaces is dangerous and should only be undertaken by suitably qualified and experienced personnel using adequately rated equipment for the task.

WPSGRIDt

Using one or two motors position a WPSGRIDt above the SXCF118 and lower it onto the enclosure.

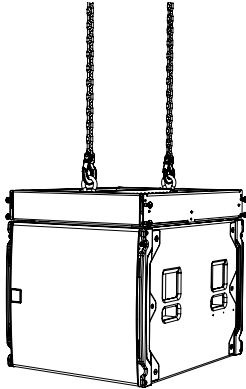

Replace the pins to link and lock the SXCF118 securely to the WPSGRIDt.

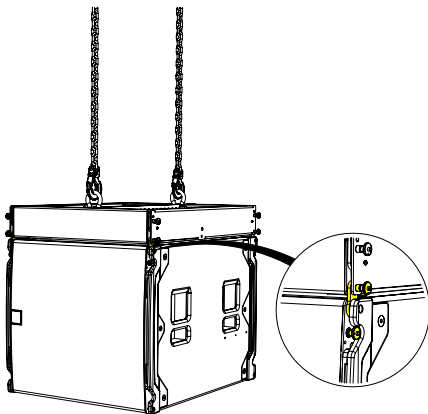

Remove the pins from the stow position, rotate the links to line up with the pin hole position on the SXCF118 above.

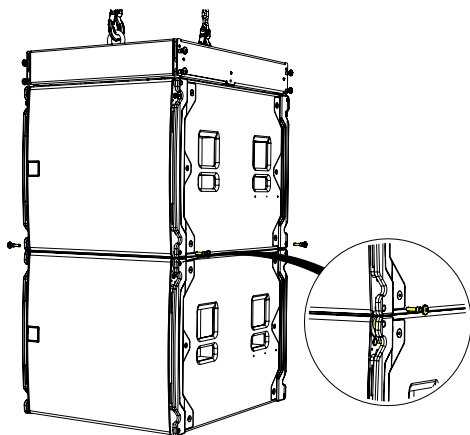

Repeat the procedure for each sub to be included in the array to a maximum of 16 SXCF118. For arrays that consist of SXCF118 and WPS, please refer to the WPS manual.

Remove the pins from the from SXCF118 to release the links. Rotate the SXCF118 links and line them up with the pin holes in the WPSGRIDt.

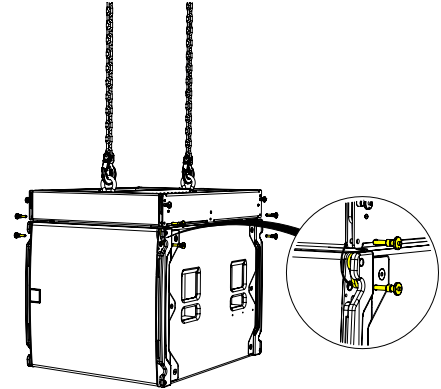

Raise the WPSGRIDt and SXCF118 to a height suitable to fit another SXCF118 below the array, lower it making sure the protective nylon skids line up and fit into the recessed channels on the SXCF118 below.

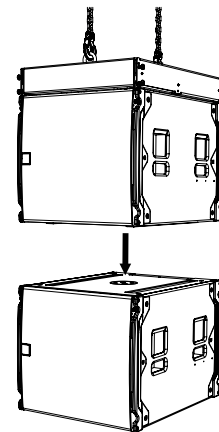

Replace the pins into the lock position on the cabinet above making sure all four links are securely attached.

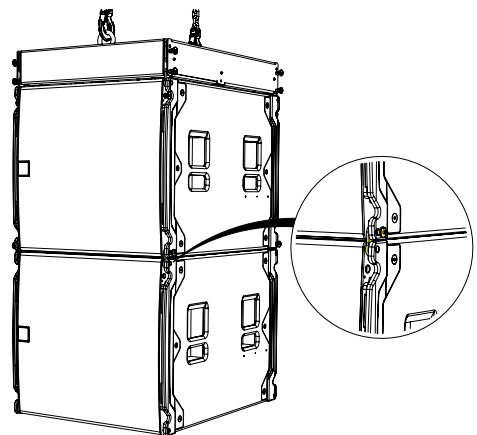



SXCF118



Transit Covers

The SXCF118 features an optional transit cover to protect the cabinet when used in portable applications.

Castors

To fit the castors, remove the M8 counter-sunk screws from the rear of the enclosure.

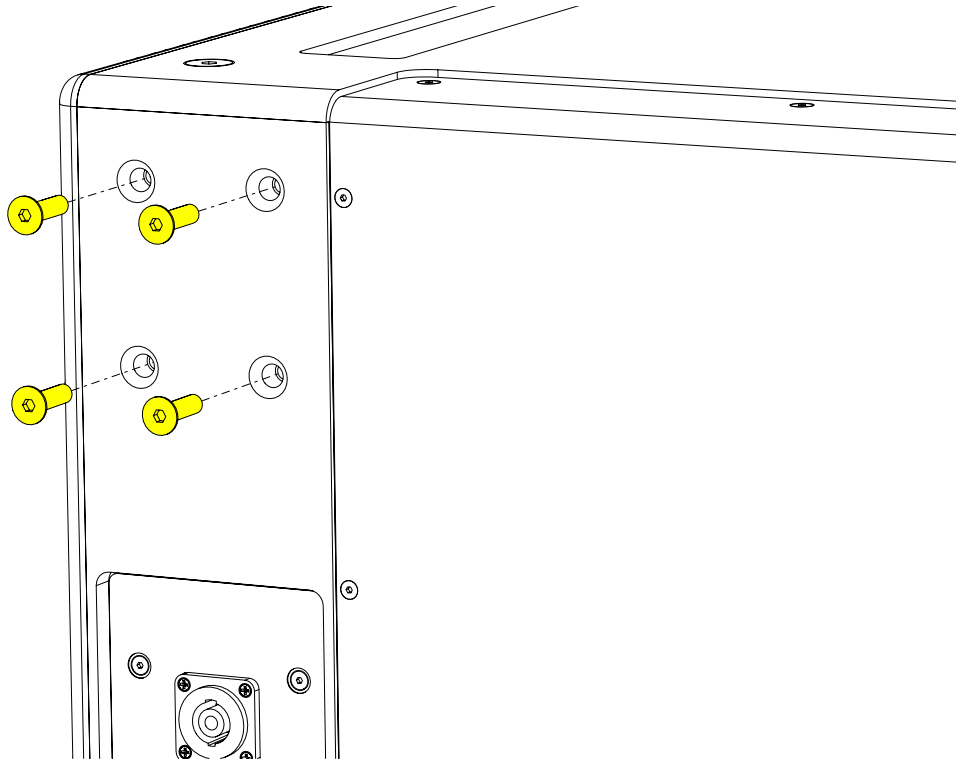

Position each castor over the insets and screw into place using the fixings supplied in the kit.

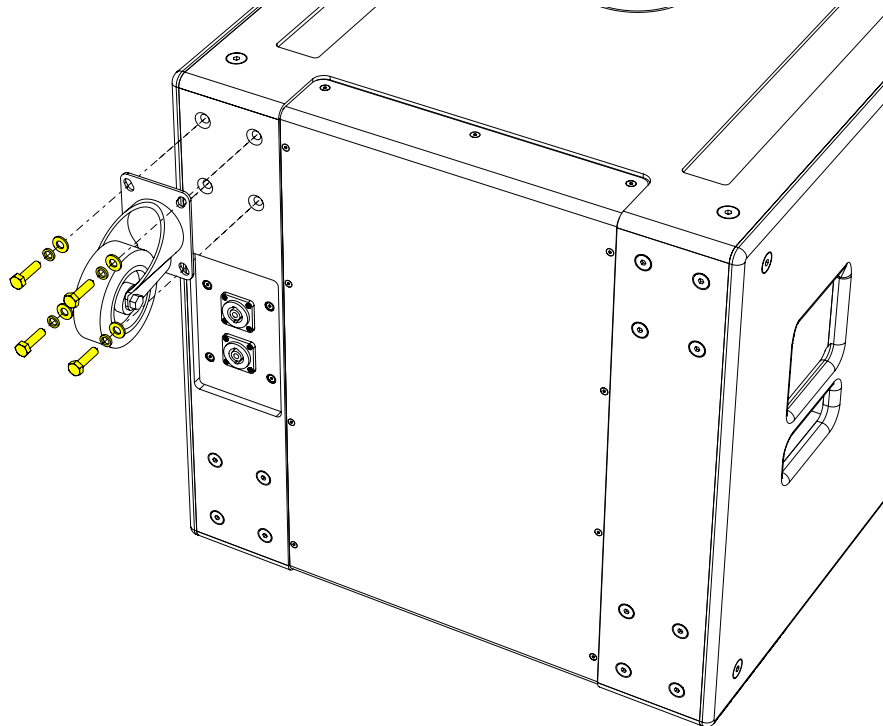

Weather Kit

The WRKIT for non-powered SX Series subwoofers is a glanded cover which fits over the connection panel to prevent water ingress protecting the NL4 speaker connection.

The cable entry may be through one of two knock-out positions depending the angle from which you wish the cable to enter. First remove the knock-out blank that you wish to use and fit the cable gland in position. Note that to use the WRKIT it is necessary to remove the NL4 connector from your speaker cable so the cable can be fed through the cable gland. Once the cable has been threaded through the gland the NL4 can be re-attached.

Remove the four counter-sunk screws in the connector panel and position the cover on the connector panel. Connect the NL4 to the input connector and position the cover, pulling the slack in the speaker cable as you lower the cover in position. Secure the cover using the four M4 x 25 cap socket screws and fibre washers. Finally tighten the gland to ensure a waterproof seal.

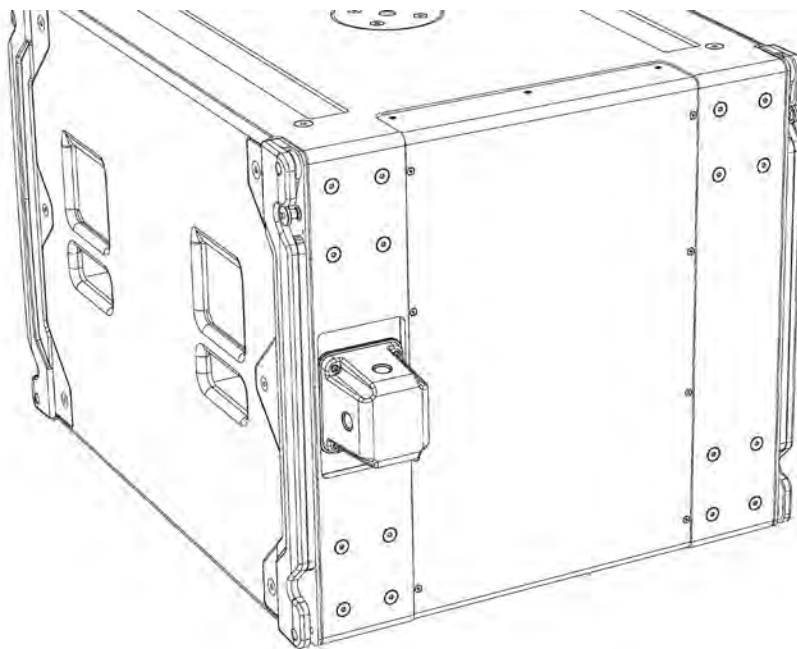
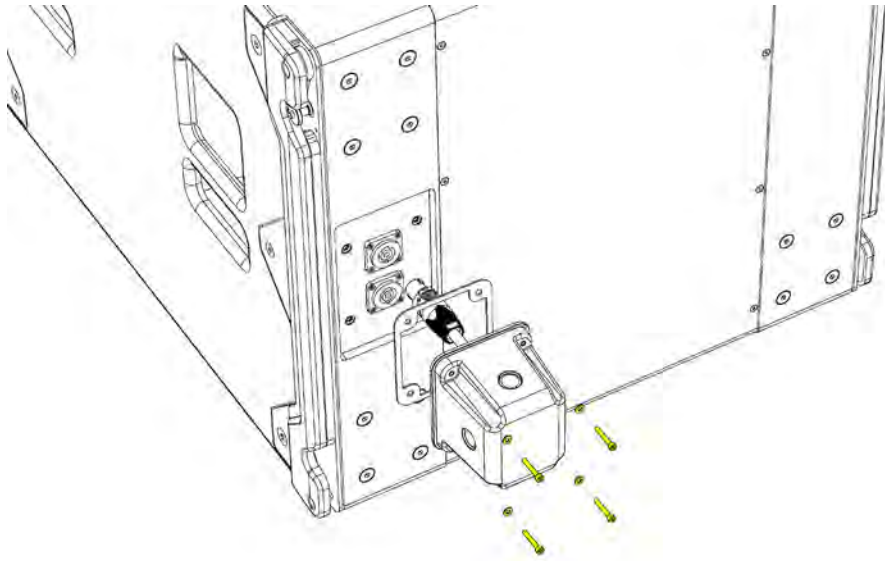

Specifications

TYPE	Compact, cardioid subwoofer
FREQUENCY RESPONSE (1)	43Hz-150Hz ± 3dB, -10dB @ 34Hz
DRIVER	1 x 18" (460mm)/4" (100mm) voice coil, long excursion, ferrite magnet, waterproof cone 1 x 14" (365mm)/3.5" (88mm) voice coil, long excursion, neodymium magnet, waterproof cone
RATED POWER (2)	18": 1000W AES, 4000W peak. 14": 800W AES, 3200W peak
RECOMMENDED AMPLIFIER	IKON iK42
SENSITIVITY (10)	104dB
MAXIMUM SPL (9)	140dB continuous
NOMINAL IMPEDANCE	18": 8 ohms, 14": 8 ohms
DISPERSION	Cardioid
ENCLOSURE	Multi-laminate birch/poplar plywood
FINISH	Textured black paint
PROTECTIVE GRILLE	Black HEX perforated steel
CONNECTORS	2 x NL4
PIN CONNECTIONS (INPUT)	18" +1, -1 14": +2, -2
PIN CONNECTIONS (LINK)	18" +1, -1 14": +2, -2
FITTINGS	Two skids on base, matching channels on top. 2 x bar handles. M20 top-mounted thread plate for pole mounting 16 x M10 mounting points, 4 x fittings for optional transit cover
DIMENSIONS (INCL SKIDS)	(W) 650mm x (H) 611mm x (D) 812mm (940mm including castors)
WEIGHT	75kg (165lbs). 78kg (172lbs) including castors

Notes

- (1) Measured on-axis in half (2pi) space at 2 metres, then referred to 1 metre.
- (2) AES Standard ANSI S4.26-1984.
- (3) Measured in half (2pi) space at 2 metres with 1 watt input, using band limited pink noise, then referred to 1 metre.
- (4) Measured in half (2pi) space at 2 metres using band limited pink noise, then referred to 1 metre.
- (5) Measured on-axis in open (4pi) space at 2 metres, then referred to 1 metre.
- (6) Measured in open (4pi) space at 2 metres with 1 watt input, using band limited pink noise, then referred to 1 metre.
- (7) Measured in open (4pi) space at 2 metres using band limited pink noise, then referred to 1 metre.
- (8) Measured in open (4pi) space at 2 metres with 2.83V input, using band limited pink noise, then referred to 1 metre.
- (9) Calculated at 1 metre.
- (10) Measured in half (2pi) space at 2 metres with 2.83V input, using band limited pink noise, then referred to 1 metre.

Technical Drawing

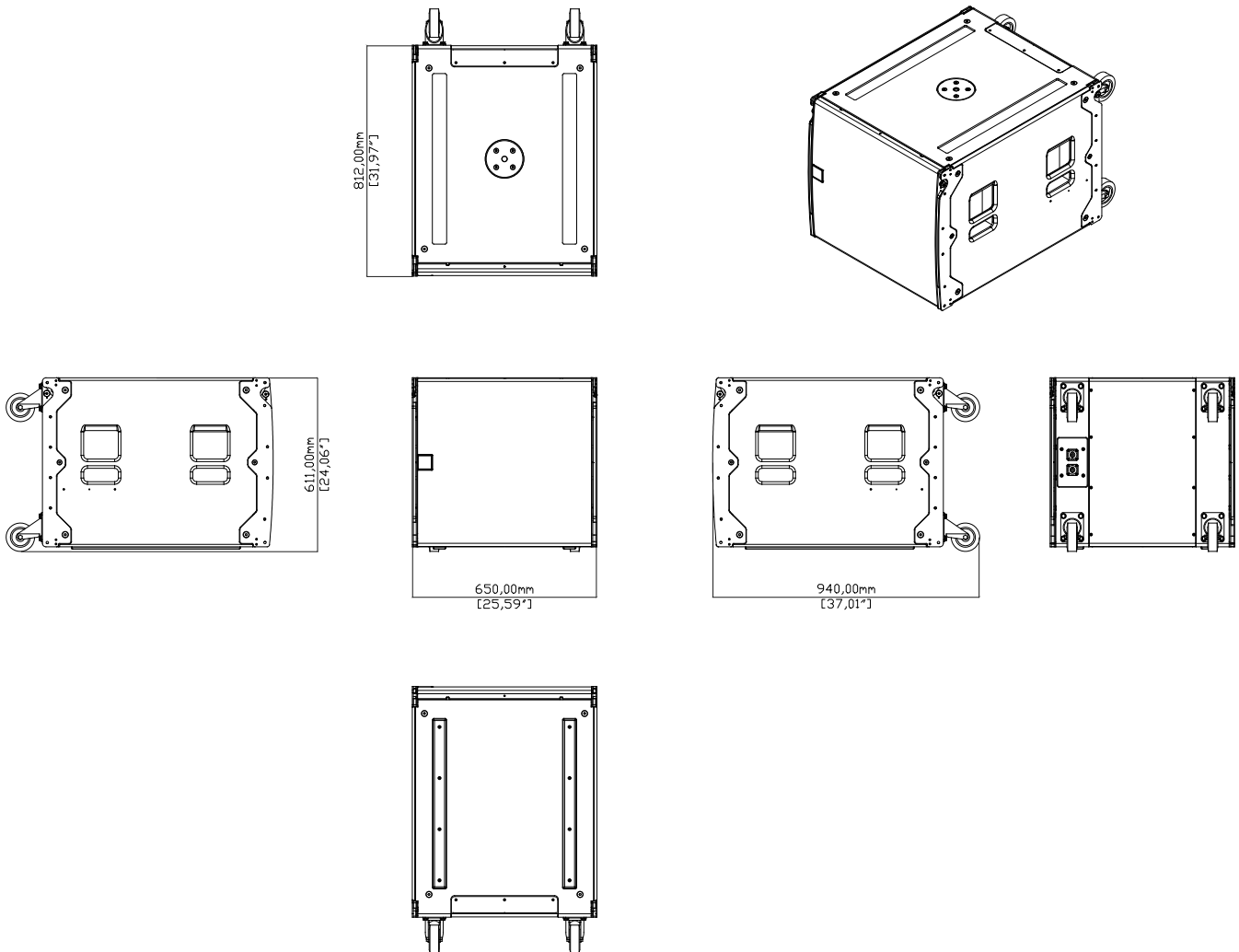

Castors are shown for illustration only and are not included as standard.

SX218



Introduction

The SX218 achieves the ultimate in subwoofer performance for the most demanding applications – delivering very high output levels and superb transient performance with minimal distortion.

With an operating range of 35Hz-150Hz \pm 3dB, it houses dual 18" long excursion (460mm)/4" (100mm) voice coil drivers with water-resistant cones and triple roll surrounds. Each driver is rated to handle 1000 watts AES, and has a magnet structure and suspension engineered for maximum linear excursion.

The enclosure is constructed from multi-laminate birch ply and finished with a durable polyurea coating. Eight reflex ports provide a large frontal area to reduce turbulent air noise, and a perforated steel grille protects the drivers from damage.

The product is supplied as standard without cabinet wheels, but they are available as an accessory.

By adding the input board cover accessory, SX218 is fully weather resistant and suitable for permanent outdoor usage.

A flying system is available for installed systems which require a flown subwoofer solution.

Accessories

M10 eyebolts	HTKCT06
Install flying frame	SX218GRIDi
Flying kit	SX218FKIT
Transit cover	CDDLTC218
Castor kit	WHEELKIT
Wind-up pole	ASF20071
Weather kit	WRKIT

Connections



The SX218 has independent wiring to each of the 18" drivers. This is done so that all four cores of a standard NL4 speaker cable are used to feed the sub, keeping losses through the cable to a minimum. LF driver 1 is connected to pins 1+/-, LF driver 2 is wired to pins 2+/- . The link connector is wired in parallel with the input connector. You can drive the SX218 from two amplifier channels, for example directly out of channel 1 or 3 from an iK42, if you then link the SX218 to a second sub, each amplifier channel will be seeing a 4Ω load. When driving the sub from a single amplifier channel you will need to use a patch panel that links the amplifier output to both pins 1+/- and pins 2+/- and make sure you use a 4-core NL4 cable to connect from your patch panel to the SX218.

Modifying the wiring

The SX218 input panel has a facility to allow quick and easy modification to link both drivers so the connection to pin 1+ is linked to 2+ and 1- to 2-. **Please note that if this modification is done you must not use two channels to drive the SX218, you will effectively be shorting the amplifier channels together which is likely to cause damage.**

To modify the sub, disconnect any speaker cables and carefully remove the panel on which the connector plate is mounted on the rear of the cabinet. There should be enough slack on the cables going to each driver but if not disconnect the cables from each driver making a note of the orientation of the wiring. Turn the panel over to expose the rear of the connector plate. At the top of the plate you will see two pairs of wiring tags. These have a brown, red, black and blue wires feeding them. To convert the wiring solder a short wire link from the brown to the red terminal and a second link from the black to the blue. Re-connect the drivers if these were disconnected ensuring that driver polarity is correct. Refit the panel into the cabinet. We would recommend labelling the connector panel to make it obvious that pins 1 & 2 are now linked.

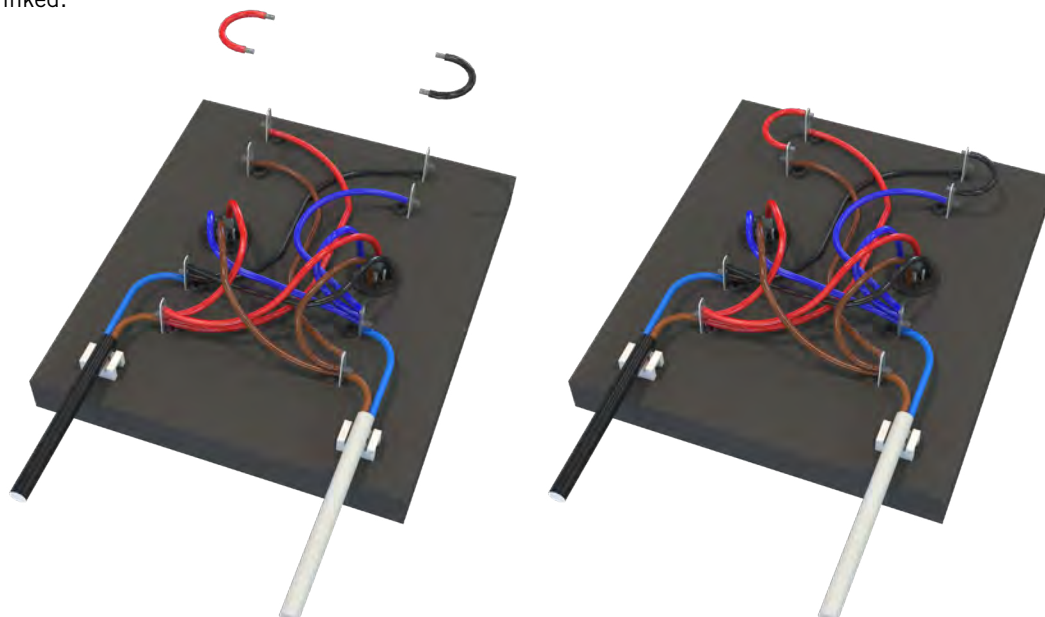

Flying SX218

Eyebolts

The SX218 features M10 inserts to allow flown applications using eyebolts. M10 eyebolts suitable for flown systems are available as accessories from Martin Audio. These are cast steel shouldered eye bolts specifically designed and rated for flown applications. If alternative eyebolts are used these must be cast or machined products stamped with their SWL. Formed steel non-shouldered eyebolts commonly available from DIY stores should not be used under any circumstances as they are not sufficiently load-rated for flown applications.

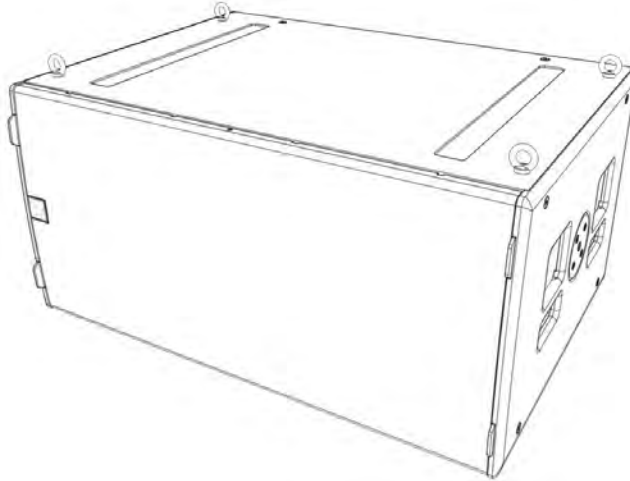

Remove the M10 counter-sunk screws and screw the eyebolts into position. We would recommend four eyebolts and an additional eyebolt as a redundant safety bond. This should be attached to a different point than the other bolts to support the cabinet in the event of the other points failing.

Eyebolts should be connected to a suitably rated fixing point such as a girder clamp or a heavy duty fixing such as a sleeve anchor or similar. They can be linked using suitably rated steel rope or chain and shackles.

Safety note: Flying heavy equipment in public spaces is dangerous and should only be undertaken by suitably qualified and experienced personnel using adequately rated equipment for the task.

Flying Frame and Flying Kit

A flying system is available for the SX218 for installation applications. This uses the SX218FKIT and SX218GRIDI.

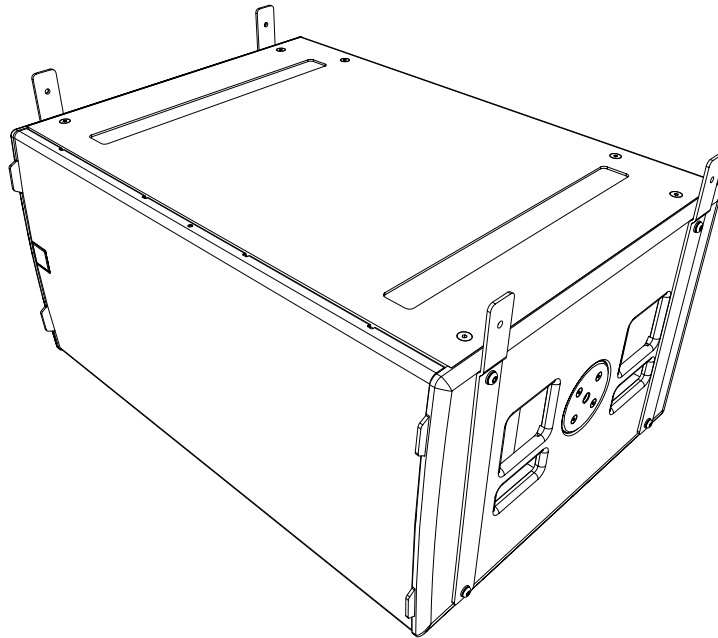

Fit the SX218FKIT flying kit to each cabinet. There are four steel brackets in each kit and these attach vertically, two on each side of the subwoofer. Remove all four M10 bolts in the inserts on the sides of the cabinet.

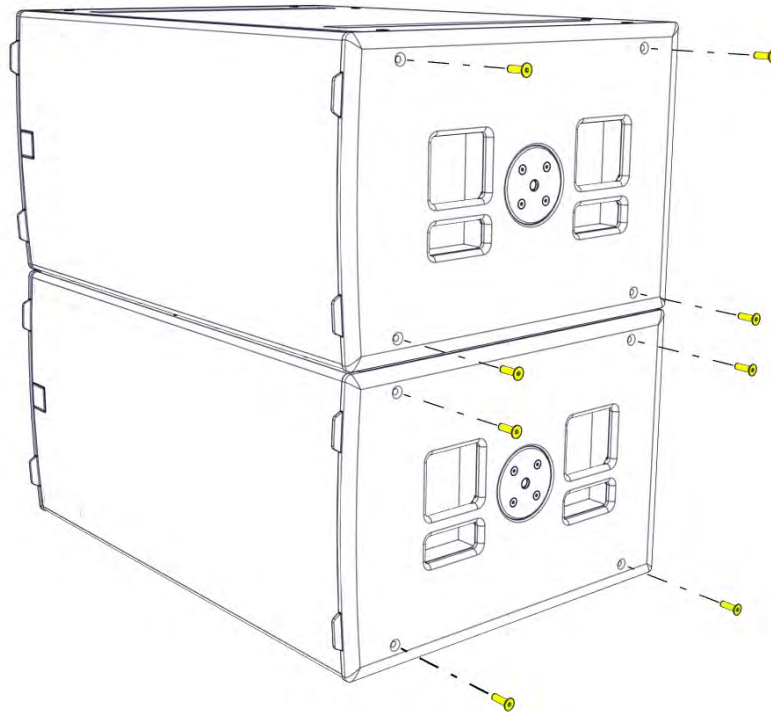

Attach the brackets, two on each with the “dog-leg” in the bracket at the top angled outwards using two M10 bolts and washers in each bracket.

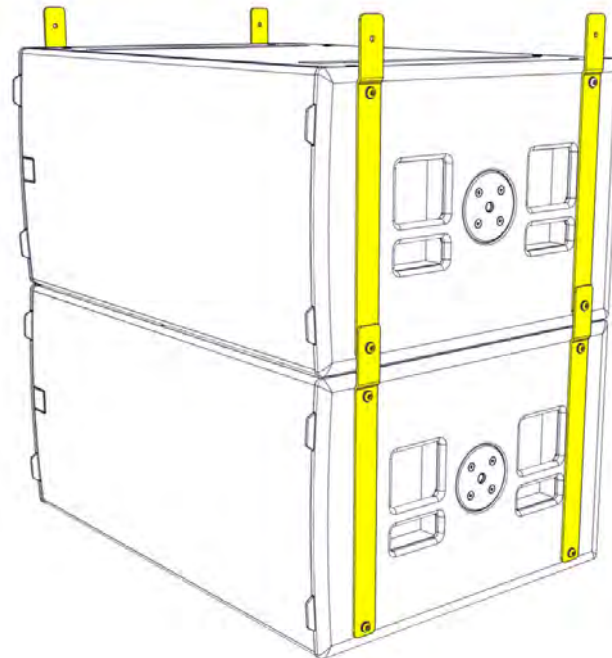
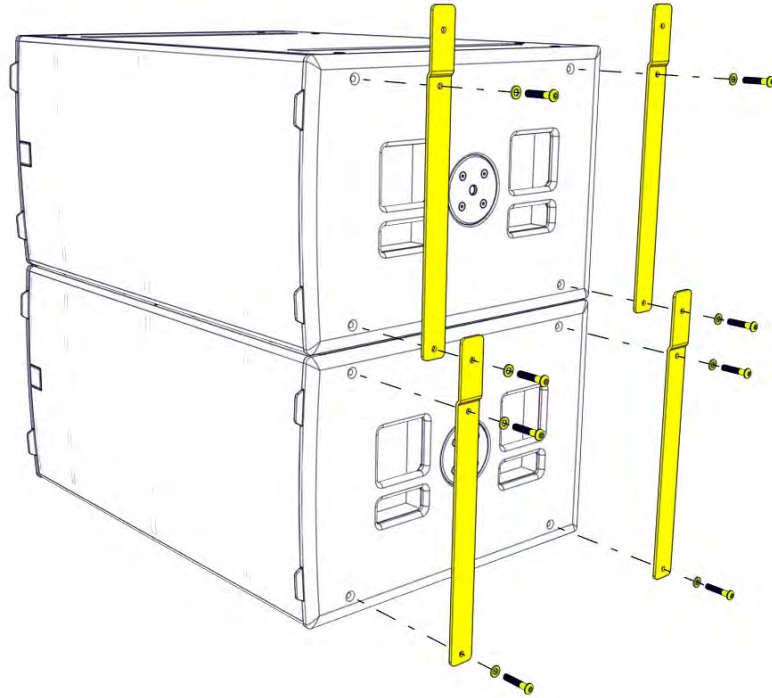

Next the SX218GRiDi should be attached to the two chain hoists that are being used to suspend the sub array. One point is required at the front and a second at the back. The hooks on the hoists can be attached using the two 3.25T Shackles supplied with the grid. Fly the grid out to a height so you can move the SX218 under it then lower the grid to line up the fixing holes on the grid with those on the brackets on the sub.

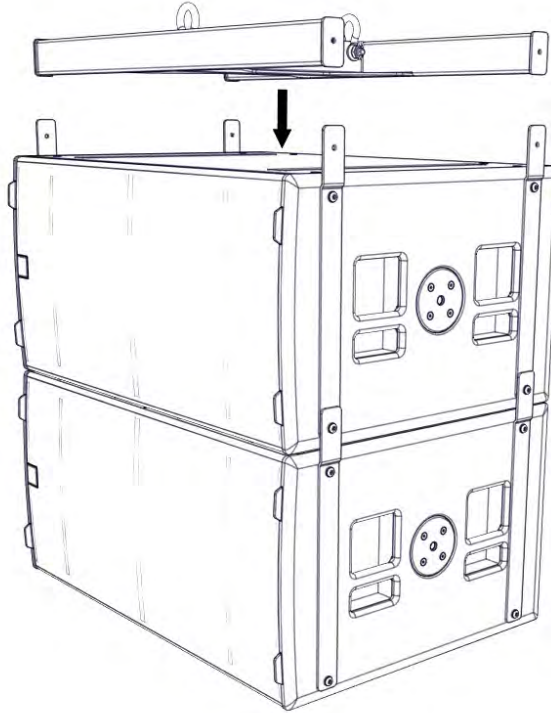

Join using the four M10 x 50 button head screws and washers supplied with the grid assembly. The sub can now be safely flown to the desired height.

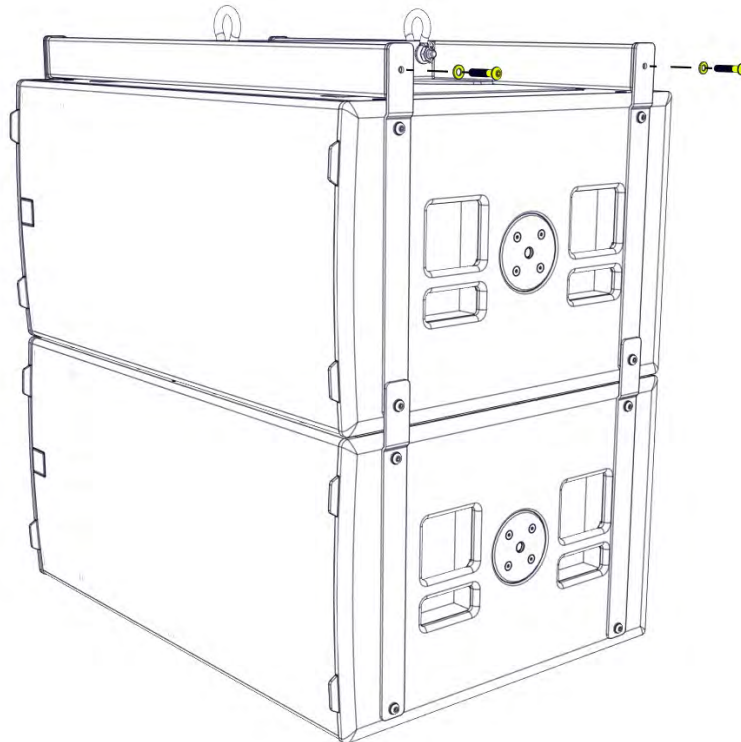

A maximum of six SX218 subwoofers can be flown using this method.

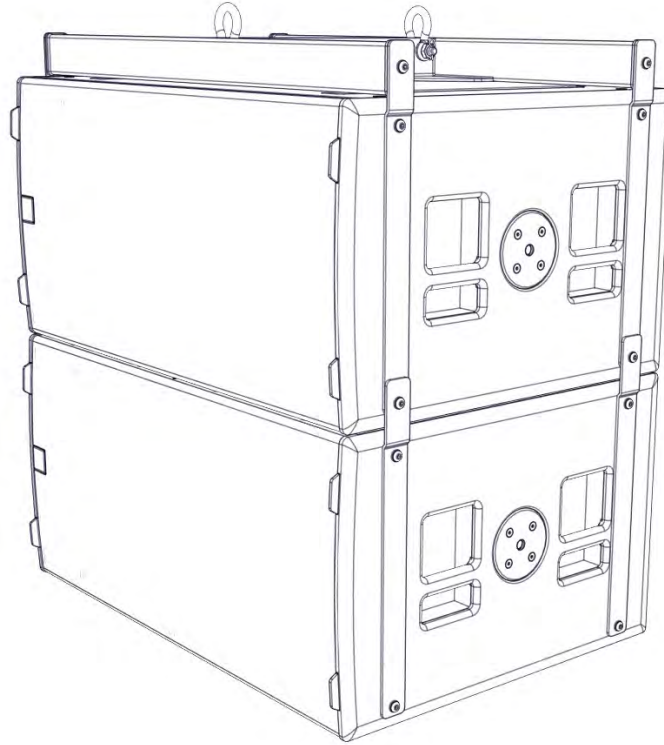

Transit Covers

The SX218 features an optional transit cover to protect the cabinet when used in portable applications.

To ensure that the insert is accurately located, four locating brackets are utilised. These are built into the cabinet in the four corners and may be fitted in the parked position as standard. To use with the transit cover it is necessary to reverse the four brackets.

Remove the top and bottom safety screws from the grille. Insert a flat blade screwdriver into the slots of the grille and carefully easing the grille out of the slot.

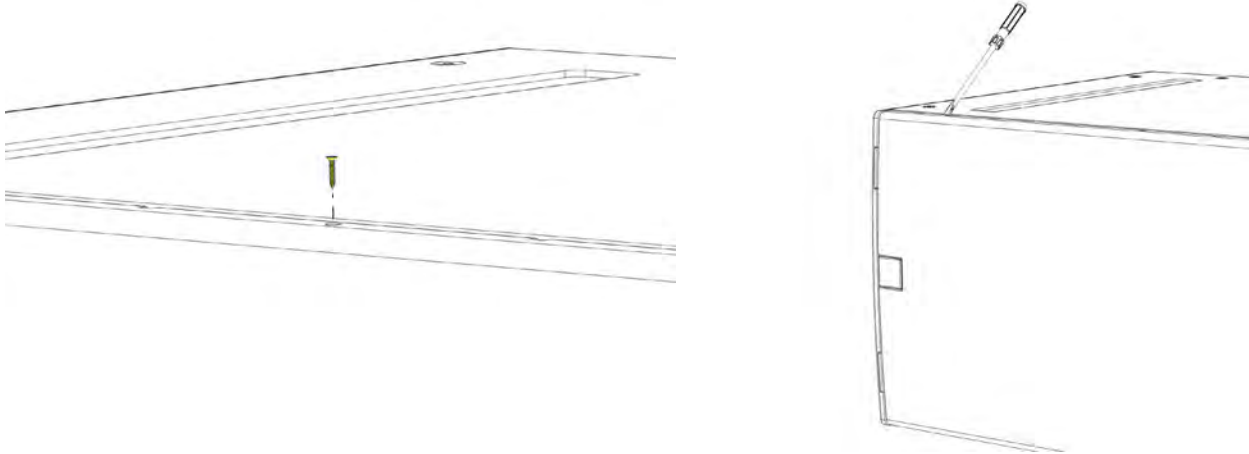

Remove the screws from the grille support on the side of the cabinet and remove the grille support.

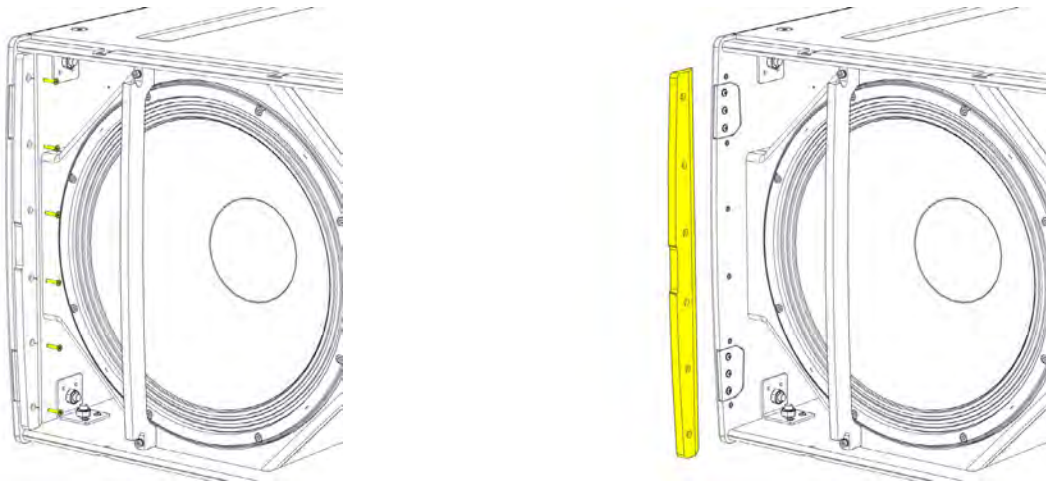

Remove the three screws from the bracket.

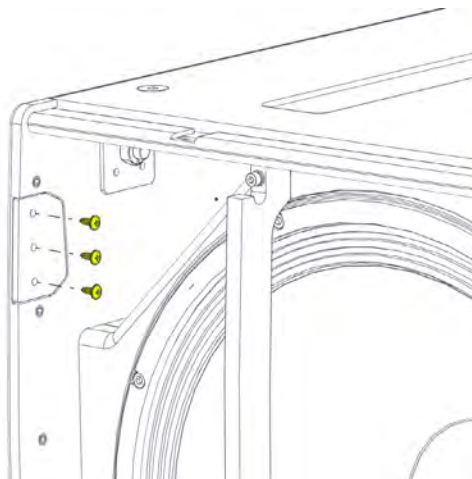

Rotate the bracket 180°. The bracket will now extend approximately 20mm from the front edge of the cabinet, ensure that the slope on the bracket follows the curved contour of the cabinet.

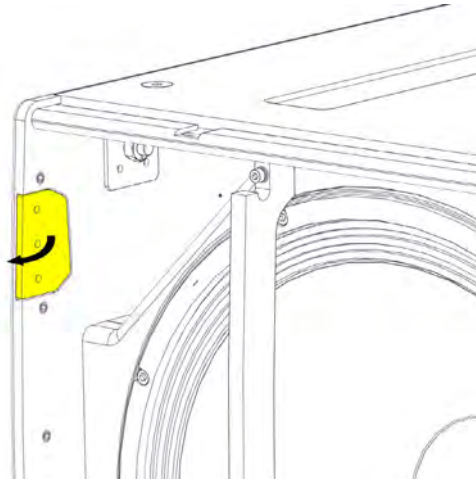

Screw the bracket back in place and repeat for the other three brackets.

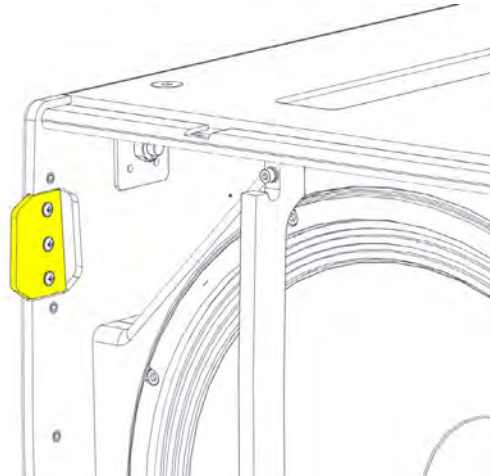
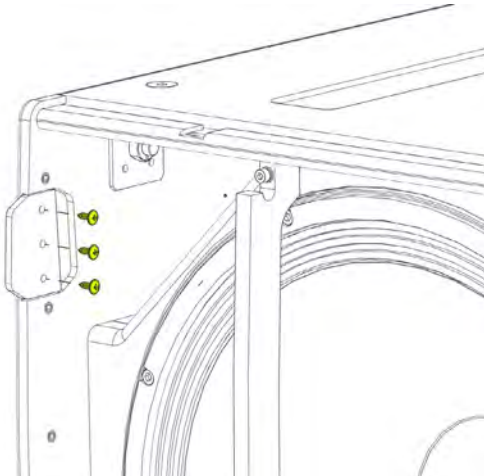

Replace the grill supports and fit the grille making sure the safety screws are used.\

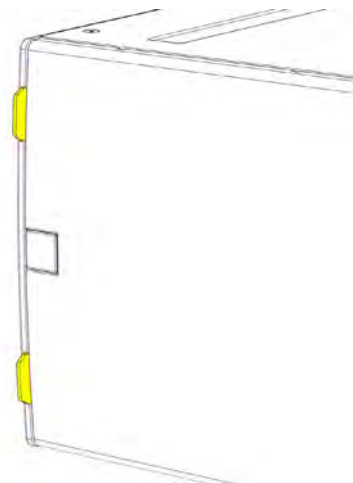
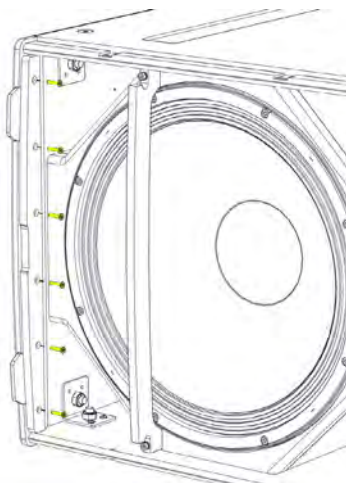

Castors

To fit the castors, remove the M8 counter-sunk screws from the rear of the enclosure.

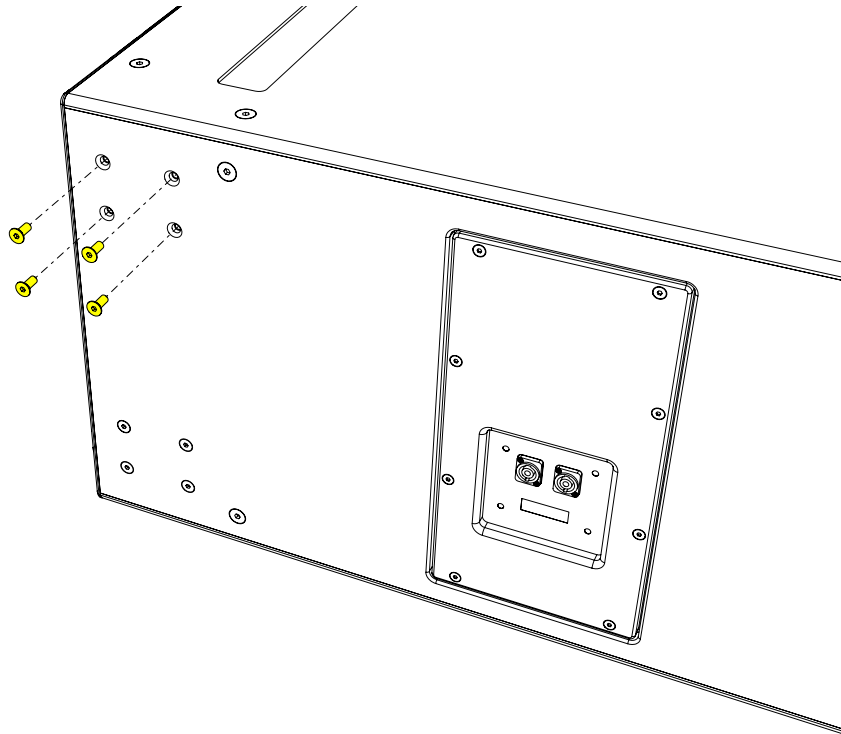

Position each castor over the insets and screw into place using the fixings supplied in the kit.

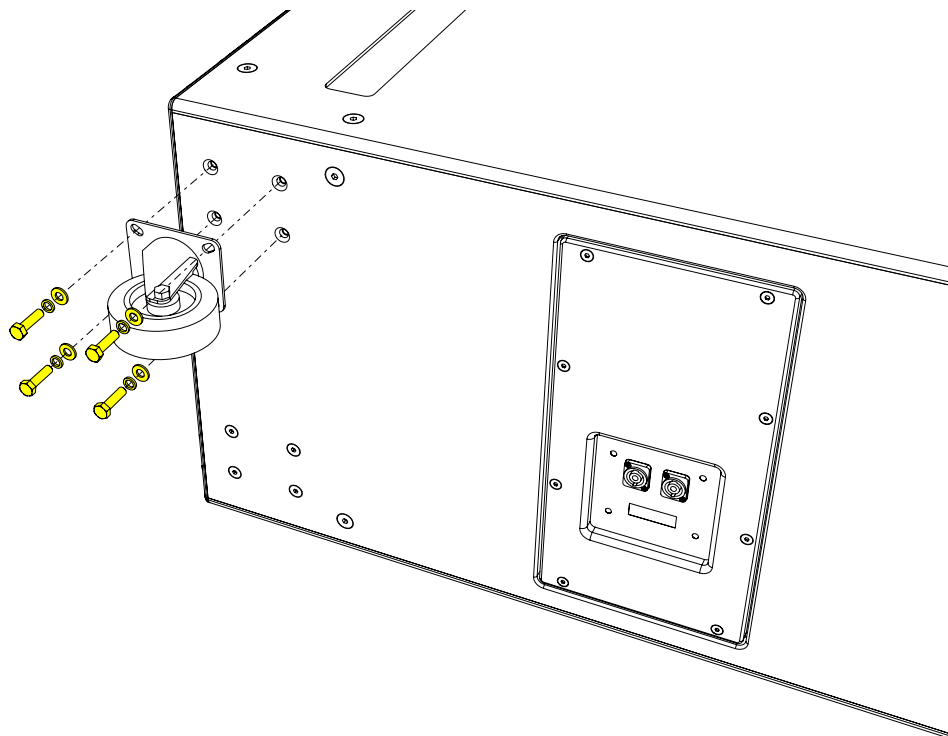

Weather Kit

The WRKIT for non-powered SX Series subwoofers is a glanded cover which fits over the connection panel to prevent water ingress protecting the NL4 speaker connection.

The cable entry may be through one of two knock-out positions depending the angle from which you wish the cable to enter. First remove the knock-out blank that you wish to use and fit the cable gland in position. Note that to use the WRKIT it is necessary to remove the NL4 connector from your speaker cable so the cable can be fed through the cable gland. Once the cable has been threaded through the gland the NL4 can be re-attached.

Remove the four counter-sunk screws in the connector panel and position the cover on the connector panel. Connect the NL4 to the input connector and position the cover, pulling the slack in the speaker cable as you lower the cover in position. Secure the cover using the four M4 x 25 cap socket screws and fibre washers. Finally tighten the gland to ensure a waterproof seal.

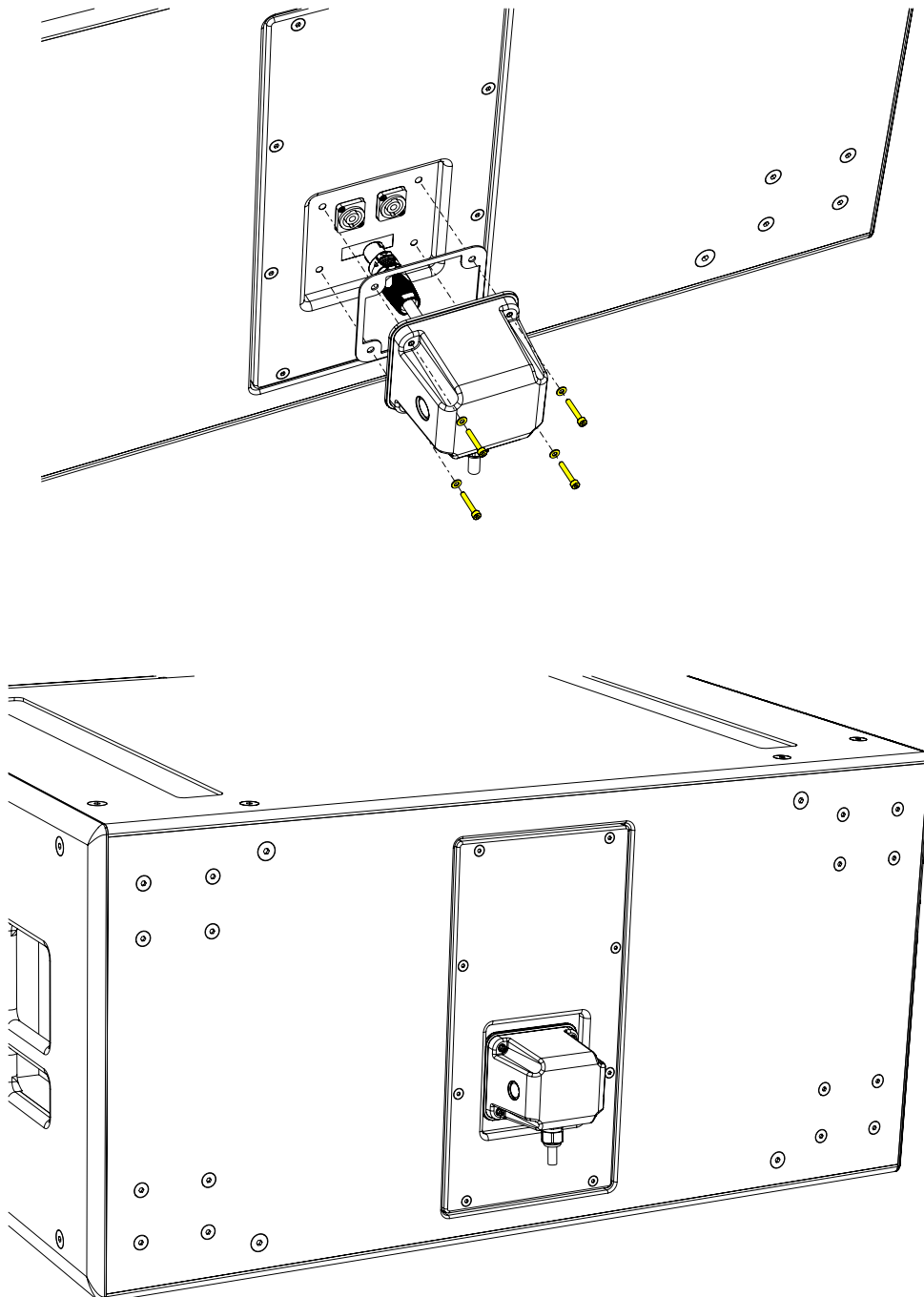

Specifications

TYPE	Compact, direct radiating subwoofer
FREQUENCY RESPONSE (1)	47Hz-150Hz ± 3dB, -10dB @ 41Hz
DRIVER	1 x 18" (460mm)/4" (100mm) voice coil, long excursion, ferrite magnet, waterproof cone
RATED POWER (2)	1000W AES, 4000W peak
RECOMMENDED AMPLIFIER	iK42 / iK81
SENSITIVITY (10)	102dB
MAXIMUM SPL (9)	138dB continuous
NOMINAL IMPEDANCE	8 ohms
DISPERSION (-6dB)	Omnidirectional
CROSSOVER	80-120Hz active
ENCLOSURE	Multi-laminate birch/poplar plywood
FINISH	Textured black paint
PROTECTIVE GRILLE	Perforated steel
CONNECTORS	2 x NL4
PIN CONNECTIONS (INPUT)	LF1: +1, -1 LF2: +2, -2
PIN CONNECTIONS (LINK)	LF1: +1, -1 LF2: +2, -2
FITTINGS	Two skids on base, with mating channels on top Four rear-mounted 100mm (4in) castors 24 x M10 mounting points 4 x bar handles, 2 on each side 4 x fittings for optional transit cover
DIMENSIONS (INCL FEET)	(W) 600mm x (H) 509mm x (D) 632mm (760mm including castors) (W) 23.62in x (H) 20.04in x (D) 24.86in (29.9in including castors)
WEIGHT	47kg (104lbs)

Notes

- (1) Measured on-axis in half (2pi) space at 2 metres, then referred to 1 metre.
- (2) AES Standard ANSI S4.26-1984.
- (3) Measured in half (2pi) space at 2 metres with 1 watt input, using band limited pink noise, then referred to 1 metre.
- (4) Measured in half (2pi) space at 2 metres using band limited pink noise, then referred to 1 metre.
- (5) Measured on-axis in open (4pi) space at 2 metres, then referred to 1 metre.
- (6) Measured in open (4pi) space at 2 metres with 1 watt input, using band limited pink noise, then referred to 1 metre.
- (7) Measured in open (4pi) space at 2 metres using band limited pink noise, then referred to 1 metre.
- (8) Measured in open (4pi) space at 2 metres with 2.83V input, using band limited pink noise, then referred to 1 metre.
- (9) Calculated at 1 metre.
- (10) Measured in half (2pi) space at 2 metres with 2.83V input, using band limited pink noise, then referred to 1 metre.

Technical Drawing

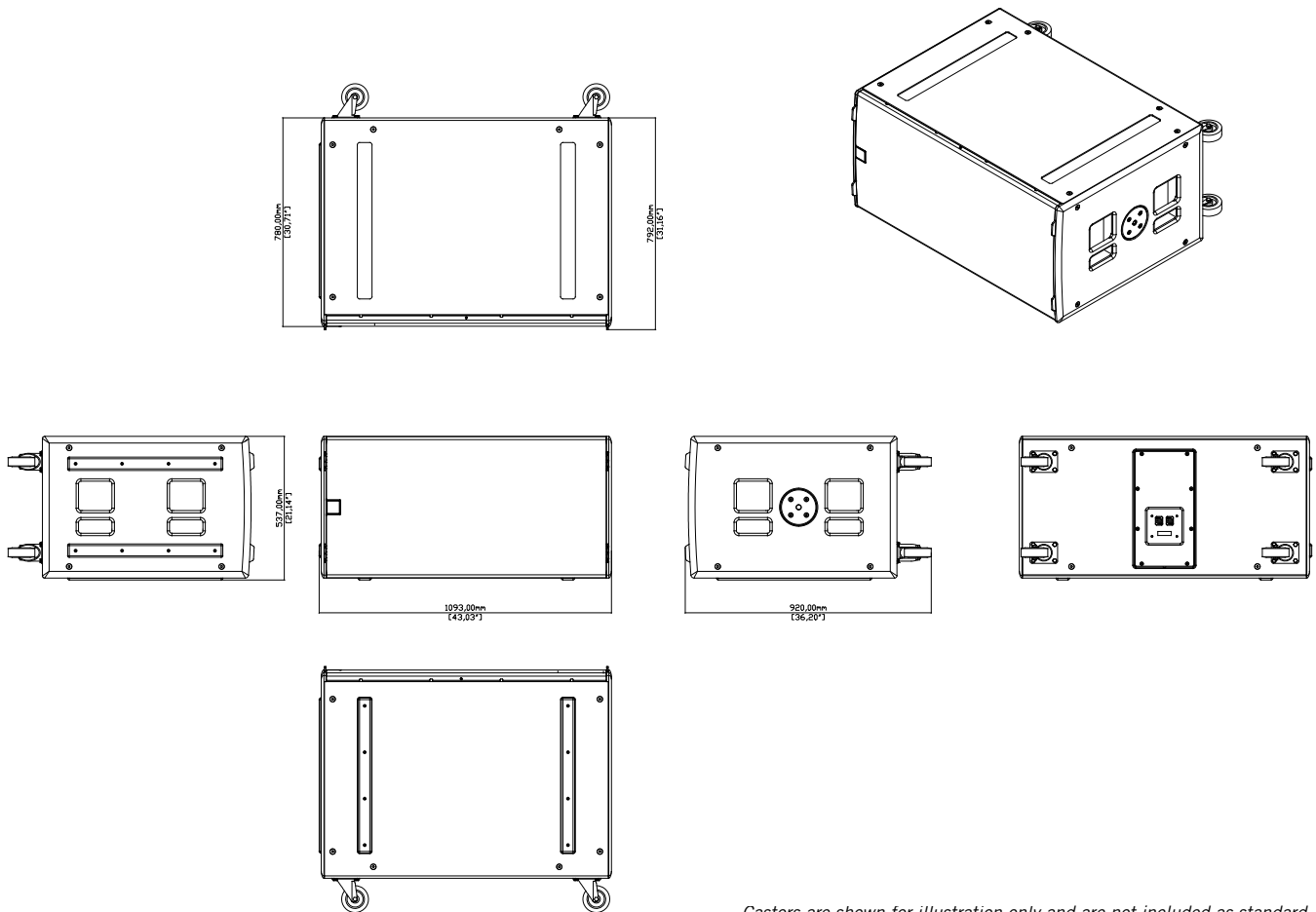

Castors are shown for illustration only and are not included as standard.

SXH218



Introduction

The SXH218 is an extremely powerful subwoofer capable of producing 148dB peak output at 1m. It is the ideal partner for Wavefront Precision WPC arrays where maximum low frequency output is required as well as a standalone solution for premium permanent installations such as nightclubs.

Its Hybrid® horn/reflex loading combines the acoustic efficiency and impact of bass horn technology with the low frequency extension of a reflex design, enabling it to produce significantly higher output levels than a traditional reflex-loaded subwoofer. With an operating range of 32-150Hz + 3dB, it features dual long-excursion 18" (460mm)/4.5" (115mm) voice coil neodymium drivers, with water resistant cones and triple roll surrounds.

The enclosure is constructed from multi-laminate plywood and coated with hardwearing textured black polyurea. A rigid perforated steel grille protects the front of the enclosure, while interlocking skids protect the top and bottom surfaces and prevent movement when stacked.

The SXH218 can be powered by either a single channel of a Martin Audio iK42 4-channel amplifier, or a bridged pair if maximum output is required. Its connector sockets are wired so that one four-core cable from the amplifier will power two SXH218's. SXH218 settings are determined by a pre-determined parameter set in Vu-Net when used in conjunction with iK42, or settings are available from the Martin Audio website when used with alternative amplifiers.

By adding the input board cover accessory, the subwoofer is fully weather resistant and suitable for permanent outdoor usage.

Accessories

Transit cover	SXH218TC
Weather kit	WRKIT

Connections



The SXH218 is connected via a pair of NL4 connectors. This subwoofer features a unique wiring configuration which reverses the connections to the NL4 labelled 'LINK'. It is vital that connections to the iK42 amplifier are made to the INPUT NL4, if connecting to a second SXH218 connect from the 'LINK' out on the first subwoofer to the 'INPUT' on the second sub. Pins 1+/- on the Input are connected to pins 2+/- on the link and pins 2+/- on the input connected to pins 1+/- on the link. This configuration allows a neat cable solution using standard 4-core NL4 cables feeding two amplifier channels and ensuring that each sub is driven by one channel and not seeing a load impedance of less than 4Ω.

The following example shows wiring two SXH218 from independent channels of an iK42 with 4-core speaker cables.

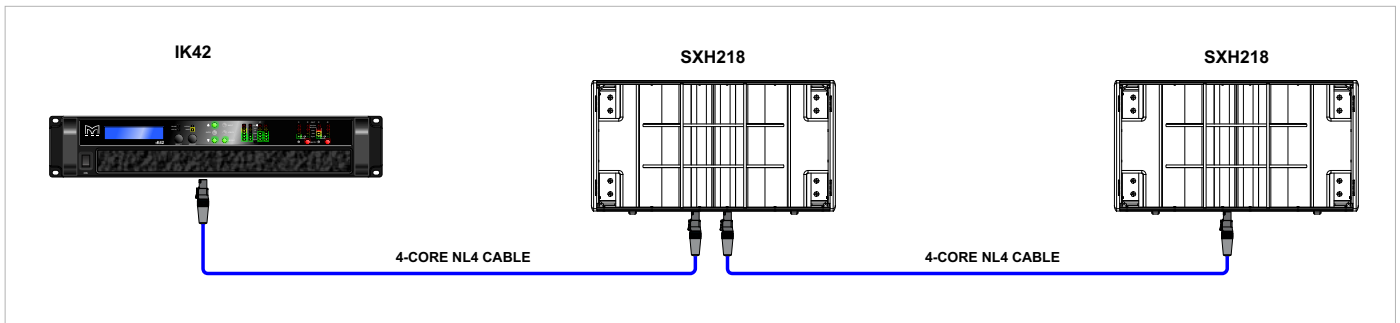

SCHEMATIC

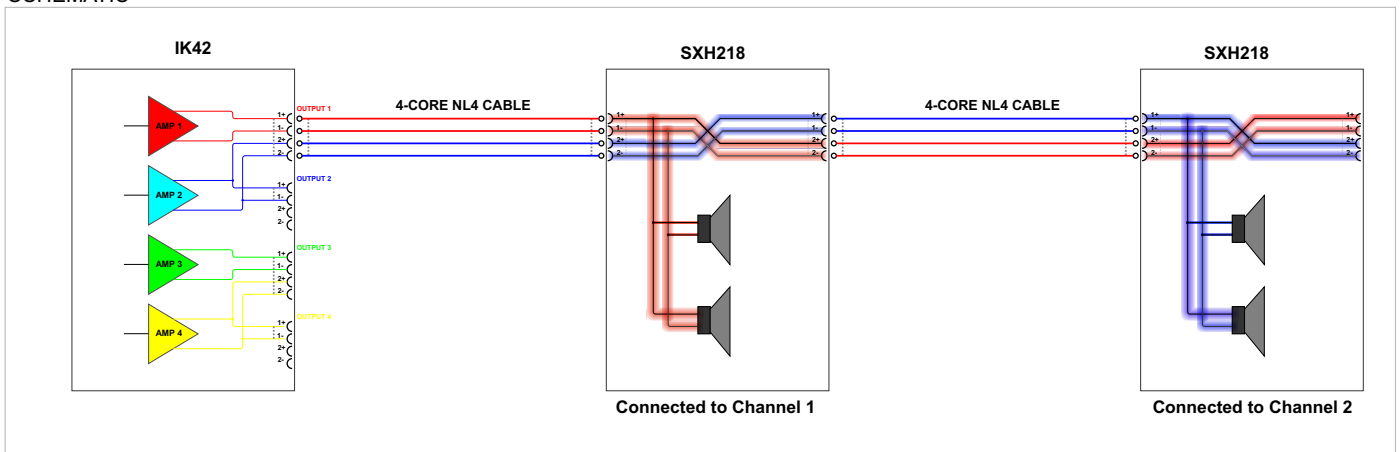

Transit Covers

The SXH218 features an optional transit cover to protect the cabinet when used in portable applications.

To ensure that the insert is accurately located, four locating brackets are utilised. These are built into the cabinet in the four corners and maybe fitted in the parked position as standard. To use with the transit cover it is necessary to reverse the four brackets.

Remove the top and bottom safety screws from the grille. Insert a flat blade screwdriver into the slots of the grille and carefully easing the grille out of the slot.

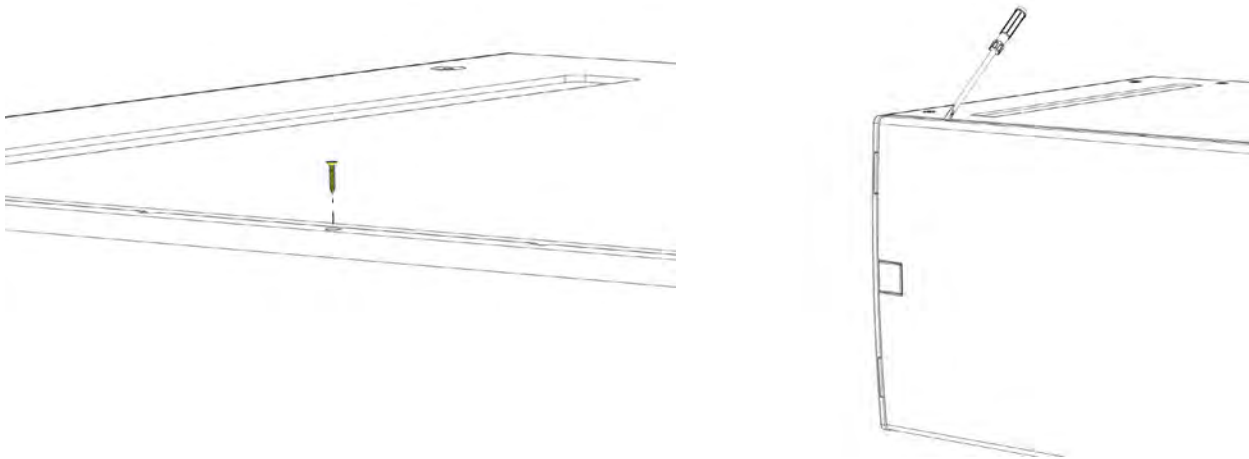

Remove the screws from the grille support on the side of the cabinet and remove the grille support.

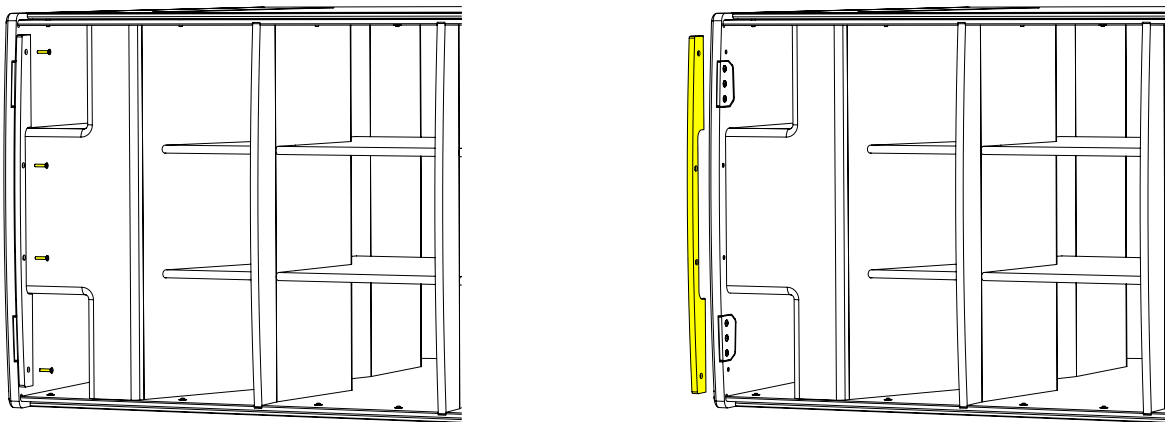

Remove the three screws from the bracket.

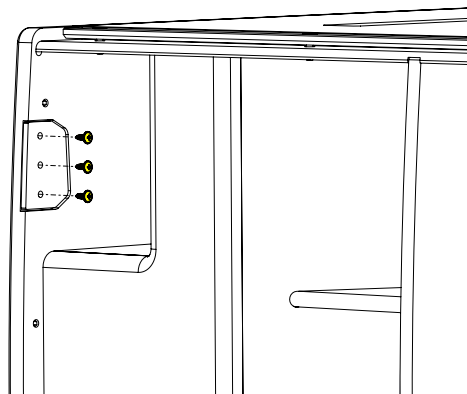

Rotate the bracket 180°. The bracket will now extend approximately 20mm from the front edge of the cabinet, ensure that the slope on the bracket follows the curved contour of the cabinet.

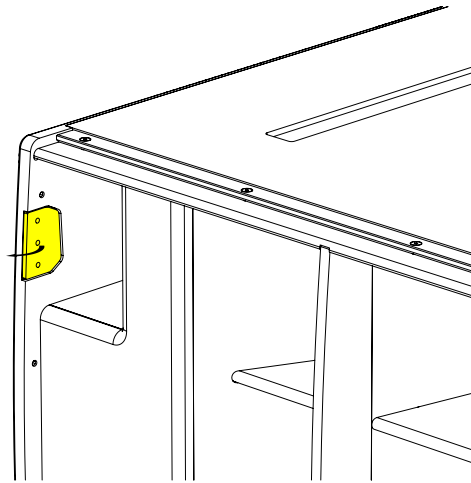

Screw the bracket back in place and repeat for the other three brackets.

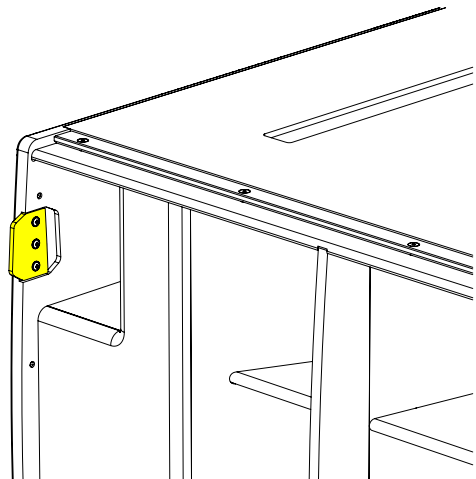
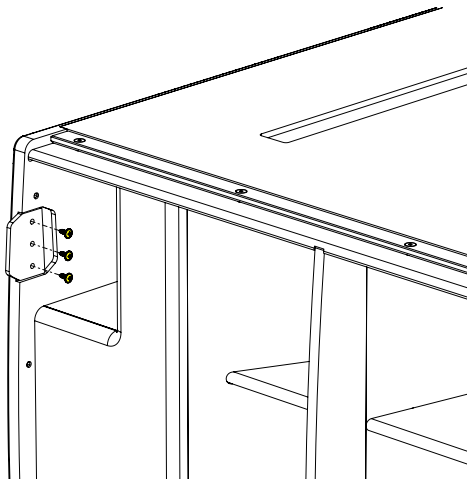

Replace the grill supports and fit the grille making sure the safety screws are used.

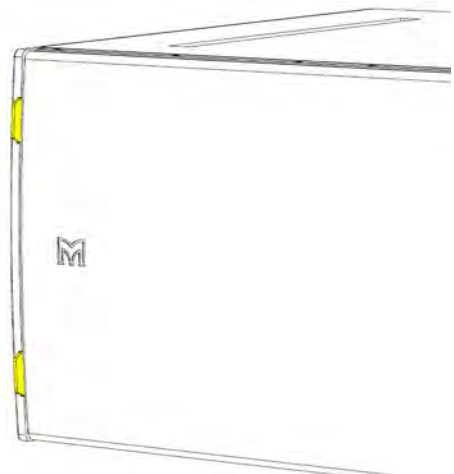
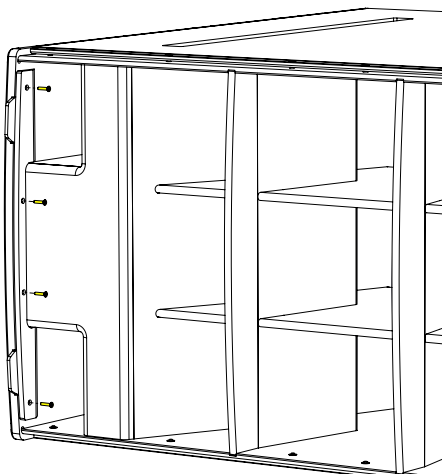

Weather Kit

The WRKIT for non-powered SX Series subwoofers is a glanded cover which fits over the connection panel to prevent water ingress protecting the NL4 speaker connection.

The cable entry may be through one of two knock-out positions depending the angle from which you wish the cable to enter. First remove the knock-out blank that you wish to use and fit the cable gland in position. Note that to use the WRKIT it is necessary to remove the NL4 connector from your speaker cable so the cable can be fed through the cable gland. Once the cable has been threaded through the gland the NL4 can be re-attached.

Remove the four counter-sunk screws in the connector panel and position the cover on the connector panel. Connect the NL4 to the input connector and position the cover, pulling the slack in the speaker cable as you lower the cover in position. Secure the cover using the four M4 x 25 cap socket screws and fibre washers. Finally tighten the gland to ensure a waterproof seal.

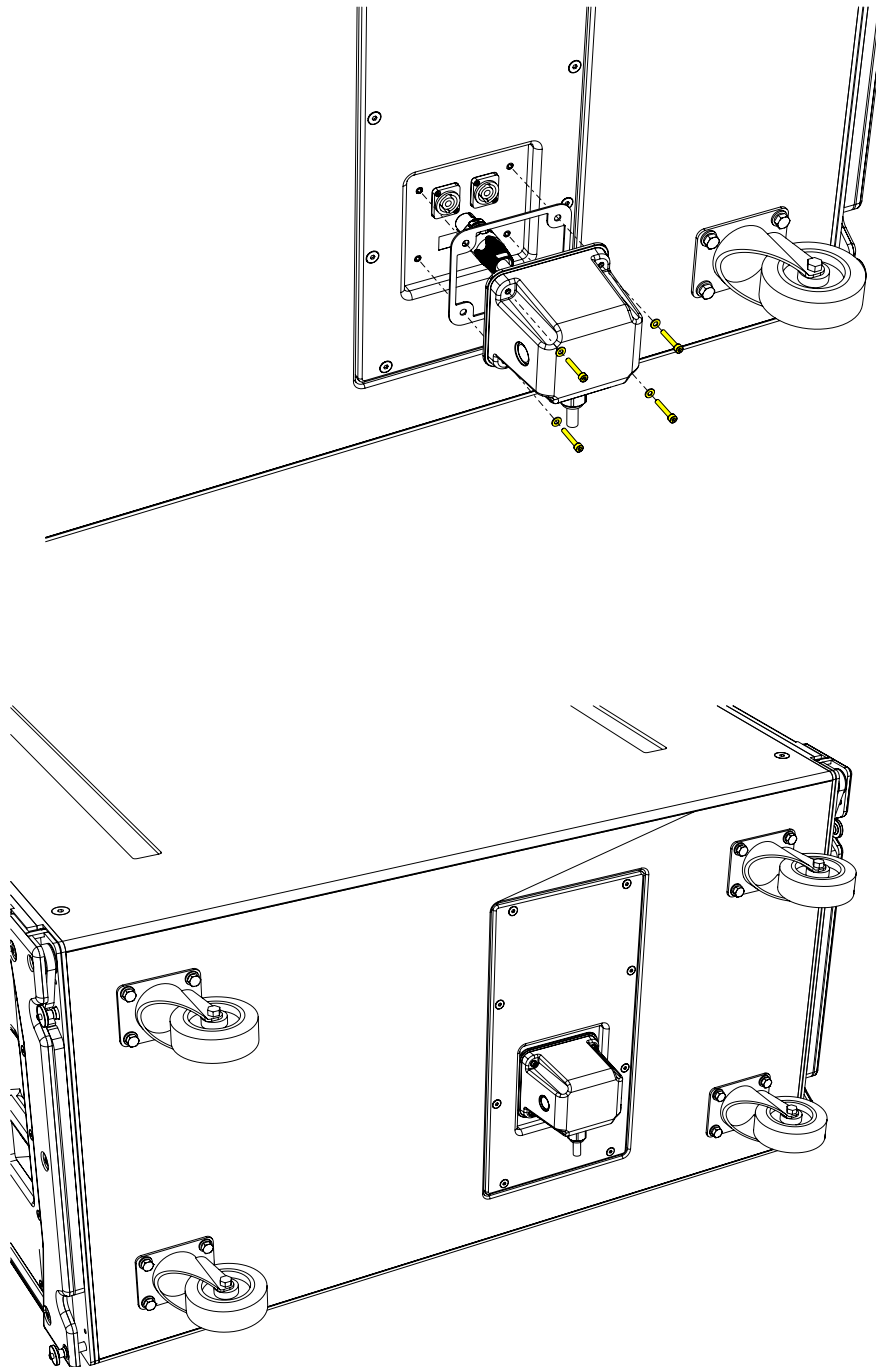

Specifications

TYPE	Hybrid horn/reflex subwoofer
FREQUENCY RESPONSE (1)	32Hz-150Hz ± 3dB, -10dB @ 27Hz
DRIVER	2 x 18" (460mm)/4.5" (115mm) voice coil, long excursion, neodymium magnet, waterproof cone
RATED POWER (2)	3000W AES, 12000W peak
RECOMMENDED AMPLIFIER	iK42
SENSITIVITY (10)	107dB
MAXIMUM SPL (9)	148dB peak (at 1m half space)
NOMINAL IMPEDANCE	4 ohms
DISPERSION (-6dB)	Omnidirectional
CROSSOVER	80-120Hz active
ENCLOSURE	Multi-laminate birch/poplar plywood
FINISH	Textured black paint
PROTECTIVE GRILLE	Perforated steel
CONNECTORS	2 x NL4
PIN CONNECTIONS (INPUT)	+1, -1, refer to input panel for four-core cable link diagram
FITTINGS	Two skids on base, matching channels on top. 4 x bar handles Four rear-mounted 100mm (4in) castors 4 x fittings for optional transit cover
DIMENSIONS (INCL FEET)	(W) 1112mm x (H) 607mm x (D) 1013mm (1140mm including castors) (W) 43.8in x (H) 23.9in x (D) 39.9in (44.9in including castors)
WEIGHT	124kg (273lbs)

Notes

- (1) Measured on-axis in half (2pi) space at 2 metres, then referred to 1 metre.
- (2) AES Standard ANSI S4.26-1984.
- (3) Measured in half (2pi) space at 2 metres with 1 watt input, using band limited pink noise, then referred to 1 metre.
- (4) Measured in half (2pi) space at 2 metres using band limited pink noise, then referred to 1 metre.
- (5) Measured on-axis in open (4pi) space at 2 metres, then referred to 1 metre.
- (6) Measured in open (4pi) space at 2 metres with 1 watt input, using band limited pink noise, then referred to 1 metre.
- (7) Measured in open (4pi) space at 2 metres using band limited pink noise, then referred to 1 metre.
- (8) Measured in open (4pi) space at 2 metres with 2.83V input, using band limited pink noise, then referred to 1 metre.
- (9) Calculated at 1 metre.
- (10) Measured in half (2pi) space at 2 metres with 2.83V input, using band limited pink noise, then referred to 1 metre.

Technical Drawing

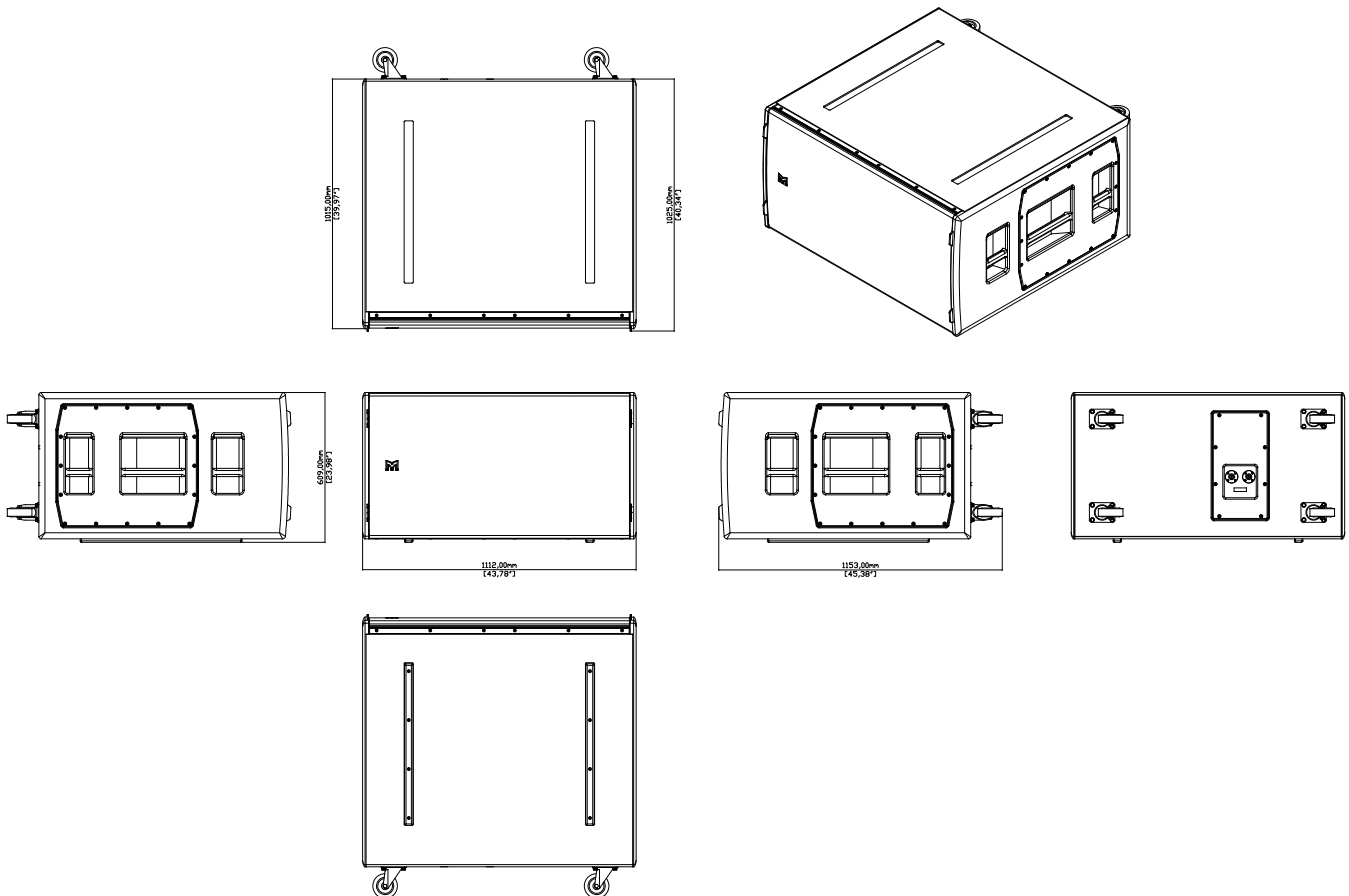

SXHF218



Introduction

The SXHF218 is an extremely powerful subwoofer capable of producing 148dB peak output at 1m. It is the ideal partner for Wavefront Precision WPC and WPL arrays where maximum low frequency output is required as well as a standalone solution for premium permanent installations such as nightclubs.

Its Hybrid® horn/reflex loading combines the acoustic efficiency and impact of bass horn technology with the low frequency extension of a reflex design, enabling it to produce significantly higher output levels than a traditional reflex-loaded subwoofer. With an operating range of 32-150Hz + 3dB, it features dual long-excursion 18" (460mm)/4.5" (115mm) voice coil neodymium drivers, with water resistant cones and triple roll surrounds.

The enclosure is constructed from multi-laminate plywood and coated with hardwearing textured black polyurea. A rigid perforated steel grille protects the front of the enclosure, while interlocking skids protect the top and bottom surfaces and prevent movement when stacked.

The SXH218 can be powered by either a single channel of a Martin Audio iK42 4-channel amplifier, or a bridged pair if maximum output is required. Its connector sockets are wired so that one four-core cable from the amplifier will power two SXH218's. SXH218 settings are determined by a pre-determined parameter set in Vu-Net when used in conjunction with iK42, or settings are available from the Martin Audio website when used with alternative amplifiers.

By adding the input board cover accessory, the subwoofer is fully weather resistant and suitable for permanent outdoor usage.

Accessories

M10 eyebolts	HTKCT06
Transit cover	SXH218TC
Weather kit	WRKIT
Flying frame	WPLGRIDt

Connections



The SXHF218 is connected via a pair of NL4 connectors. This subwoofer features a unique wiring configuration which reverses the connections to the NL4 labelled 'LINK'. It is vital that connections to the iK42 amplifier are made to the INPUT NL4, if connecting to a second SXH218 connect from the 'LINK' out on the first subwoofer to the 'INPUT' on the second sub. Pins 1+/- on the Input are connected to pins 2+/- on the link and pins 2+/- on the input connected to pins 1+/- on the link. This configuration allows a neat cable solution using standard 4-core NL4 cables feeding two amplifier channels and ensuring that each sub is driven by one channel and not seeing a load impedance of less than 4Ω.

The following example shows wiring two SXH218 from independent channels of an iK42 with 4-core speaker cables.

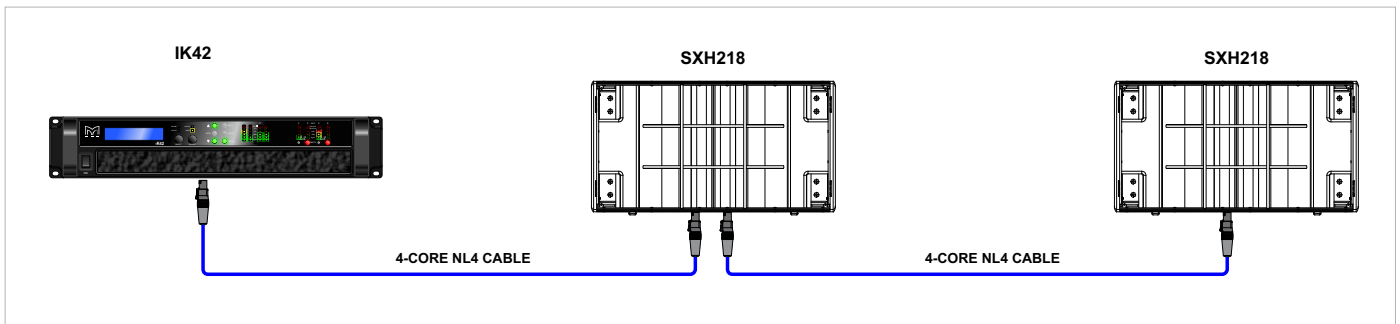

SCHEMATIC

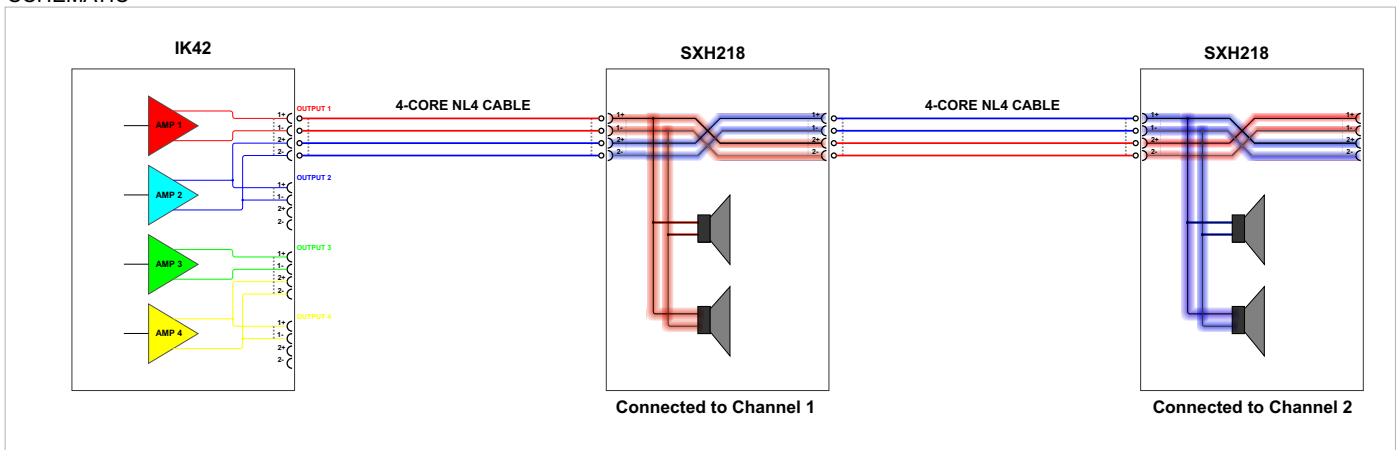

Flying SXHF218

WPLGRIDt

Using one or two motors position a WPLGRIDt above the SCXF118 and lower it onto the enclosure.

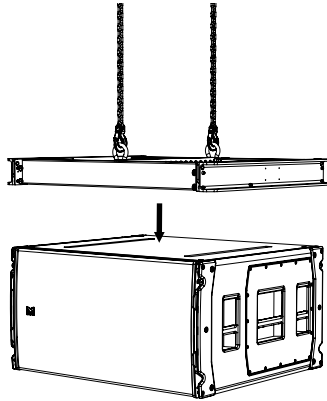

Replace the WPLGRIDt pins to link the SXHF218 securely to the WPLGRIDt. The SXHF218 pins for the first cabinet are not needed in this configuration and can be placed back in the stowed position.

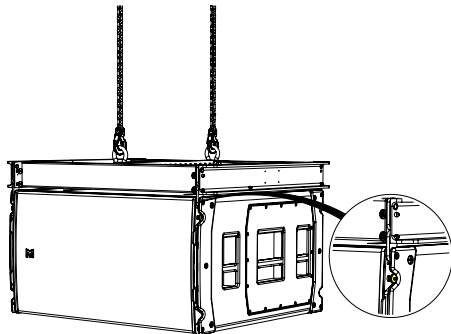

Remove the pins from the stow position, rotate the links to line up with the pin hole position on the SXHF218 above.

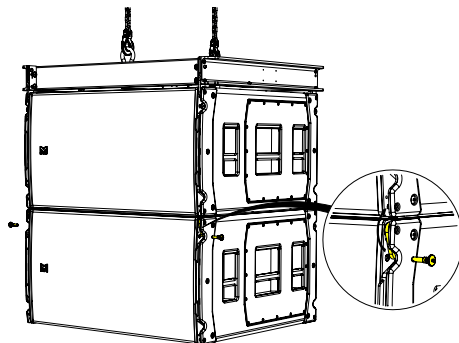

Remove the 4 link pins from the WPLGRIDt and also remove the 4 pins from the from SXHF218 to release the links. Rotate the SXHF218 links and line them up with the pin holes in the WPLGRIDt.

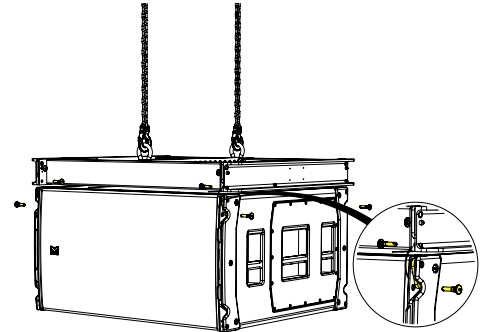

Raise the WPLGRIDt and SXHF218 to a height suitable to fit another SXHF218 below the array, lower it making sure the protective nylon skids line up and fit into the recessed channels on the SXHF218 below.

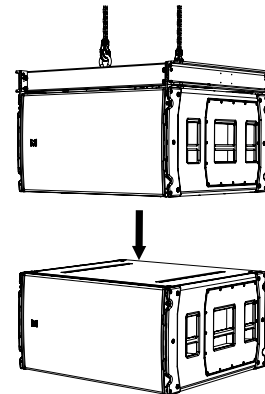

Replace the pins into the lock position on the cabinet above making sure all four links are securely attached. Repeat the process until the correct amount of SXHF218's are flown, the maximum number is 16 SXHF218.

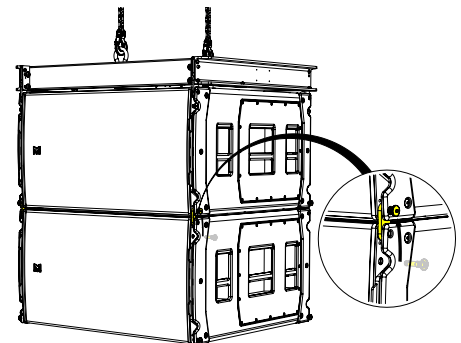

Transit Covers

The SXH218 features an optional transit cover to protect the cabinet when used in portable applications.

To ensure that the insert is accurately located, four locating brackets are utilised. These are built into the cabinet in the four corners and maybe fitted in the parked position as standard. To use with the transit cover it is necessary to reverse the four brackets.

Remove the top and bottom safety screws from the grille. Insert a flat blade screwdriver into the slots of the grille and carefully easing the grille out of the slot.

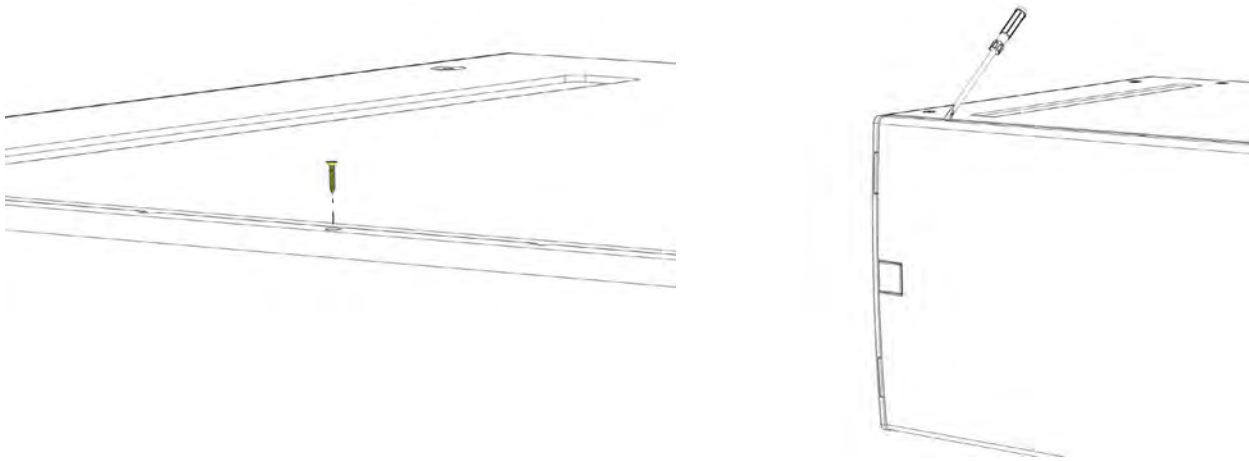

Remove the screws from the grille support on the side of the cabinet and remove the grille support.

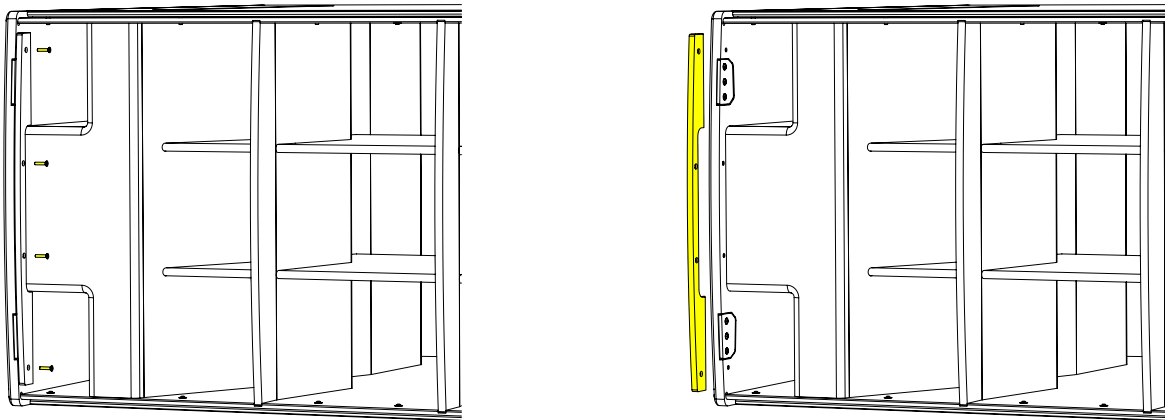

Remove the three screws from the bracket.

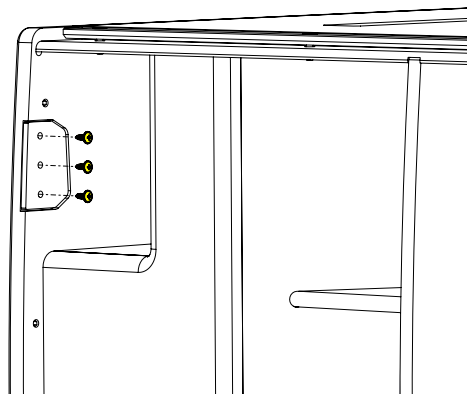

Rotate the bracket 180°. The bracket will now extend approximately 20mm from the front edge of the cabinet, ensure that the slope on the bracket follows the curved contour of the cabinet.

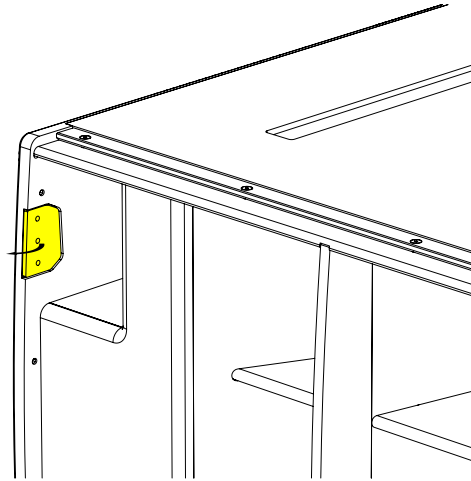

Screw the bracket back in place and repeat for the other three brackets.

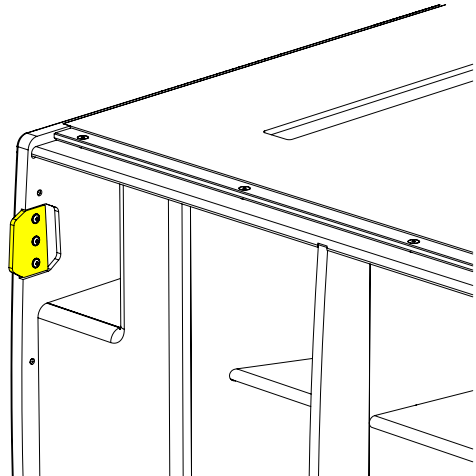
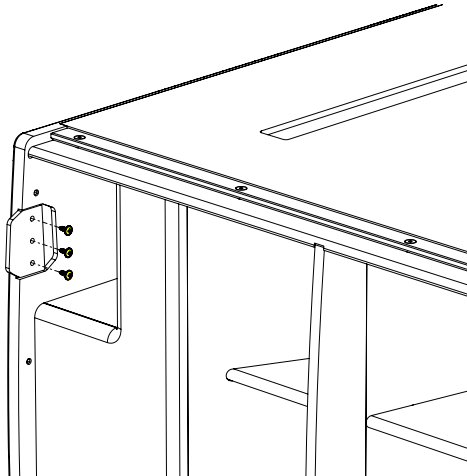

Replace the grill supports and fit the grille making sure the safety screws are used.\

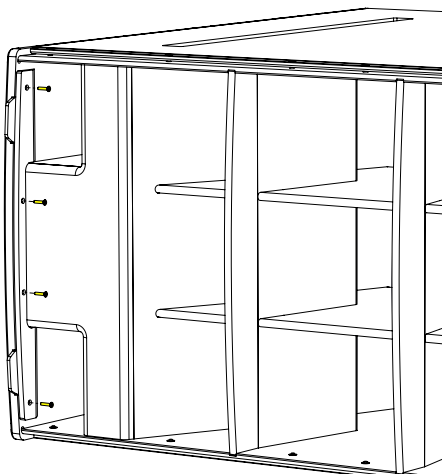

Weather Kit

The WRKIT for non-powered SX Series subwoofers is a glanded cover which fits over the connection panel to prevent water ingress protecting the NL4 speaker connection.

The cable entry may be through one of two knock-out positions depending the angle from which you wish the cable to enter. First remove the knock-out blank that you wish to use and fit the cable gland in position. Note that to use the WRKIT it is necessary to remove the NL4 connector from your speaker cable so the cable can be fed through the cable gland. Once the cable has been threaded through the gland the NL4 can be re-attached.

Remove the four counter-sunk screws in the connector panel and position the cover on the connector panel. Connect the NL4 to the input connector and position the cover, pulling the slack in the speaker cable as you lower the cover in position. Secure the cover using the four M4 x 25 cap socket screws and fibre washers. Finally tighten the gland to ensure a waterproof seal.

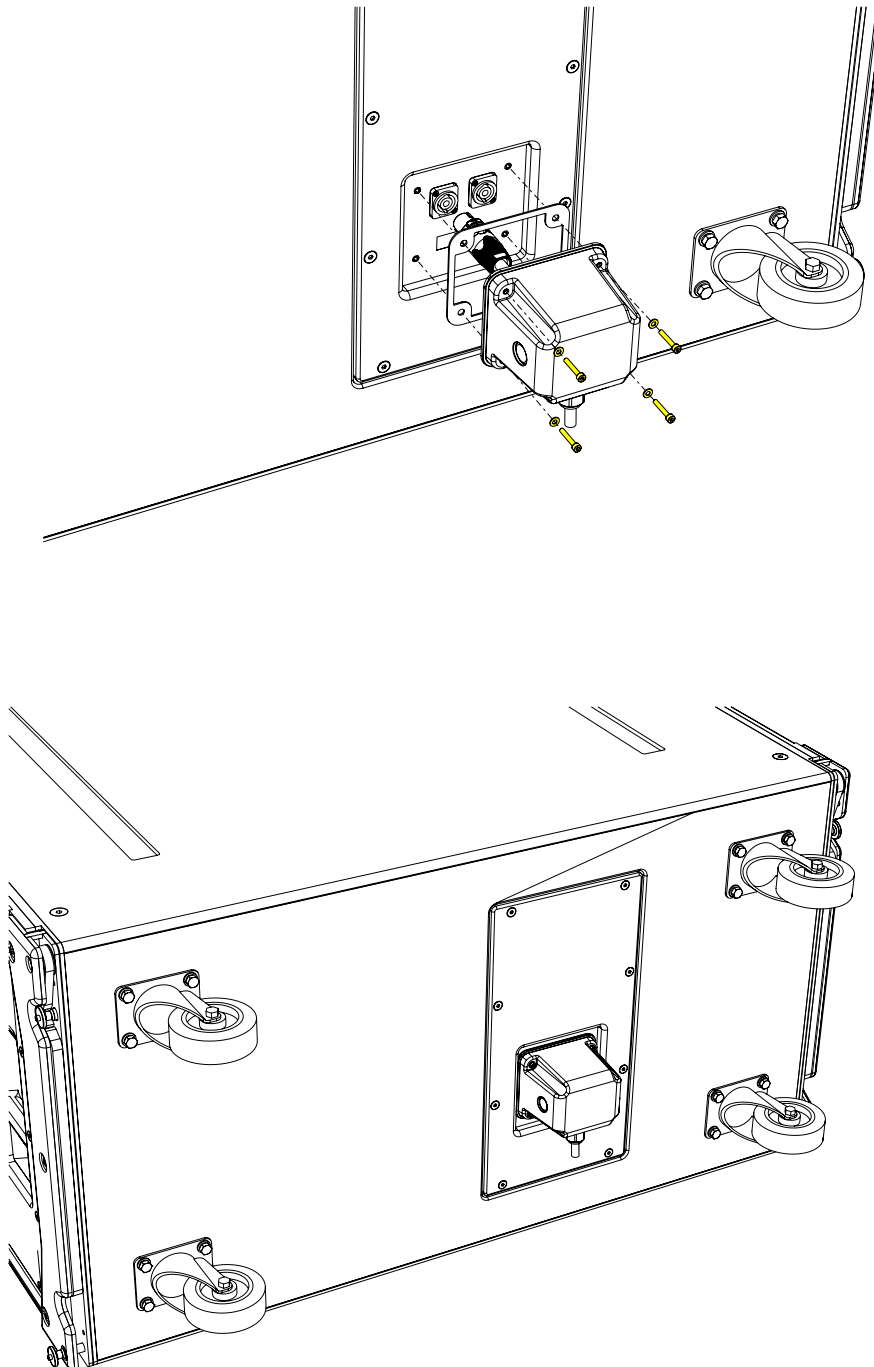

Specifications

TYPE	Hybrid horn/reflex subwoofer
FREQUENCY RESPONSE (1)	32Hz-150Hz ± 3dB, -10dB @ 27Hz
DRIVER	2 x 18" (460mm)/4.5" (115mm) voice coil, long excursion, neodymium magnet, waterproof cone
RATED POWER (2)	3000W AES, 12000W peak
RECOMMENDED AMPLIFIER	IKON iK42
SENSITIVITY (10)	107dB
MAXIMUM SPL (9)	148dB peak (at 1m half space)
NOMINAL IMPEDANCE	4 ohms
DISPERSION (-6dB)	Omnidirectional/or Cardioid (paired)
CROSSOVER	80-120Hz active
ENCLOSURE	Multi-laminate birch/poplar plywood
FINISH	Textured black Polyurea
PROTECTIVE GRILLE	Black perforated steel
CONNECTORS	2 x NL4
PIN CONNECTIONS (INPUT)	+1, -1, refer to input panel for four-core cable link diagram
FITTINGS	Two skids on base, matching channels on top. 4 x bar handles Four rear-mounted 100mm (4in) castors 4 x fittings for optional transit cover
DIMENSIONS (INCL SKIDS)	(W) 1148mm x (H) 604mm x (D) 1027mm (1155mm including castors) (W) 45.2in x (H) 23.8in x (D) 40.4in (45.5in including castors)
WEIGHT	138kg (204lbs), with castors 146.5kg (323lbs)

Notes

- (1) Measured on-axis in half (2pi) space at 2 metres, then referred to 1 metre.
- (2) AES Standard ANSI S4.26-1984.
- (3) Measured in half (2pi) space at 2 metres with 1 watt input, using band limited pink noise, then referred to 1 metre.
- (4) Measured in half (2pi) space at 2 metres using band limited pink noise, then referred to 1 metre.
- (5) Measured on-axis in open (4pi) space at 2 metres, then referred to 1 metre.
- (6) Measured in open (4pi) space at 2 metres with 1 watt input, using band limited pink noise, then referred to 1 metre.
- (7) Measured in open (4pi) space at 2 metres using band limited pink noise, then referred to 1 metre.
- (8) Measured in open (4pi) space at 2 metres with 2.83V input, using band limited pink noise, then referred to 1 metre.
- (9) Calculated at 1 metre.
- (10) Measured in half (2pi) space at 2 metres with 2.83V input, using band limited pink noise, then referred to 1 metre.

Technical Drawing

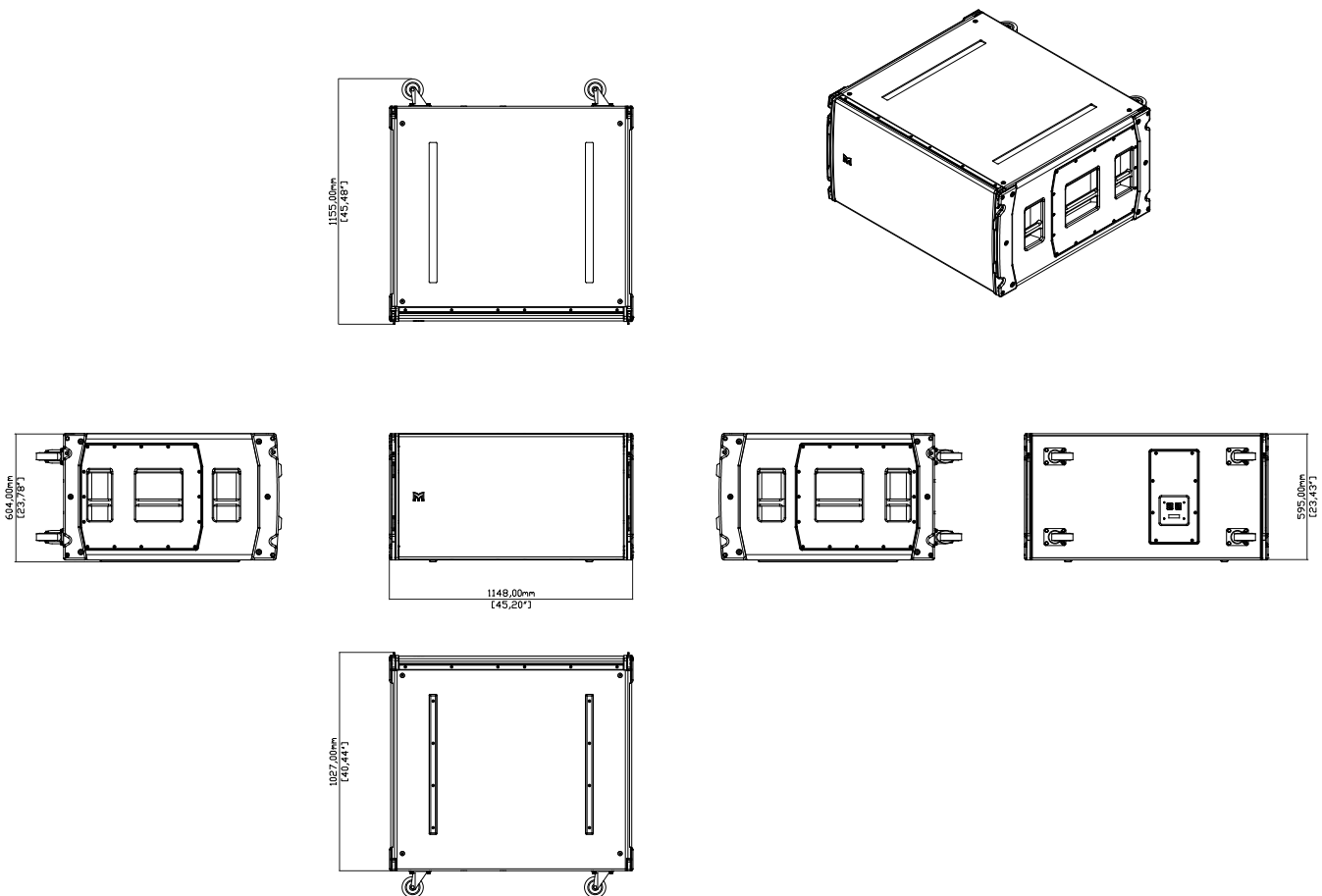

SXP118



Introduction

The SXP118 is a compact, high-performance subwoofer that extends the low frequency operating range of a CDD-LIVE full-range system to 40Hz — providing exceptional low frequency impact and increasing headroom. It features a long-excursion 18" (460mm)/4" (100 mm) voice coil driver with a water-resistant cone and triple roll surround in a compact reflex enclosure.

The design of the 18" driver maximises output while minimising power compression and distortion, and the four reflex ports have a large frontal area to reduce turbulent air noise at very high levels. With a maximum SPL capability of 135dB peak at 1 metre, the SXP118 is the ideal subwoofer for theatre and portable live sound applications, as well as premium installations that require the maximum output from a compact enclosure.

A self-powered system, the SXP118 incorporates a Class D amplifier, DSP and Dante™ digital audio networking — simplifying set-up, enhancing control and eliminating amplifier racks. The onboard amplifier delivers 2000W peak output to the driver, and its switched-mode power supply auto-ranges to global mains voltages from 100 to 240V 50/60Hz. DSP functions — including parametric EQ, delay, muting, gain and preset selection — can be controlled over Ethernet from a PC or Windows® tablet via intuitive VU-NET™ proprietary software.

Accessories

M10 eyebolts	HTKCT06
Transit cover	CDDLTC118
Castor kit	WHEELKIT
Wind-up pole	ASF20071
Weather kit	CDDLK118/218

Connections

The SXP118 is a powered subwoofer and shares its connections with the CDD-LIVE range. There are three types of connection on each sub, consisting of mains, analogue XLR and Network Ethercon.







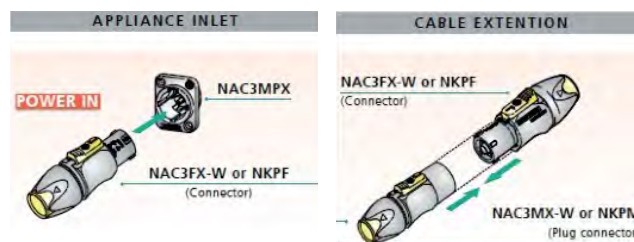

Mains

The mains inlet is a Neutrik® PowerCon True1 socket and a mating connector is supplied with each CDD-LIVE speaker. The True1 is the latest version of Neutrik's PowerCon range and is a small, light, rugged, inexpensive latching mains connector rated for use up to 240V at 16A. It is rated with a breaking capacity according to IEC60320 and VDE0625 meaning that it can be connected and disconnected without first turning off the power feed. This has the advantage of being very convenient but also makes a power switch unnecessary as it is easy to turn the speaker off by activating the latch and turning the connector anticlockwise which will disconnect the power whilst leaving the plug in place in the socket so it can be quickly rotated clockwise to restore the power connection when required.

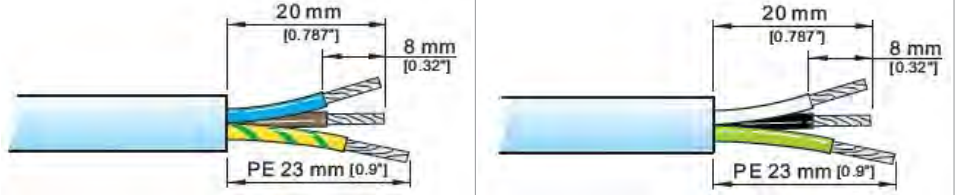
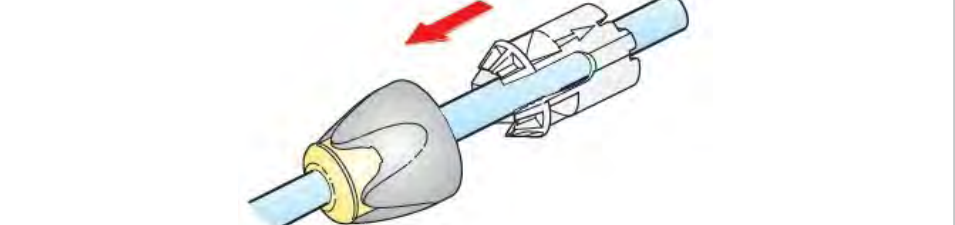
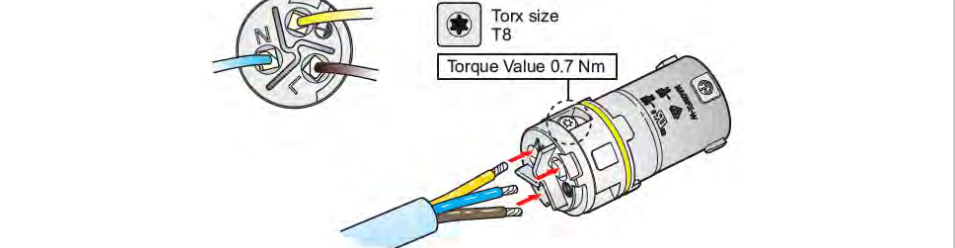

Wiring Instructions

Wiring instructions for the Neutrik PowerCon True1 are as follows. Note that all mains wiring should be carried out by a competent, trained technician. If a suitable technician is not available Martin Audio would recommend purchasing one of the range of pre-made mains cables available as optional accessories. These feature the PowerCon True1 connector on a flexible cable of either 2.15m (part number ASF12024) or 5m (part number ASF12023) in length and are terminated in a 16A male Ceeform connector. Both cables are rated to IP67.

Approval based:	VDE EN 60320	UL UL 498 / C22.2 No. 182.3
Rating:	250 V ac / 16A	250 V ac / 20 A
Cable Type:	H05VV-F3G 1.0mm ² , Length max. 2m H05VV-F3G 1.5 – 2.5mm ² H07RN-F3G 1.5mm ²	SJTOW, SJOOW 3 x 12 AWG
Strain Relief:	White Chuck	White Chuck
Cable O.D.:	6.0 – 12.0 mm	6.0 – 12.0 mm
A: Prepare cable as shown.		
B: Place chuck over cable.		
C: Wire the connector Using a Torx T8 driver, the fixing screws should be tightened to a torque value of 0.7Nm.		
Live	Brown 	Black 
Neutral	Blue 	White 
Ground	Green/yellow 	Green 

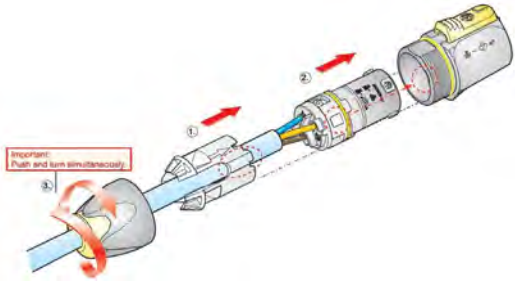
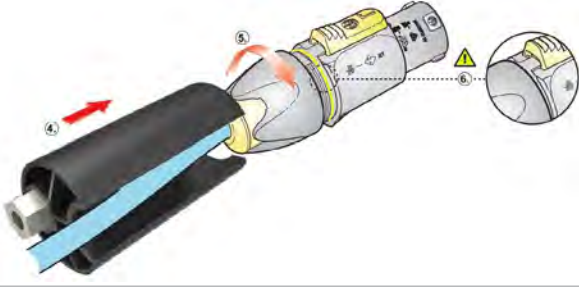
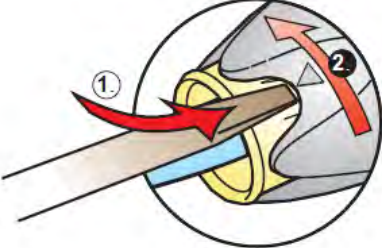
<p>D: Assemble the connector</p> <p>Slide the chuck onto insert and then both into the housing.</p> <p>Note: Align the chuck by positioning the nose into the keyway.</p>	
<p>E: Tighten the cable clamp</p> <p>Slide the cable clamp up the cable and tighten. To wire the connector to IP65, the cable clamp needs to be tightened to a torque value of 2.0Nm using the Neutrik tool no. HTAC with a 13mm spanner.</p>	
<p>Disassembly</p> <p>Press a small flat-blade screwdriver into the cable clamp bush by the ▲ symbol, continue to push the screwdriver in whilst unscrewing the clamp.</p>	

Analogue Audio

Analogue audio is available on a 3-pin XLR socket with a parallel male XLR socket to enable easy “daisy-chain” wiring looping from one speaker to the next. Analogue inputs should be connected with a good quality 3-pin male XLR wired to good quality twin screened cable. This is particularly important if the input cable run is long (e.g., from the FOH position to stage). Good quality cable will minimise losses. The link outputs should use a similarly high quality female XLR. The line driver at the signal source must be able to drive the combined load of all SXP subwoofers or CDD-LIVE being linked. Wiring is the industry standard for balanced connections:

PIN	CONNECTION
1	Ground or shield
2	Signal ‘hot’ (+)
3	Signal ‘cold’ (-)

Network

Two network ports are available to control the subwoofer via Martin Audio’s VU-NET software and to route Dante audio to each sub. The two Ethernet ports are available on Neutrik Ethercon connectors which can be used either with a compatible mating connector or directly with a CAT5 cable with RJ45 connectors. The connections are routed to a two-port switch which enables daisy-chain Ethernet/Dante connections of up to 8 cabinets. Alternatively, a star network configuration can be adopted using any Gigabit enabled Ethernet router connecting individual Ethernet cables to each cabinet. Note that the ports can carry both Dante and TCP/IP data simultaneously so a Dante network can be set up with control over all CDD-LIVE cabinets via VU-NET.

Note that you must use a network system that supports DHCP to connect multiple CDD-LIVE products, a simple Ethernet switch will NOT work unless the entire system is configured for static IP, you will need an Ethernet router or a device connected to an Ethernet switch which will support DHCP to assign IP addresses to all devices on the network. You can connect directly from a PC Ethernet port to ONE CDD-LIVE cabinet which will self-assign an IP address in the same range as the PC. This takes around one minute and after that it will be possible to connect to the cabinet via VU-NET. You CANNOT daisy-chain more CDD-LIVE cabinets in this configuration. It can only be used with a single cabinet so its use is limited to simple checks or firmware updates.

Dante is realised using the Ultimo board, this does not support primary and secondary connections but redundancy is possible using an analogue audio feed simultaneously with a Dante network. The input will automatically select Dante if a signal is present however it will automatically switch to the analogue feed if the Dante signal is lost. The Ethernet ports have standard LED indicators to show operation. The green LEDs show that the port is operational and should illuminate as soon as a connection is made to or from an Ethernet port from any other port. The yellow LEDs flash to show data speed. The Dante LED will illuminate when a Dante feed is present.

Preset Operation

SXP118 can be fully configured using VU-NET on an Ethernet network. Alternatively plug-and-play operation is available using factory presets selected using the preset button on the connector panel.



Preset 1 - SXP118 used in conjunction with CDD-LIVE12 or CDD-LIVE15:



Preset 2 - SXP118 used in conjunction with CDD-LIVE8:

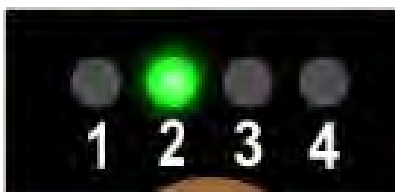

Preset 3 - SXP118 used in conjunction with CDD-LIVE12 or CDD-LIVE15 in cardioid (rear facing) mode:

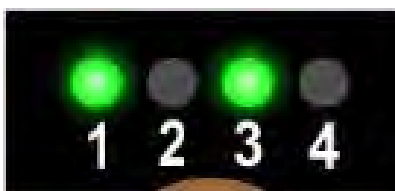

Preset 4 - SXP118 used in conjunction with CDD-LIVE8 in cardioid (rear facing) mode:

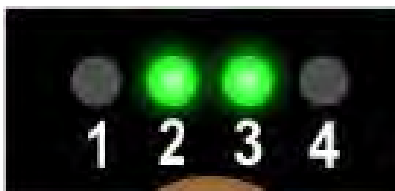

Note that the selected preset is retained after powering down the SXP118. The same preset will still be selected when you next power-up the cabinet.

When a system is connected to VU-NET via the Ethernet ports the preset LEDs will be extinguished to show that the system settings may have been changed. To restore the preset once VU-NET is disconnected press the preset button until it has cycled round to the preset you require. Any changes made in VU-NET will then be overwritten with the factory setting.

Meter Mode

An additional feature is meter mode which is selected by pressing and holding the preset select button for two seconds. In this mode the LEDs which normally indicate which preset has been selected, become an input level bar graph to show level applied to the speaker. To return to normal preset selection, press and hold again for two seconds.

Dante

SXP118 can be fed via a Dante feed on an Ethernet network. Hundreds of Dante-enabled products are available, enabling you to mix devices from multiple manufacturers.

Dante does away with heavy, expensive analogue or multicore cabling, replacing it with low-cost, easily-available CAT5e, CAT6, or fibre optic cable for a simple, lightweight and economical solution. Dante integrates media and control for your entire system over a single, standard IP network.

Dante systems can easily scale from a simple pairing of a console to a computer, to large capacity networks running thousands of audio channels. Because Dante uses logical routes instead of physical point-to-point connections, the network can be expanded and reconfigured at any time with just a few mouse clicks.

Since audio is transmitted digitally, you don't have to worry about the common analogue challenges of interference from other electrical equipment, crosstalk between cables, or signal degradation over long cable runs.

Signal routing and system configuration with Dante Controller can be fast, simple. Setting up a Dante network is typically just a matter of plugging devices into an Ethernet switch and connecting a computer to the network. All Dante devices are automatically discovered and displayed in Dante Controller.

With Dante Controller you can easily edit device names and channel labels, control sample rates, and set device latencies. Once the network is configured, the computer running Dante Controller can be removed from the network, and reconnected only if changes are required or system monitoring is desired. Signal routing and other system settings are stored safely in the Dante devices themselves, so they are automatically restored if a device is power-cycled.

Real-time information about the health of your network is essential for a proper understanding of its performance. Audinate's diagnostic tools provide visibility into the network health status through features such as device latency monitoring, active clock health monitoring, packet error reporting and bandwidth usage statistics.

VU-NET

SXP118 may be controlled using Martin Audio's VU-NET software application. VU-NET is Martin Audio's proprietary application for control of monitoring of network controlled powered products. Introduced as the control platform for MLA, MLA Compact and MLA Mini, a number of products have been added to Martin Audio's portfolio that can be incorporated into a single project and configured using VU-NET. SXP118 subwoofers in combination with the CDD-LIVE Series are fully integrated into the platform.

For further information and instruction on VU-NET and to download the application and user guide, please visit www.martin-audio.com/software.

Flying SXP118

Eyebolts

The SXP118 features M10 inserts to allow flown applications using eyebolts. M10 eyebolts suitable for flown systems are available as accessories from Martin Audio. These are cast steel shouldered eye bolts specifically designed and rated for flown applications. If alternative eyebolts are used these must be cast or machined products stamped with their SWL. Formed steel non-shouldered eyebolts commonly available from DIY stores should not be used under any circumstances as they are not sufficiently load-rated for flown applications.

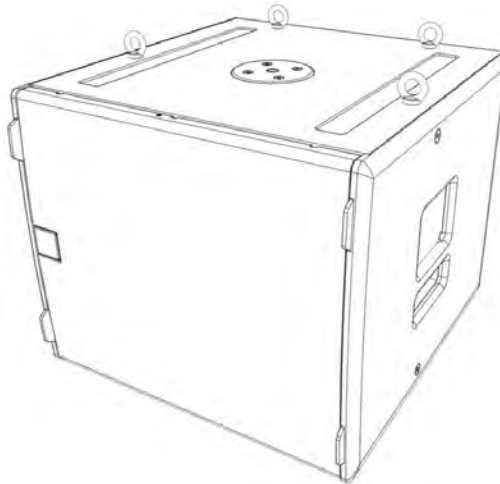

Remove the M10 counter-sunk screws and screw the eyebolts into position. We would recommend four eyebolts and an additional eyebolt as a redundant safety bond. This should be attached to a different point than the other bolts to support the cabinet in the event of the other points failing.

Eyebolts should be connected to a suitably rated fixing point such as a girder clamp or a heavy duty fixing such as a sleeve anchor or similar. They can be linked using suitably rated steel rope or chain and shackles.

Safety note: Flying heavy equipment in public spaces is dangerous and should only be undertaken by suitably qualified and experienced personnel using adequately rated equipment for the task.

Transit Covers

The SXP118 features an optional transit cover to protect the cabinet when used in portable applications.

To ensure that the insert is accurately located, four locating brackets are utilised. These are built into the cabinet in the four corners and may be fitted in the parked position as standard. To use with the transit cover it is necessary to reverse the four brackets.

Remove the top and bottom safety screws from the grille. Insert a flat blade screwdriver into the slots of the grille and carefully easing the grille out of the slot.

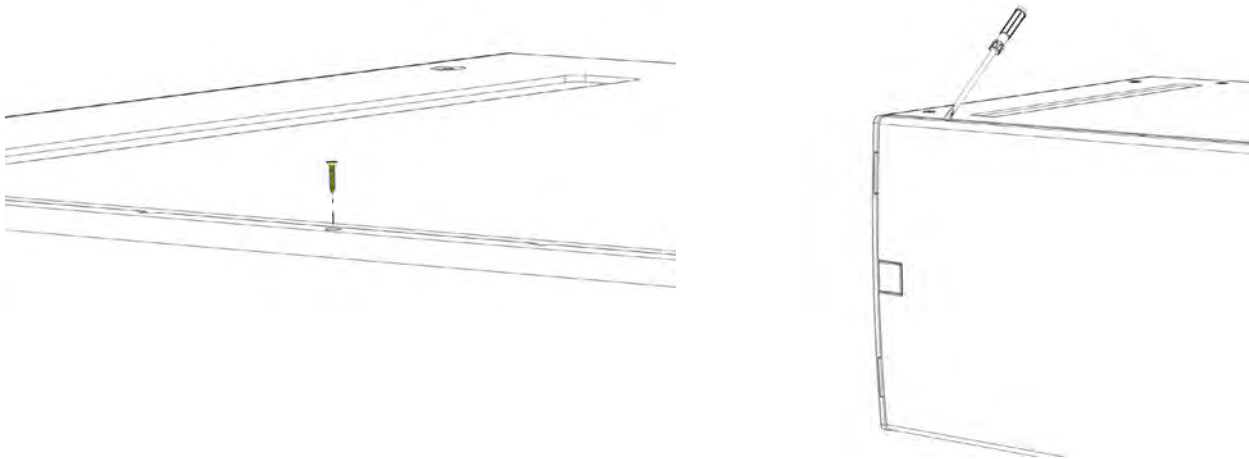

Remove the screws from the grille support on the side of the cabinet and remove the grille support.

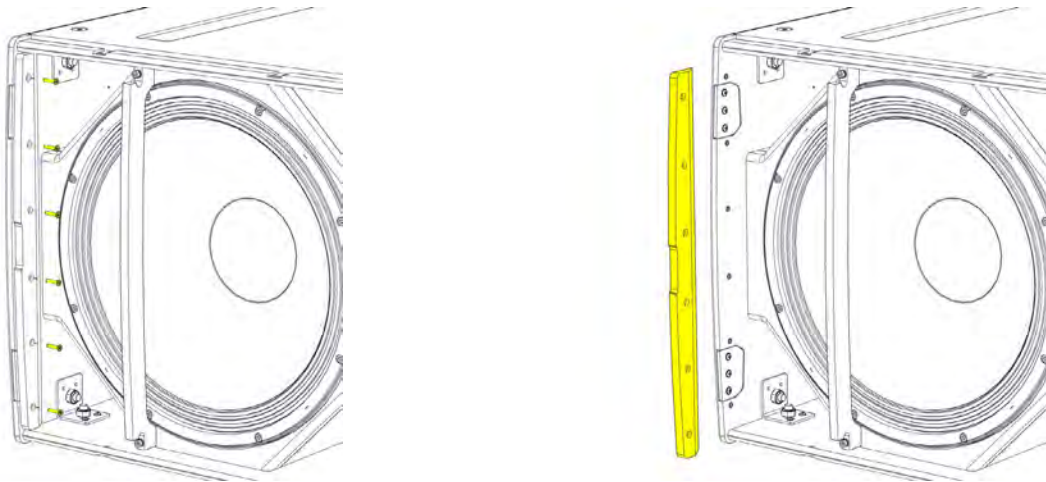

Remove the three screws from the bracket.

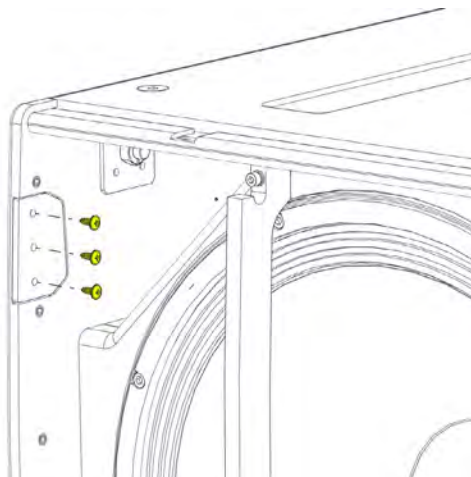

Rotate the bracket 180°. The bracket will now extend approximately 20mm from the front edge of the cabinet, ensure that the slope on the bracket follows the curved contour of the cabinet.

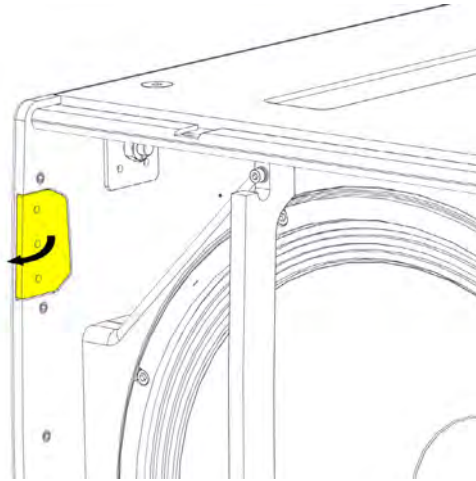

Screw the bracket back in place and repeat for the other three brackets.

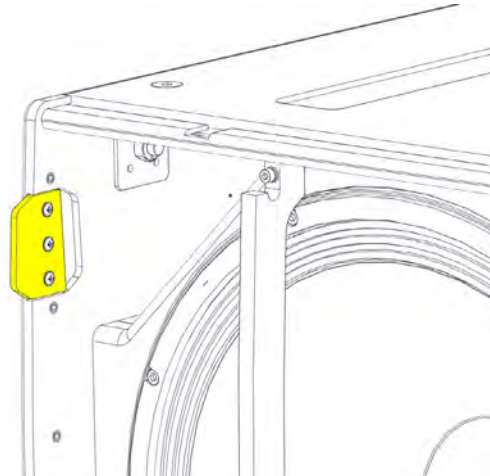
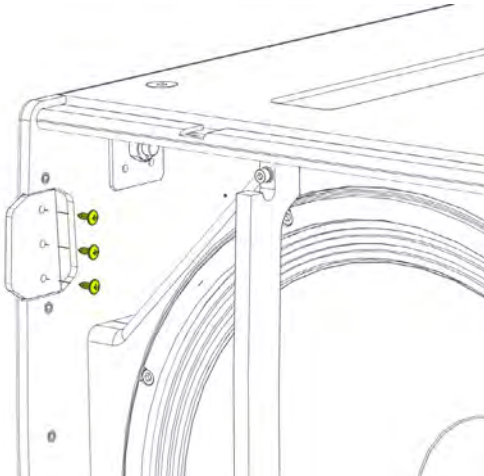

Replace the grill supports and fit the grille making sure the safety screws are used.

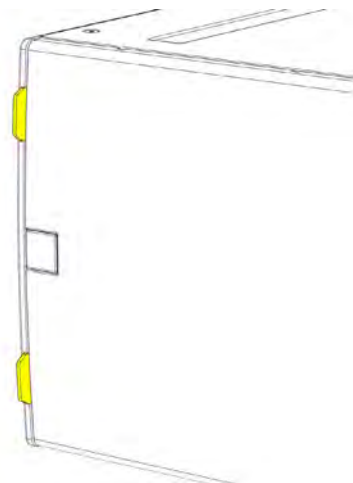
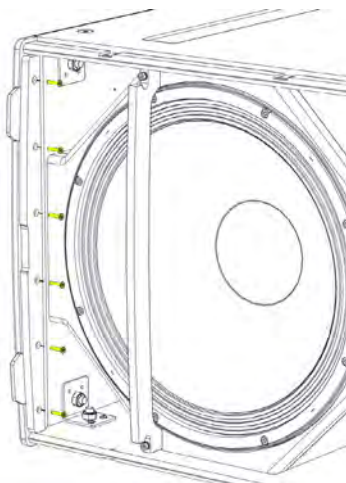

Castors

To fit the castors, remove the M8 counter-sunk screws from the rear of the enclosure.

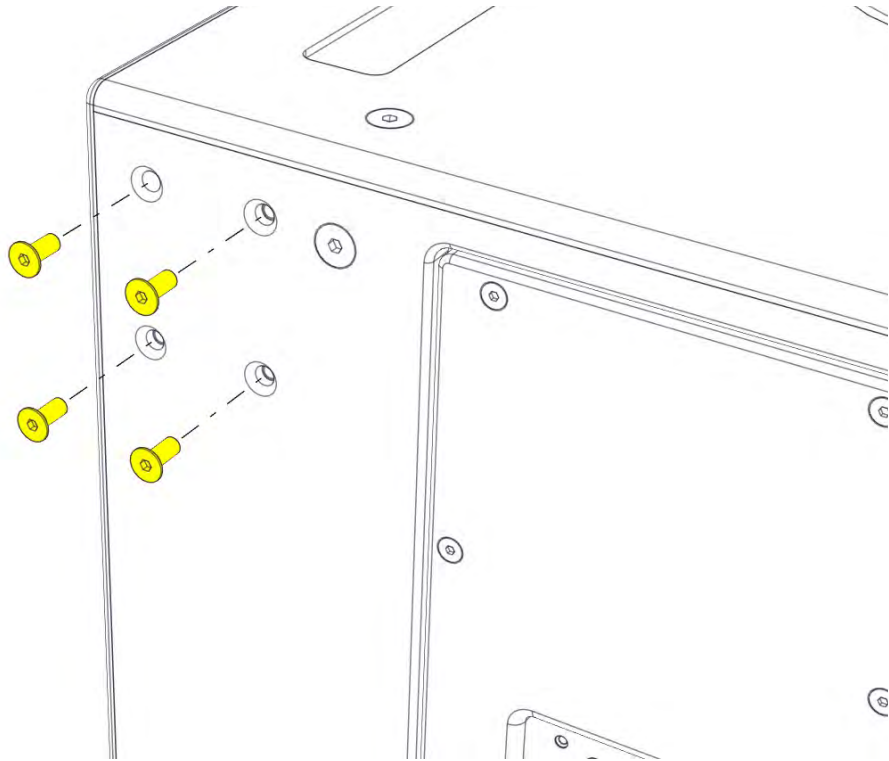

Position each castor over the insets and screw into place using the fixings supplied in the kit.

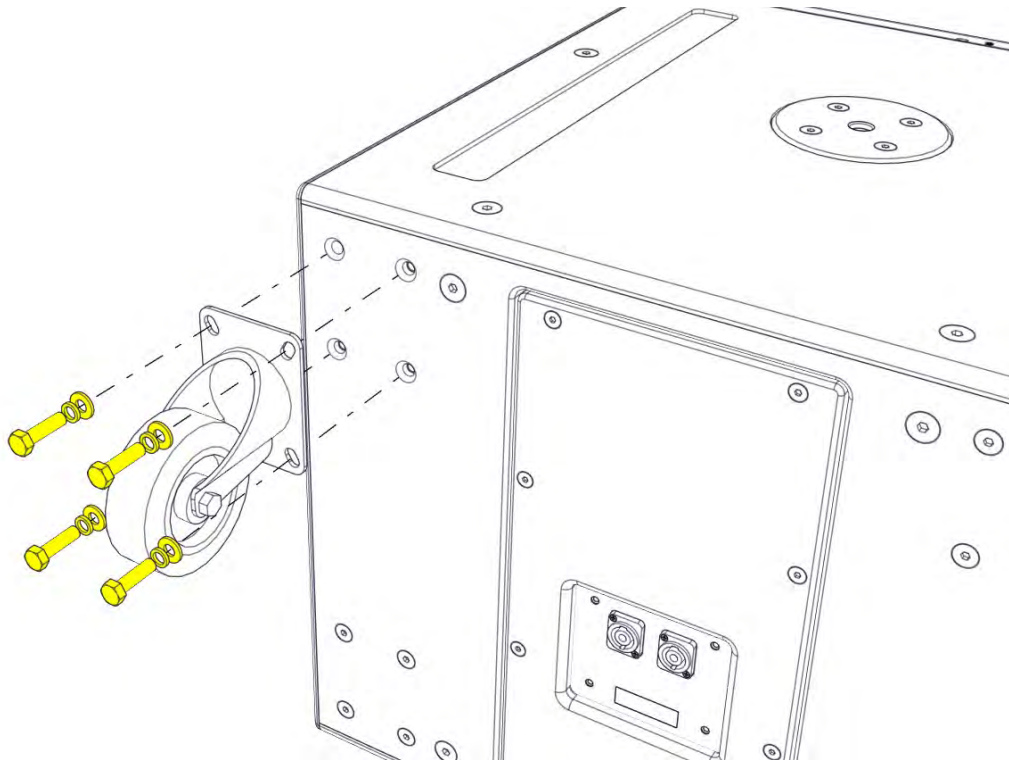



SXP118



Weather Kit

The SXP118 has an optional rain cowl available which fixes to the back of the cabinet to protect the amplifier module from inclement weather when used outdoors. This must be factory fitted so should be ordered at the time of purchase or returned to Martin Audio or a Martin Audio approved service agent.

Specifications

TYPE	Compact, direct radiating powered subwoofer
FREQUENCY RESPONSE (1)	47Hz-150Hz ± 3dB, -10dB @ 41Hz
DRIVER	18" (460mm)/4" (100mm) voice coil, long excursion, ferrite magnet, waterproof cone
INPUT SENSITIVITY	-20dBu for 100dB SPL (CDD-LIVE12/15 pre-set) -13dBu for 100dB SPL (CDD-LIVE8 pre-set)
MAXIMUM SPL (4)	132dB continuous / 135dB peak
DISPERSION	Omnidirectional / Cardioid (paired using cardioid preset)
CROSSOVER	Active. Presets for CDD-LIVE 8, 12 & 15 mono-pole or cardioid (paired)
CONNECTORS	Female XLR input, male XLR link output, Dante Audio Neutrik® Ethercon
ANALOGUE INPUT IMPEDANCE	20 kΩ balanced to ground
MAXIMUM ANALOGUE INPUT LEVEL	24.6 Vpp (+21dBu), over voltage protected
INTERNAL PROCESSING	Multi-channel DSP, programmable via TCP/IP using VU-Net software PEQ/shelving filters, Up to 48dB/Oct LPF, Up to 200ms input delay Pre-set selection via rear panel switch
NETWORK CONNECTORS	2xNeutrik® Ethercon
NETWORK PROTOCOL	TCP/IP and UDP/IP
AMPLIFIER MODULE	2 channel switch-mode, class D, Bridged Tied
OUTPUT POWER	2000W (Peak), 1000W (Continuous)
AVERAGE EFFICIENCY	89%
COOLING	External fan
MAXIMUM AMBIENT TEMPERATURE	40°C (104°F) for full output
POWER SUPPLY	Switch mode, fixed frequency with PFC
AC INPUT OPERATING RANGE	85 – 265V ~ AC, 50 - 60Hz
POWER FACTOR	> 0.98
NOMINAL POWER CONSUMPTION	550W
MAINS CONNECTOR	Neutrik® Powercon True1
ENCLOSURE	Extensively braced multi-laminate birch plywood
FINISH	Textured black PU Coating
PROTECTIVE GRILLE	Black perforated Zintec
FITTINGS	Two skids on base, matching channels on top. 2 x bar handles M20 top-mounted thread plate for pole mounting 16 x M10 mounting points, 4 x fittings for optional transit cover
IP RATING	IP24 factory option available
DIMENSIONS (INCL SKIDS)	(W) 600mm x (H) 509mm x (D) 632mm (760mm including castors) (W) 23.62in x (H) 20.04in x (D) 24.86in (29.9in including castors)
WEIGHT	46.5kg (103lbs). 50Kg (110lbs) with castors

Notes

- (1) Measured on-axis in half (2pi) space at 2 metres, then referred to 1 metre.
- (2) AES Standard ANSI S4.26-1984.
- (3) Measured in half (2pi) space at 2 metres with 1 watt input, using band limited pink noise, then referred to 1 metre.
- (4) Measured in half (2pi) space at 2 metres using band limited pink noise, then referred to 1 metre.
- (5) Measured on-axis in open (4pi) space at 2 metres, then referred to 1 metre.
- (6) Measured in open (4pi) space at 2 metres with 1 watt input, using band limited pink noise, then referred to 1 metre.
- (7) Measured in open (4pi) space at 2 metres using band limited pink noise, then referred to 1 metre.
- (8) Measured in open (4pi) space at 2 metres with 2.83V input, using band limited pink noise, then referred to 1 metre.
- (9) Calculated at 1 metre.
- (10) Measured in half (2pi) space at 2 metres with 2.83V input, using band limited pink noise, then referred to 1 metre.

Technical Drawing

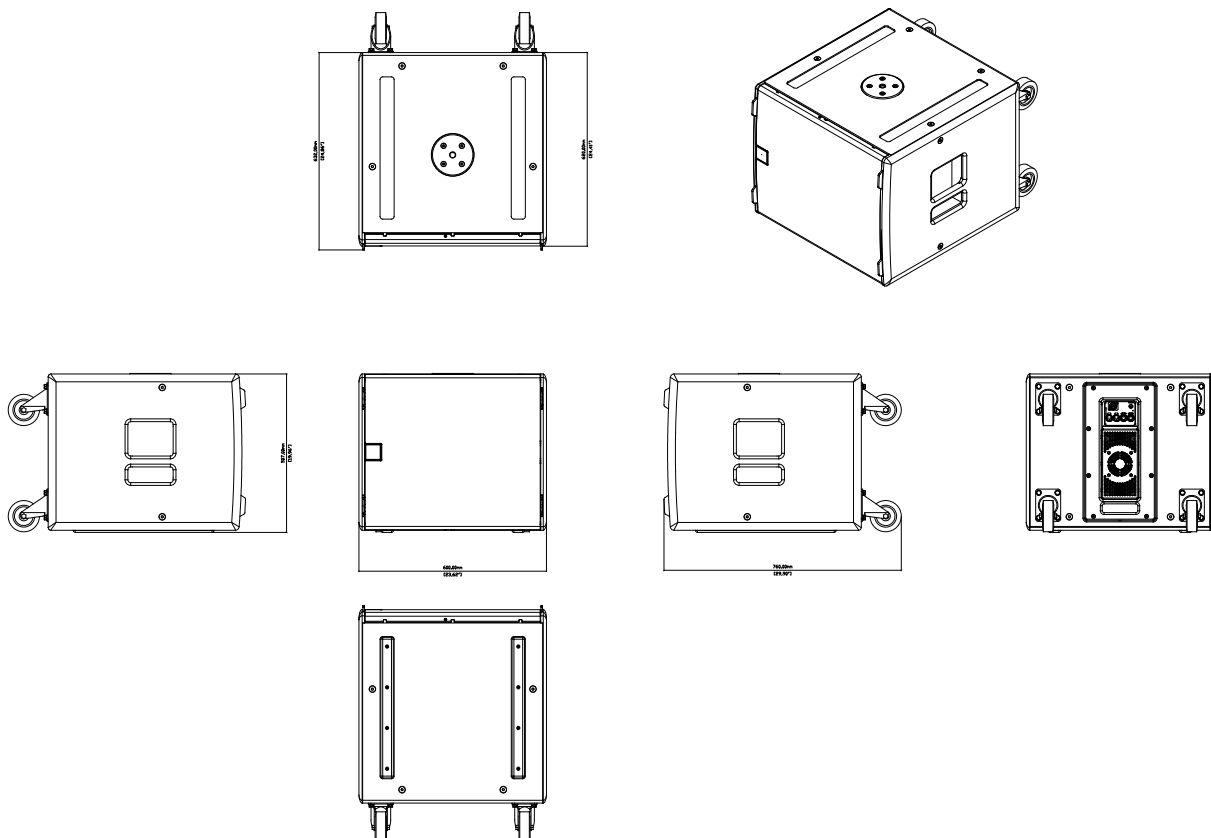

Castors are shown for illustration only and are not included as standard.

SXP218



Introduction

The SXP218 achieves the ultimate in subwoofer performance for the most demanding professional applications – delivering very high output levels and superb transient performance with minimal distortion. With an operating range of 35Hz-150Hz ± 3dB, it houses dual 18” long-excursion (460mm)/4” (100mm) voice coil drivers with water-resistant cones and triple roll surrounds. The design of the 18” drivers maximises output while minimising power compression and distortion, and the eight reflex ports have a large frontal area to reduce turbulent air noise at very high levels. With a prodigious maximum SPL capability of 143dB peak at 1 metre, the SXP218 is the ideal subwoofer for touring sound reinforcement, theatre and portable live sound applications — as well as premium installations — that require low frequency augmentation with low distortion at very high output levels.

A self-powered system, the SXP218 incorporates a Class D amplifier, DSP and Dante™ digital audio networking — simplifying set-up, enhancing control and eliminating amplifier racks. The onboard amplifier delivers a total of 4000W peak output to the drivers, and its switched-mode power supply auto-ranges to global mains voltages from 100 to 240V 50/60Hz. DSP functions — including parametric EQ, delay, muting, gain and preset selection — can be controlled over Ethernet from a PC or Windows® tablet via intuitive VU-NET™ proprietary software.

Accessories

M10 eyebolts	HTKCT06
Install flying frame	SX218GRIDi
Flying kit	SX218FKIT
Transit cover	CDDLTC218
Castor kit	WHEELKIT
Wind-up pole	ASF20071
Weather kit	CDDLK118/218

Connections

The SXP218 is a powered subwoofer and shares its connections with the CDD-LIVE range. There are three types of connection on each sub, consisting of mains, analogue XLR and Network Ethercon.







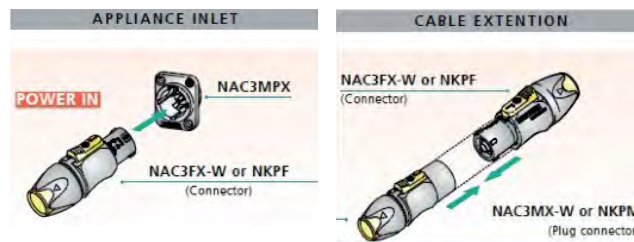

Mains

The mains inlet is a Neutrik® PowerCon True1 socket and a mating connector is supplied with each CDD-LIVE speaker. The True1 is the latest version of Neutrik's PowerCon range and is a small, light, rugged, inexpensive latching mains connector rated for use up to 240V at 16A. It is rated with a breaking capacity according to IEC60320 and VDE0625 meaning that it can be connected and disconnected without first turning off the power feed. This has the advantage of being very convenient but also makes a power switch unnecessary as it is easy to turn the speaker off by activating the latch and turning the connector anticlockwise which will disconnect the power whilst leaving the plug in place in the socket so it can be quickly rotated clockwise to restore the power connection when required.

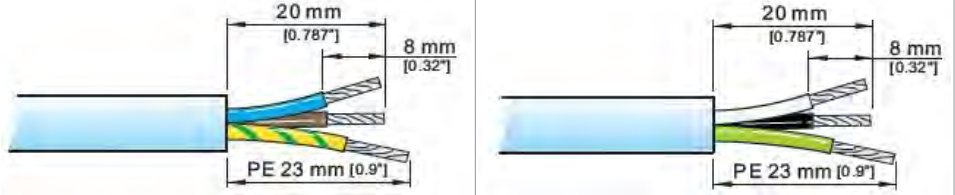
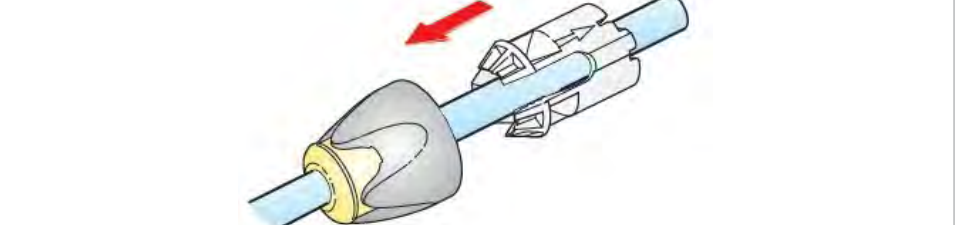
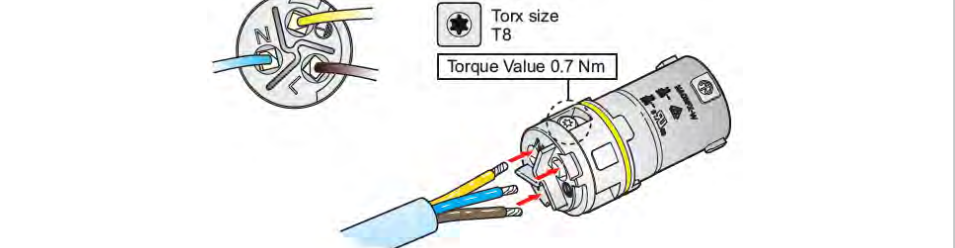

Wiring Instructions

Wiring instructions for the Neutrik PowerCon True1 are as follows. Note that all mains wiring should be carried out by a competent, trained technician. If a suitable technician is not available Martin Audio would recommend purchasing one of the range of pre-made mains cables available as optional accessories. These feature the PowerCon True1 connector on a flexible cable of either 2.15m (part number ASF12024) or 5m (part number ASF12023) in length and are terminated in a 16A male Ceeform connector. Both cables are rated to IP67.

Approval based:	VDE EN 60320	UL UL 498 / C22.2 No. 182.3
Rating:	250 V ac / 16A	250 V ac / 20 A
Cable Type:	H05VV-F3G 1.0mm ² , Length max. 2m H05VV-F3G 1.5 – 2.5mm ² H07RN-F3G 1.5mm ²	SJTOW, SJOOW 3 x 12 AWG
Strain Relief:	White Chuck	White Chuck
Cable O.D.:	6.0 – 12.0 mm	6.0 – 12.0 mm
A: Prepare cable as shown.		
B: Place chuck over cable.		
C: Wire the connector Using a Torx T8 driver, the fixing screws should be tightened to a torque value of 0.7Nm.		
Live Neutral Ground	Brown  Blue  Green/yellow 	Black  White  Green 

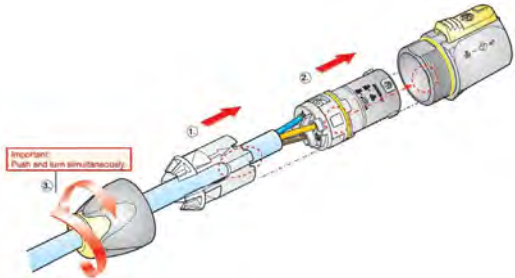
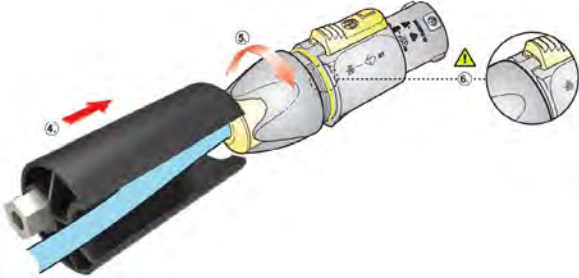
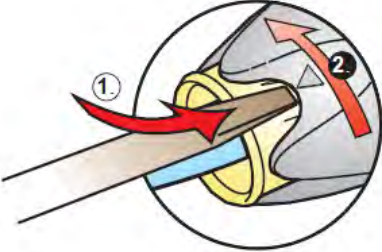
<p>D: Assemble the connector</p> <p>Slide the chuck onto insert and then both into the housing.</p> <p>Note: Align the chuck by positioning the nose into the keyway.</p>	
<p>E: Tighten the cable clamp</p> <p>Slide the cable clamp up the cable and tighten. To wire the connector to IP65, the cable clamp needs to be tightened to a torque value of 2.0Nm using the Neutrik tool no. HTAC with a 13mm spanner.</p>	
<p>Disassembly</p> <p>Press a small flat-blade screwdriver into the cable clamp bush by the ▲ symbol, continue to push the screwdriver in whilst unscrewing the clamp.</p>	

Analogue Audio

Analogue audio is available on a 3-pin XLR socket with a parallel male XLR socket to enable easy “daisy-chain” wiring looping from one speaker to the next. Analogue inputs should be connected with a good quality 3-pin male XLR wired to good quality twin screened cable. This is particularly important if the input cable run is long (e.g., from the FOH position to stage). Good quality cable will minimise losses. The link outputs should use a similarly high quality female XLR. The line driver at the signal source must be able to drive the combined load of all SXP subwoofers or CDD-LIVE being linked. Wiring is the industry standard for balanced connections:

PIN	CONNECTION
1	Ground or shield
2	Signal ‘hot’ (+)
3	Signal ‘cold’ (-)

Network

Two network ports are available to control the subwoofer via Martin Audio’s VU-NET software and to route Dante audio to each sub. The two Ethernet ports are available on Neutrik Ethercon connectors which can be used either with a compatible mating connector or directly with a CAT5 cable with RJ45 connectors. The connections are routed to a two-port switch which enables daisy-chain Ethernet/Dante connections of up to 8 cabinets. Alternatively, a star network configuration can be adopted using any Gigabit enabled Ethernet router connecting individual Ethernet cables to each cabinet. Note that the ports can carry both Dante and TCP/IP data simultaneously so a Dante network can be set up with control over all CDD-LIVE cabinets via VU-NET.

Note that you must use a network system that supports DHCP to connect multiple CDD-LIVE products, a simple Ethernet switch will NOT work unless the entire system is configured for static IP, you will need an Ethernet router or a device connected to an Ethernet switch which will support DHCP to assign IP addresses to all devices on the network. You can connect directly from a PC Ethernet port to ONE CDD-LIVE cabinet which will self-assign an IP address in the same range as the PC. This takes around one minute and after that it will be possible to connect to the cabinet via VU-NET. You CANNOT daisy-chain more CDD-LIVE cabinets in this configuration. It can only be used with a single cabinet so its use is limited to simple checks or firmware updates.

Dante is realised using the Ultimo board, this does not support primary and secondary connections but redundancy is possible using an analogue audio feed simultaneously with a Dante network. The input will automatically select Dante if a signal is present however it will automatically switch to the analogue feed if the Dante signal is lost. The Ethernet ports have standard LED indicators to show operation. The green LEDs show that the port is operational and should illuminate as soon as a connection is made to or from an Ethernet port from any other port. The yellow LEDs flash to show data speed. The Dante LED will illuminate when a Dante feed is present.

Preset Operation

SXP218 can be fully configured using VU-NET on an Ethernet network. Alternatively plug-and-play operation is available using factory presets selected using the preset button on the connector panel.



Preset 1 - SXP218 used in conjunction with CDD-LIVE12 or CDD-LIVE15:



Preset 2 - SXP218 used in conjunction with CDD-LIVE8:



Preset 3 - SXP218 used in conjunction with CDD-LIVE12 or CDD-LIVE15 in cardioid (rear facing) mode:



Preset 4 - SXP218 used in conjunction with CDD-LIVE8 in cardioid (rear facing) mode:



Note that the selected preset is retained after powering down the SXP218. The same preset will still be selected when you next power-up the cabinet.

When a system is connected to VU-NET via the Ethernet ports the preset LEDs will be extinguished to show that the system settings may have been changed. To restore the preset once VU-NET is disconnected press the preset button until it has cycled round to the preset you require. Any changes made in VU-NET will then be overwritten with the factory setting.

Meter Mode

An additional feature is meter mode which is selected by pressing and holding the preset select button for two seconds. In this mode the LEDs which normally indicate which preset has been selected, become an input level bar graph to show level applied to the speaker. To return to normal preset selection, press and hold again for two seconds.

Dante

SXP218 can be fed via a Dante feed on an Ethernet network. Hundreds of Dante-enabled products are available, enabling you to mix devices from multiple manufacturers.

Dante does away with heavy, expensive analogue or multicore cabling, replacing it with low-cost, easily-available CAT5e, CAT6, or fibre optic cable for a simple, lightweight and economical solution. Dante integrates media and control for your entire system over a single, standard IP network.

Dante systems can easily scale from a simple pairing of a console to a computer, to large capacity networks running thousands of audio channels. Because Dante uses logical routes instead of physical point-to-point connections, the network can be expanded and reconfigured at any time with just a few mouse clicks.

Since audio is transmitted digitally, you don't have to worry about the common analogue challenges of interference from other electrical equipment, crosstalk between cables, or signal degradation over long cable runs.

Signal routing and system configuration with Dante Controller can be fast, simple. Setting up a Dante network is typically just a matter of plugging devices into an Ethernet switch and connecting a computer to the network. All Dante devices are automatically discovered and displayed in Dante Controller.

With Dante Controller you can easily edit device names and channel labels, control sample rates, and set device latencies. Once the network is configured, the computer running Dante Controller can be removed from the network, and reconnected only if changes are required or system monitoring is desired. Signal routing and other system settings are stored safely in the Dante devices themselves, so they are automatically restored if a device is power-cycled.

Real-time information about the health of your network is essential for a proper understanding of its performance. Audinate's diagnostic tools provide visibility into the network health status through features such as device latency monitoring, active clock health monitoring, packet error reporting and bandwidth usage statistics.

VU-NET

SXP218 may be controlled using Martin Audio's VU-NET software application. VU-NET is Martin Audio's proprietary application for control of monitoring of network controlled powered products. Introduced as the control platform for MLA, MLA Compact and MLA Mini, a number of products have been added to Martin Audio's portfolio that can be incorporated into a single project and configured using VU-NET. SXP218 subwoofers in combination with the CDD-LIVE Series are fully integrated into the platform.

For further information and instruction on VU-NET and to download the application and user guide, please visit www.martin-audio.com/software.

Flying SXP218

Eyebolts

The SXP218 features M10 inserts to allow flown applications using eyebolts. M10 eyebolts suitable for flown systems are available as accessories from Martin Audio. These are cast steel shouldered eye bolts specifically designed and rated for flown applications. If alternative eyebolts are used these must be cast or machined products stamped with their SWL. Formed steel non-shouldered eyebolts commonly available from DIY stores should not be used under any circumstances as they are not sufficiently load-rated for flown applications.

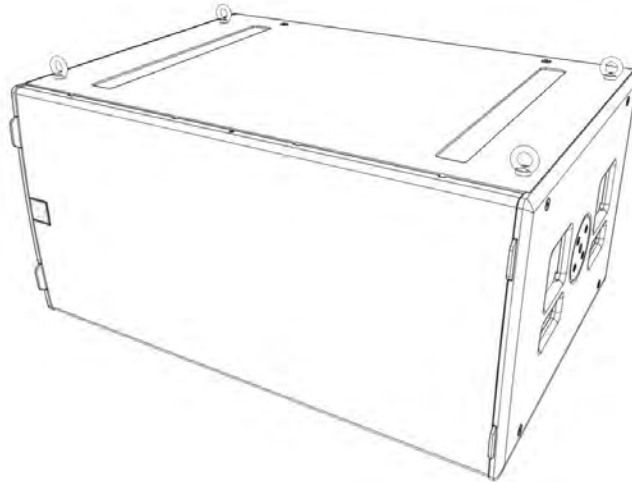

Remove the M10 counter-sunk screws and screw the eyebolts into position. We would recommend four eyebolts and an additional eyebolt as a redundant safety bond. This should be attached to a different point than the other bolts to support the cabinet in the event of the other points failing.

Eyebolts should be connected to a suitably rated fixing point such as a girder clamp or a heavy duty fixing such as a sleeve anchor or similar. They can be linked using suitably rated steel rope or chain and shackles.

Safety note: Flying heavy equipment in public spaces is dangerous and should only be undertaken by suitably qualified and experienced personnel using adequately rated equipment for the task.

Flying Frame and Flying Kit

A flying system is available for the SXP218 for installation applications. This uses the SX218FKIT and SX218GRIDi.

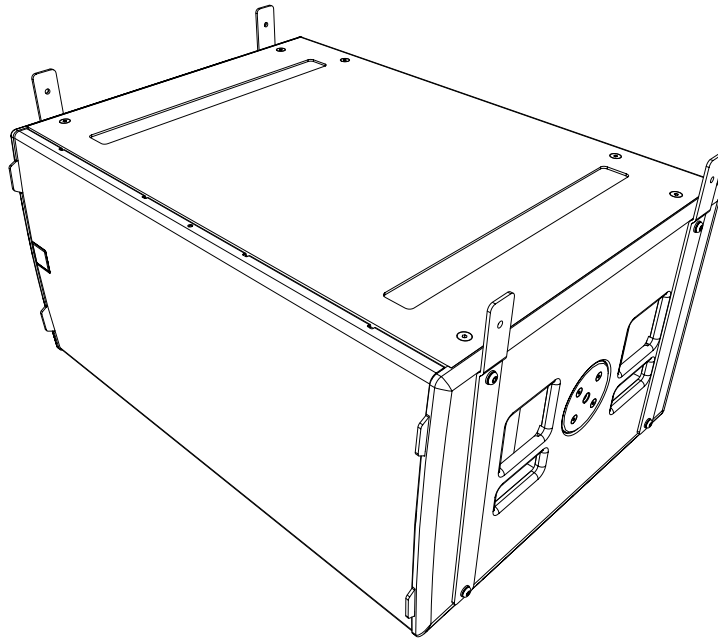

Fit the SX218FKIT flying kit to each cabinet. There are four steel brackets in each kit and these attach vertically, two on each side of the subwoofer. Remove all four M10 bolts in the inserts on the sides of the cabinet.

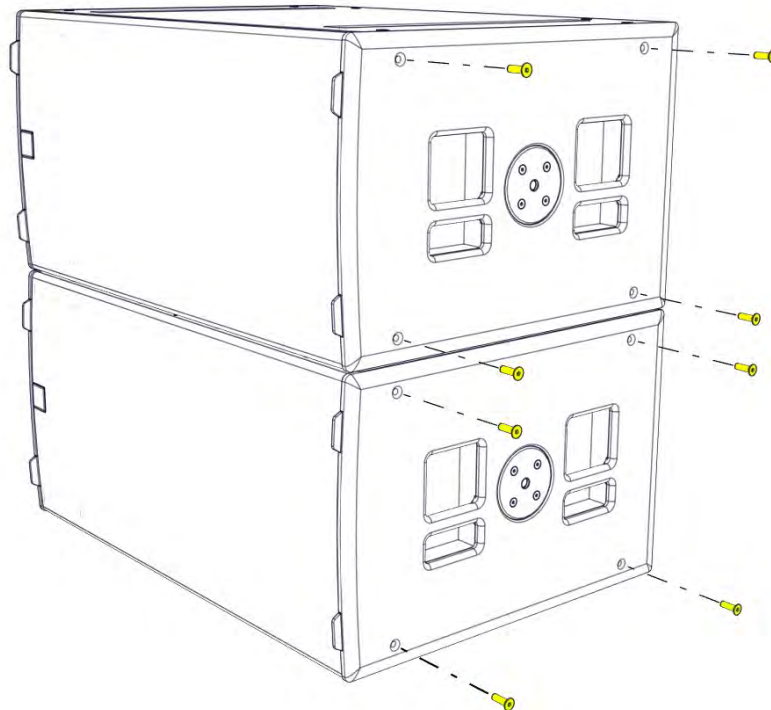

Attach the brackets, two on each with the “dog-leg” in the bracket at the top angled outwards using two M10 bolts and washers in each bracket.

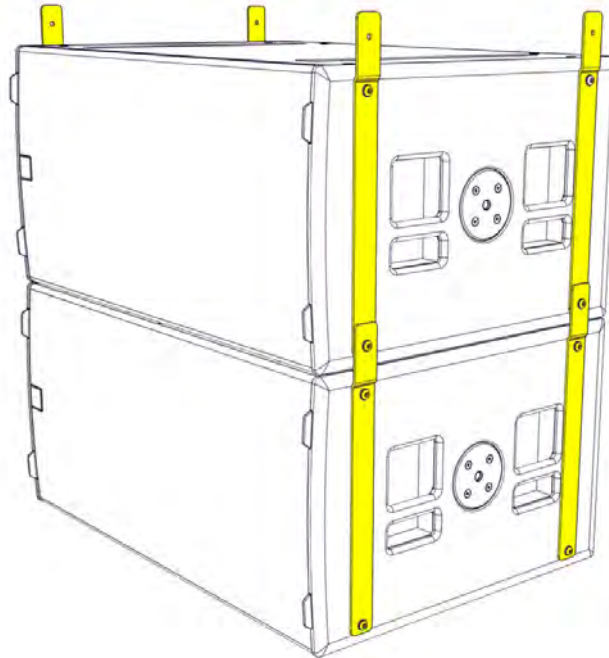
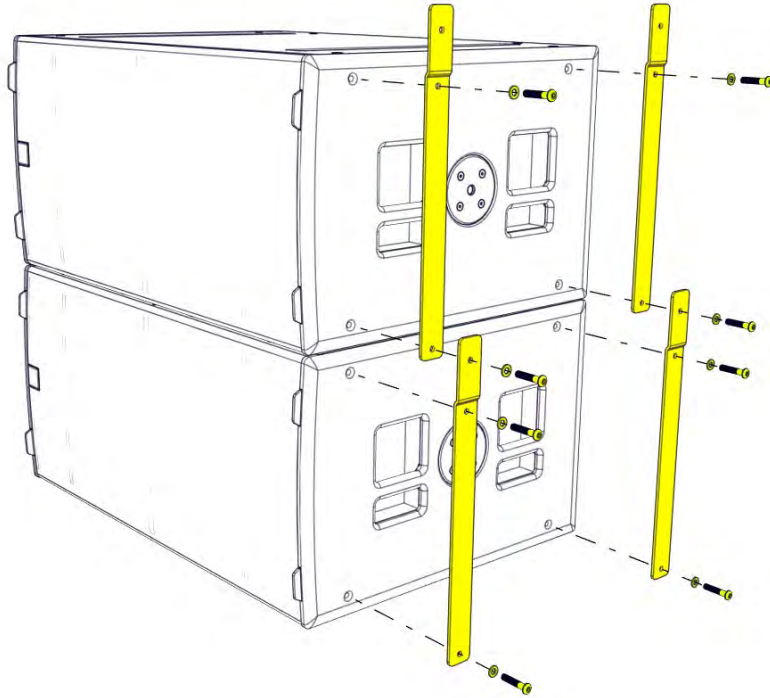

Next the SX218GRiDi should be attached to the two chain hoists that are being used to suspend the sub array. One point is required at the front and a second at the back. The hooks on the hoists can be attached using the two 3.25T Shackles supplied with the grid. Fly the grid out to a height so you can move the SXP218 under it then lower the grid to line up the fixing holes on the grid with those on the brackets on the sub.

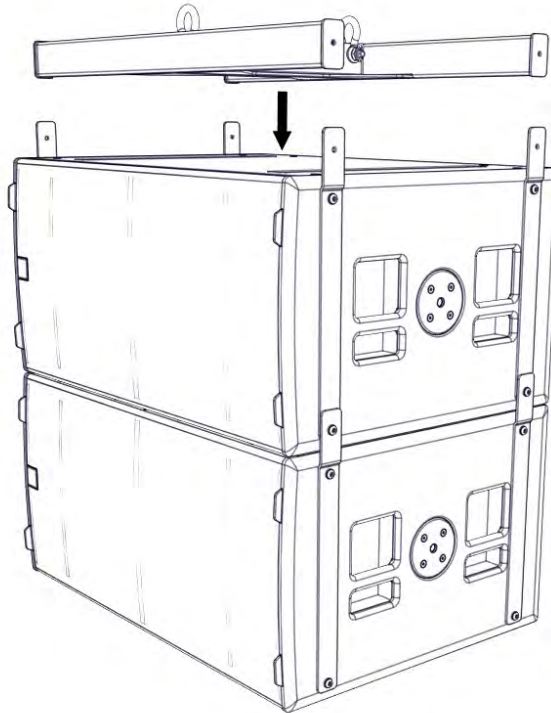

Join using the four M10 x 50 button head screws and washers supplied with the grid assembly. The sub can now be safely flown to the desired height.

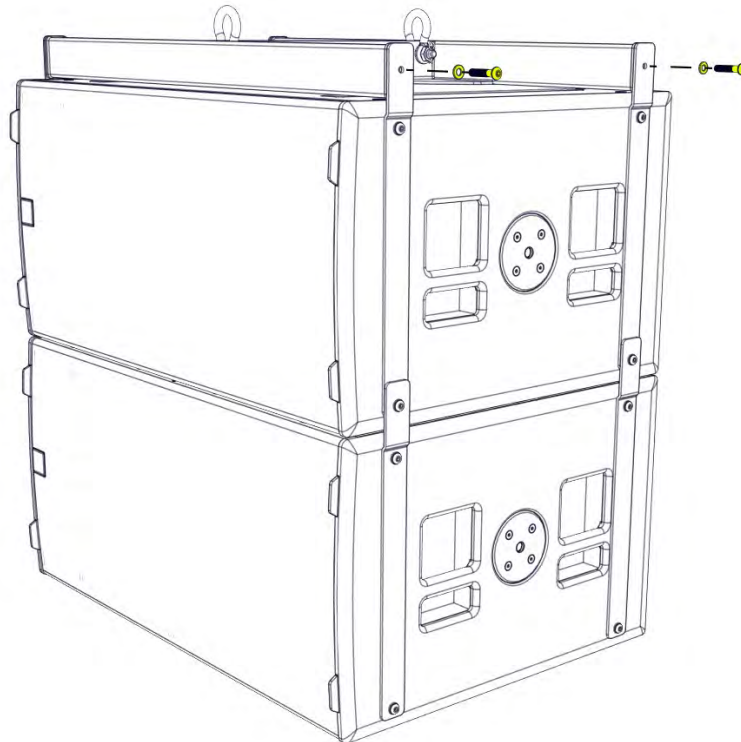

A maximum of six SXP218 subwoofers can be flown using this method.

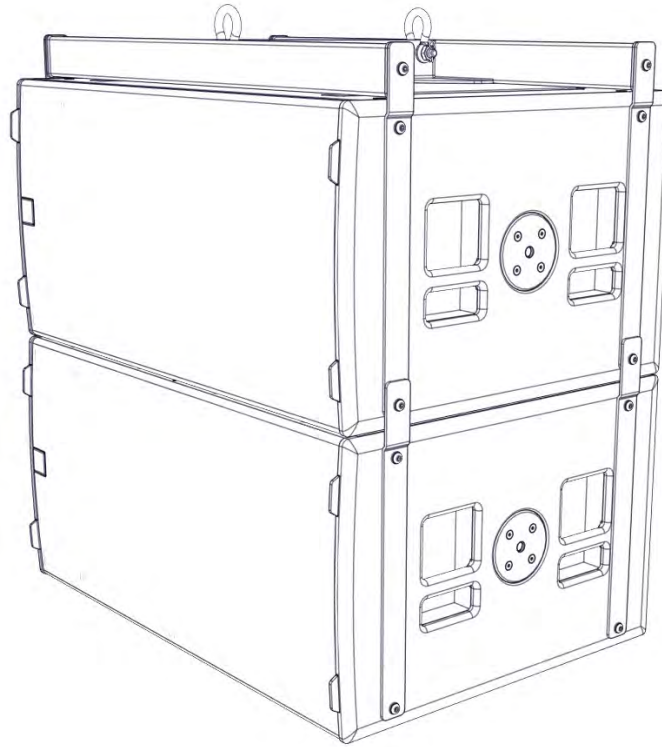

Transit Covers

The SXP218 features an optional transit cover to protect the cabinet when used in portable applications.

To ensure that the insert is accurately located, four locating brackets are utilised. These are built into the cabinet in the four corners and may be fitted in the parked position as standard. To use with the transit cover it is necessary to reverse the four brackets.

Remove the top and bottom safety screws from the grille. Insert a flat blade screwdriver into the slots of the grille and carefully easing the grille out of the slot.

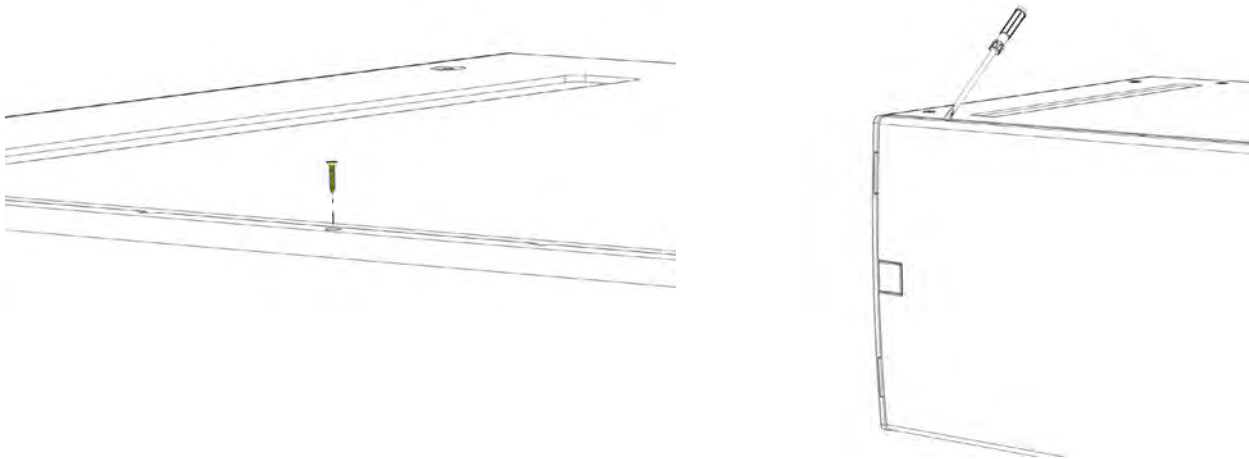

Remove the screws from the grille support on the side of the cabinet and remove the grille support.

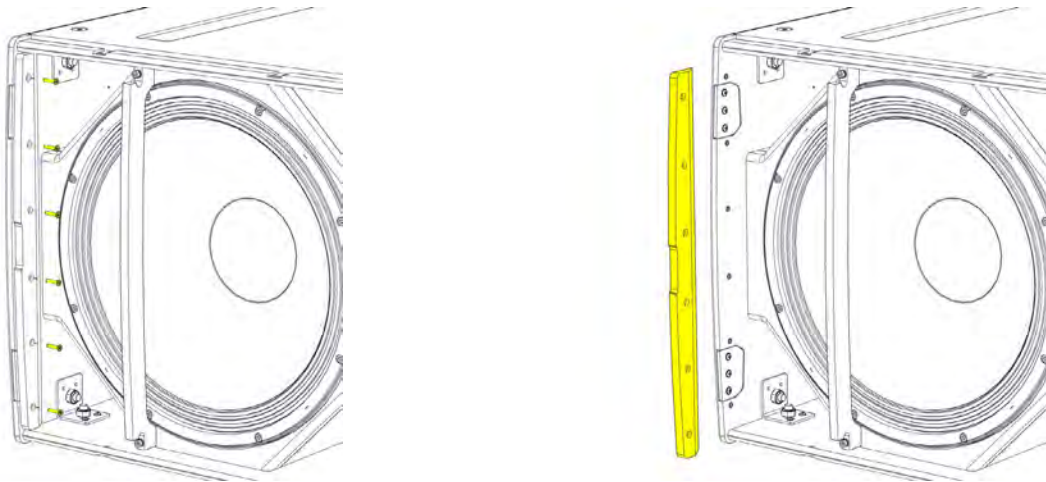

Remove the three screws from the bracket.

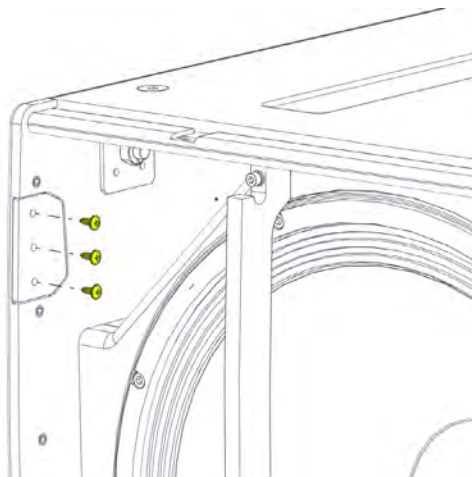

Rotate the bracket 180°. The bracket will now extend approximately 20mm from the front edge of the cabinet, ensure that the slope on the bracket follows the curved contour of the cabinet.

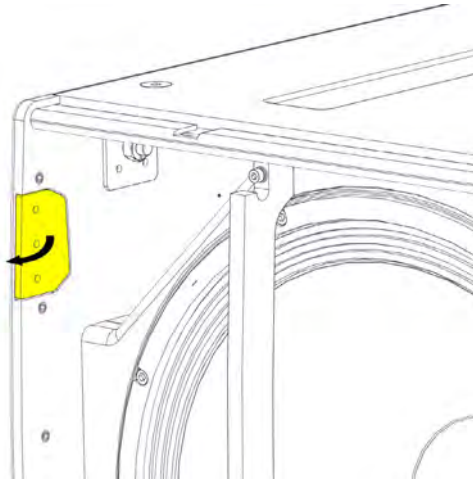

Screw the bracket back in place and repeat for the other three brackets.

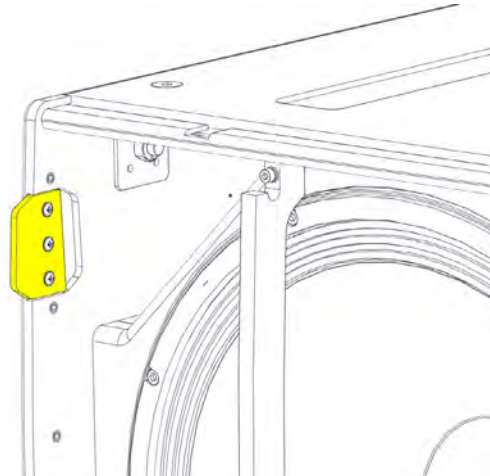
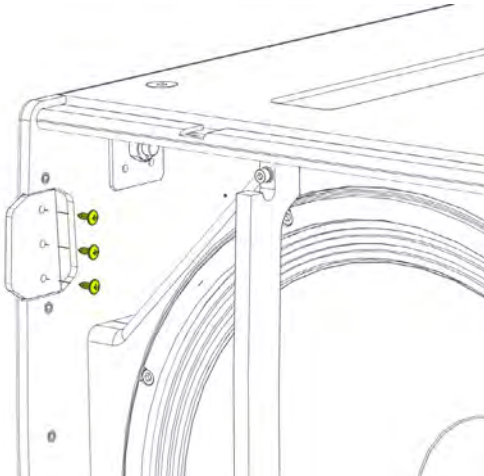

Replace the grill supports and fit the grille making sure the safety screws are used.

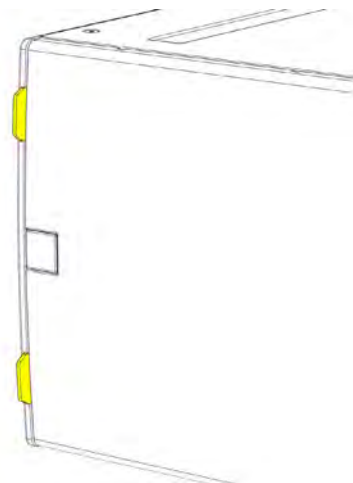
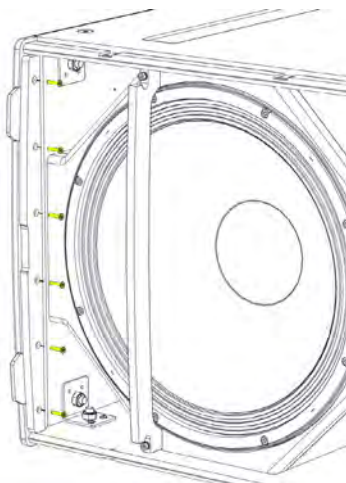

Castors

To fit the castors, remove the M8 counter-sunk screws from the rear of the enclosure.

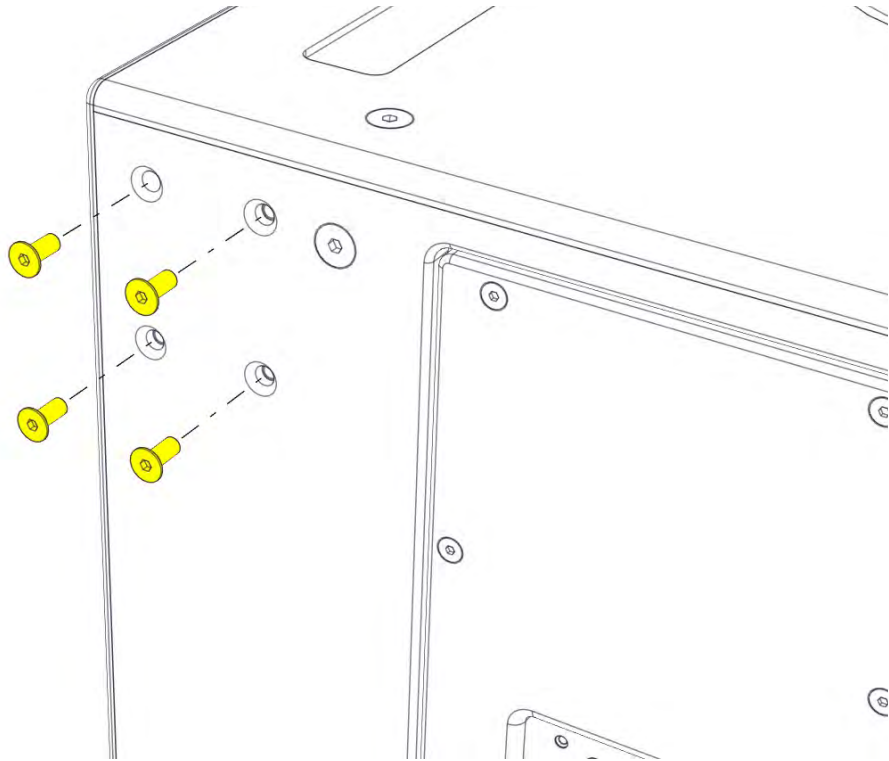

Position each castor over the insets and screw into place using the fixings supplied in the kit.

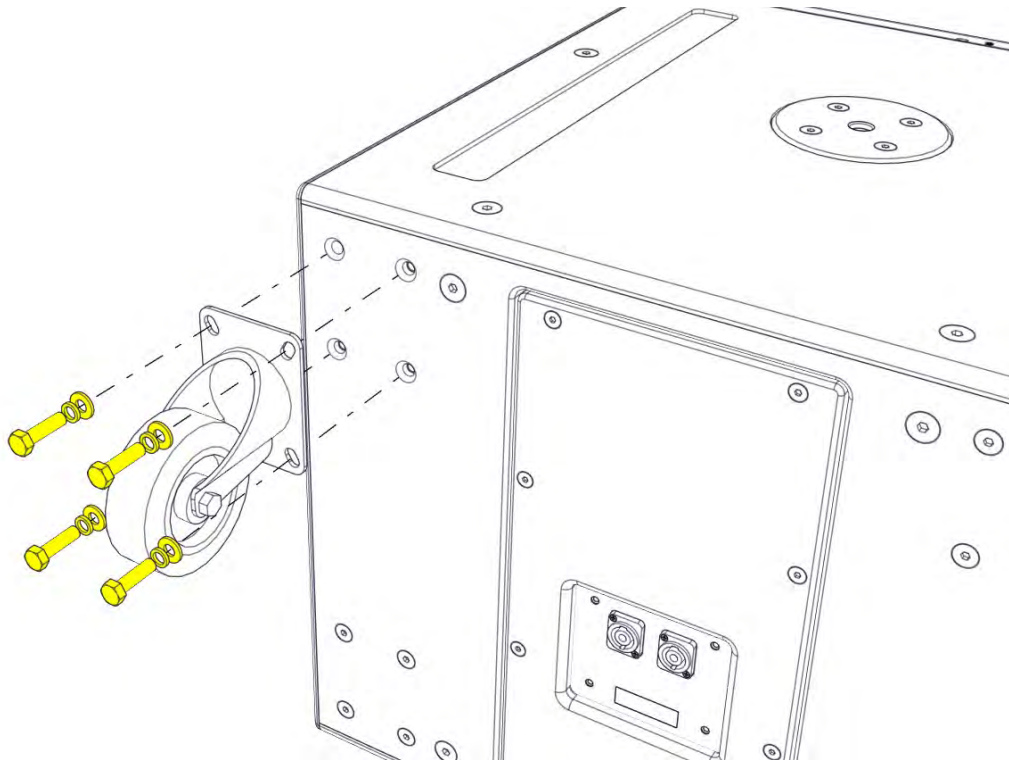



SXP218



Weather Kit

The SXP218 has an optional rain cowl available which fixes to the back of the cabinet to protect the amplifier module from inclement weather when used outdoors. This must be factory fitted so should be ordered at the time of purchase or returned to Martin Audio or a Martin Audio approved service agent.

Specifications

TYPE	Dual-driver, direct radiating powered subwoofer
FREQUENCY RESPONSE (1)	35Hz-150Hz ± 3dB, -10dB @ 30Hz
DRIVER	2 x 18" (460mm)/4" (100mm) voice coil, long excursion, ferrite magnet, waterproof cone
INPUT SENSITIVITY	-20dBu for 100dB SPL (CDD-LIVE12/15 pre-set), -13dBu for 100dB SPL (CDD-LIVE8 pre-set)
MAXIMUM SPL (4)	140dB continuous / 143dB peak
DISPERSION	Omnidirectional / Cardioid (paired using cardioid preset)
CROSSOVER	Active. Presets for CDD-LIVE 8, 12 & 15 mono-pole or cardioid (paired)
CONNECTORS	Female XLR input, male XLR link output, Dante Audio Neutrik® Ethercon
ANALOGUE INPUT IMPEDANCE	20 kΩ balanced to ground
MAXIMUM ANALOGUE INPUT LEVEL	24.6 Vpp (+21dBu), over voltage protected
INTERNAL PROCESSING	Multi-channel DSP, programmable via TCP/IP using VU-Net software PEQ/shelving filters, Up to 48dB/Oct LPF, Up to 200ms input delay Pre-set selection via rear panel switch
NETWORK CONNECTORS	2xNeutrik® Ethercon
NETWORK PROTOCOL	TCP/IP and UDP/IP
AMPLIFIER MODULE	2 channel switch-mode, class D, Bridged Tied Load
OUTPUT POWER	4000W (Peak), 2000W (Continuous)
AVERAGE EFFICIENCY	89%
COOLING	External fan
MAXIMUM AMBIENT TEMPERATURE	40°C (104°F) for full output
POWER SUPPLY	Switch mode, fixed frequency with PFC
AC INPUT OPERATING RANGE	85 – 265V ~ AC, 50 - 60Hz
POWER FACTOR	> 0.98
NOMINAL POWER CONSUMPTION	550W
MAINS CONNECTOR	Neutrik® Powercon True1
ENCLOSURE	Extensively braced multi-laminate birch plywood
FINISH	Textured black PU Coating
PROTECTIVE GRILLE	Black perforated Zintec
FITTINGS	Two skids on base, matching channels on top. 2 x bar handles. M20 top-mounted thread plate for pole mounting 24 x M10 mounting points, 4 x fittings for optional transit cover
IP RATING	IP24 factory option available
DIMENSIONS (INCL SKIDS)	(W) 1085mm x (H) 537mm x (D) 792mm (920mm including castors) (W) 42.72in x (H) 21.13in x (D) 31.16in (36.2in including castors)
WEIGHT	101.5kg (224lbs). 105Kg (231lbs) with castors

Notes

- (1) Measured on-axis in half (2pi) space at 2 metres, then referred to 1 metre.
- (2) AES Standard ANSI S4.26-1984.
- (3) Measured in half (2pi) space at 2 metres with 1 watt input, using band limited pink noise, then referred to 1 metre.
- (4) Measured in half (2pi) space at 2 metres using band limited pink noise, then referred to 1 metre.
- (5) Measured on-axis in open (4pi) space at 2 metres, then referred to 1 metre.
- (6) Measured in open (4pi) space at 2 metres with 1 watt input, using band limited pink noise, then referred to 1 metre.
- (7) Measured in open (4pi) space at 2 metres using band limited pink noise, then referred to 1 metre.
- (8) Measured in open (4pi) space at 2 metres with 2.83V input, using band limited pink noise, then referred to 1 metre.
- (9) Calculated at 1 metre.
- (10) Measured in half (2pi) space at 2 metres with 2.83V input, using band limited pink noise, then referred to 1 metre.

Technical Drawing

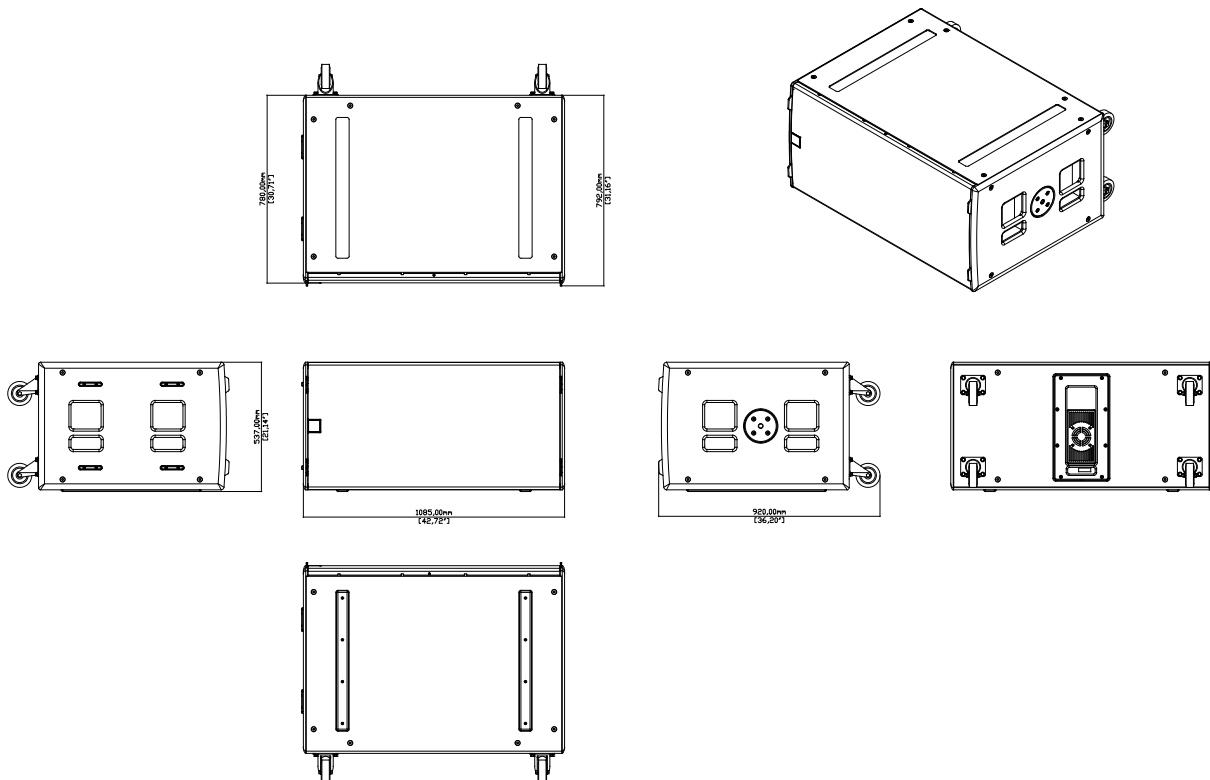

Castors are shown for illustration only and are not included as standard.

Warranty

SX110, SX210, SX112, SX212, SXF115, SXC118, SX118, SXC118, SXCF118, SX218, SXH218, SXHF218

Martin Audio SX subwoofers are warranted against manufacturing defects in materials or craftsmanship over a period of 5 years from the date of original purchase.

During the warranty period Martin Audio will, at its discretion, either repair or replace products which prove to be defective provided that the product is returned in its original packaging, shipping prepaid, to an authorised Martin Audio service agent or distributor.

Martin Audio cannot be held responsible for defects caused by unauthorised modifications, improper use, negligence, exposure to inclement weather conditions, act of God or accident, or any use of this product that is not in accordance with the instructions provided by Martin Audio.

Martin Audio is not liable for consequential damages.

This warranty is exclusive and no other warranty is expressed or implied. This warranty does not affect your statutory rights.

SXP118, SXP218

Martin Audio SXP subwoofers are warranted against manufacturing defects in materials or craftsmanship over a period of 5 years from the date of original purchase.

Martin Audio SXP amplifier modules are warranted against manufacturing defects in materials or craftsmanship over a period of 2 years from the date of original purchase.

During the warranty period Martin Audio will, at its discretion, either repair or replace products which prove to be defective provided that the product is returned in its original packaging, shipping prepaid, to an authorised Martin Audio service agent or distributor.

Martin Audio cannot be held responsible for defects caused by unauthorised modifications, improper use, negligence, exposure to inclement weather conditions, act of God or accident, or any use of this product that is not in accordance with the instructions provided by Martin Audio.

Martin Audio is not liable for consequential damages.

This warranty is exclusive and no other warranty is expressed or implied. This warranty does not affect your statutory rights.

Martin Audio Limited

Century Point

Halifax Road

Cressex Business Park

High Wycombe

Buckinghamshire

HP12 3SL

England

FOR SALES ENQUIRIES:

UK

Telephone: +44 (0)1494 535312

E-mail: info@martin-audio.com

NORTH AMERICA

Telephone: 323-381-5310

www.martin-audio.com

All information is Copyright © 2020 Martin Audio Ltd.

Martin Audio, the Martin Audio logo and Hybrid are registered trademarks of Martin Audio Ltd. in the United Kingdom, United States and other countries; all other Martin Audio trademarks are the property of Martin Audio Ltd.

