

THE SOUND OF THINGS TO COME

 **CDD**TM **LIVE** ⚡



Unite Your Audience
The Martin Audio Experience



CDD-LIVE! THE SOUND OF THINGS TO COME

Until now, most self-powered portable loudspeakers have been underpowered, light-duty systems or very high-end systems out of reach of many users. Now, with the multi-purpose CDD-LIVE! Series, Martin Audio brings everything rental companies, system integrators and musicians require from a self-powered loudspeaker into sharp focus.

Comprising three full-range models and when complimented by SXP subwoofers, CDD-LIVE! covers practically all professional stand-alone and distributed applications — from sound reinforcement and monitoring for live bands, DJ's and corporate events, to installations in dance clubs, ballrooms, theatres and performing arts centres.

Combining the 'point-source' benefits of coaxial designs with the consistent coverage of Differential Dispersion technology, CDD-LIVE! full-range systems project sound evenly front-to-back while exhibiting wide horizontal coverage close to the speaker — delivering ultimate fidelity and impact to all corners of the audience.

Onboard Class D amplification, DSP and Dante™ Digital Audio networking assure simplicity of stage set-up and efficient installation, while tour-grade enclosures and comprehensive mounting options — including pole mount, wall brackets, yokes and rigging inserts — provide maximum flexibility in deployment.

With sonic consistency across the range, a rectangular coverage footprint and a multitude of deployment options, CDD-LIVE! is truly versatile — the professional self-powered solution that means business.

Interested in a demo? Register your details here:

<https://martin-audio.com/support/advice>



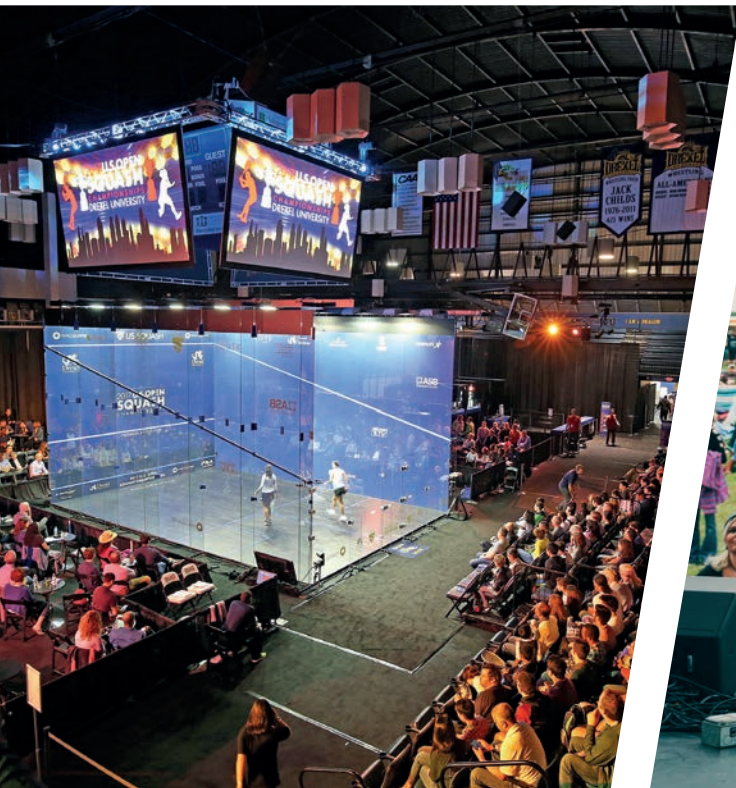



ADVANTAGES FOR RENTAL COMPANIES

- Quick ROI
- Coverage and consistency
- Simplicity of stage set up

ADVANTAGES FOR SYSTEM INTEGRATORS

- More competitive tenders
- Coverage and consistency
- Simplicity of installation



FEATURES

- Multi-purpose, professional self-powered systems
- Coaxial Differential Dispersion technology achieves 'point source' performance and optimum coverage footprint across the audience plane
- Fully-integrated systems with onboard Class D amplification and DSP under proprietary VU-NET software control
- Dante™ Digital Audio networking
- Global mains operation with PFC (Power Factor Correction)
- Full-range models feature compact, multi-angle enclosures for vertical and horizontal orientation and stage monitor use
- Drivers can be rotated for vertical or horizontal operation by removing screw-free perforated steel grilles
- Tour-grade plywood enclosures finished in a rugged polyurea coating
- Usable in indoor and temporary outdoor environments
- IP24 environmental rating (with optional rain cowl)
- Comprehensive mounting options including pole mount, wall brackets, yokes and rigging inserts

APPLICATIONS

- Live sound reinforcement
- Theatre sound
- Corporate AV events
- Fixed installations in concert halls, ballrooms and HoW
- Stage monitors and sidefills
- Premium dancefloor
- Bars and clubs

COAXIAL DIFFERENTIAL DISPERSION™: THE BEST OF BOTH WORLDS

CDD-LIVE! combines the 'point-source' benefits of coaxial designs with the consistent coverage of Differential Dispersion technology. All CDD-LIVE! full-range models feature Martin Audio's unique, patented Coaxial Differential Dispersion™ technology to deliver perfect sound to every member of the audience.



• CDD-LIVE 12 Driver

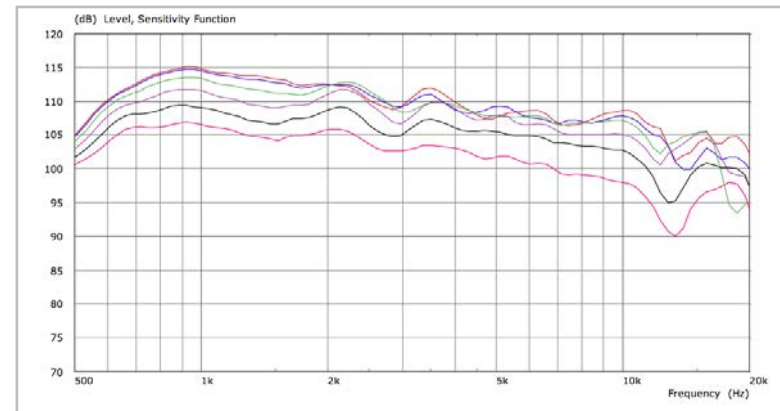

- 0/10/20/30/40/50 degree off-axis measurements of CDD-LIVE 15 (wide-axis). Constant beamwidth maintained up to 20kHz.

THE COAXIAL ADVANTAGE

Non-coaxial systems can suffer from uneven frequency response in the crossover region because the outputs of the LF and HF sections interfere with each other, causing variations off-axis, depending on the listening position. This is especially true close to the loudspeaker. In contrast, coaxial systems can achieve 'point-source' summation of the LF and HF sections at all positions off-axis, even close-up. This is one reason that coaxial devices are often used for nearfield applications such as studio monitoring.

Significantly, until now one disadvantage of conventional coaxial devices has been high frequency beaming, where the high frequency dispersion reduces as the frequency increases. This is primarily because conventional coaxial devices channel high frequencies through a narrow tube in the pole-piece of the magnet system. CDD-LIVE! coaxial devices overcome this by incorporating an innovative static waveguide that merges seamlessly with the unique cone shape — maintaining the dispersion pattern out to very high frequencies.

THE DIFFERENTIAL DISPERSION™ ADVANTAGE

A Differential Dispersion horn has a 3D trapezoid dispersion pattern which covers a room more evenly than a system with a conventional, fixed-dispersion $X^\circ \times Y^\circ$ type horn. With a conventional $X^\circ \times Y^\circ$ horn, the speaker is usually placed just above head height and aimed towards the centre of the audience. This produces an imperfect coverage pattern which misses out some areas — particularly side areas close to the loudspeaker. In contrast, a CDD-LIVE! Coaxial Differential Dispersion system produces a rectangular coverage pattern to reach all corners of the audience, and wide horizontal coverage is

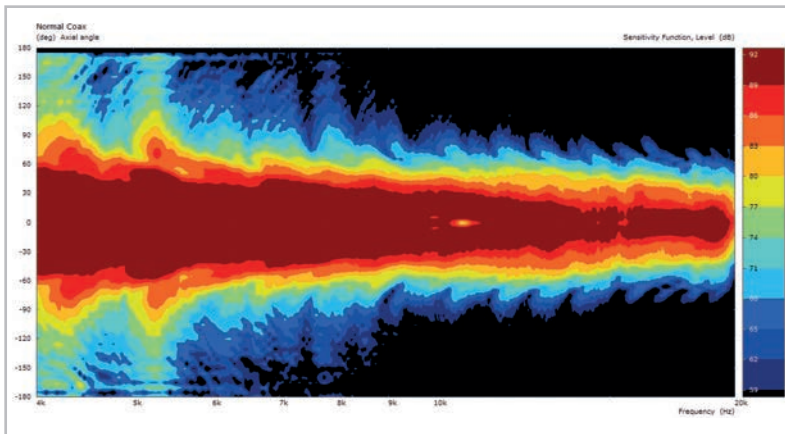

• Conventional coaxial beamwidth

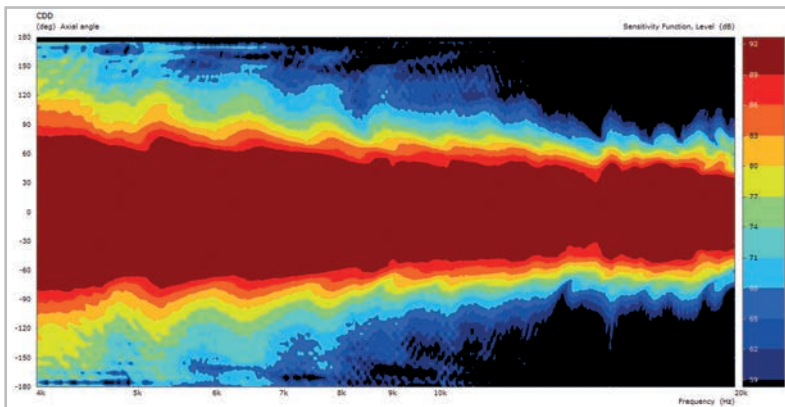

• CDD beamwidth (horizontal)

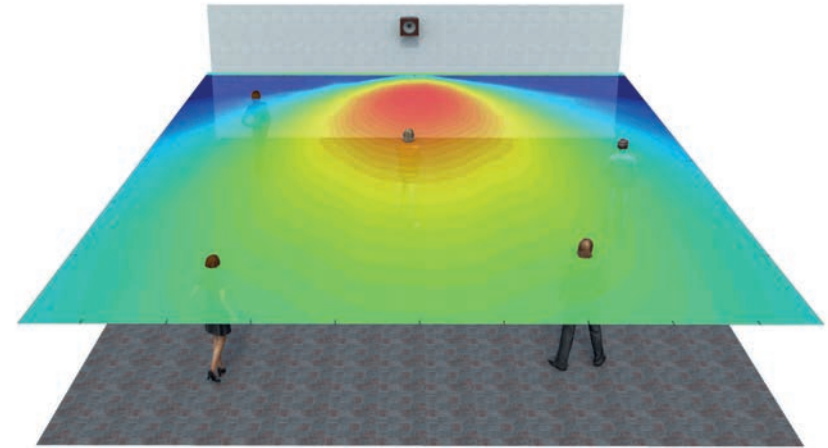

• Conventional $X^\circ \times Y^\circ$ coverage

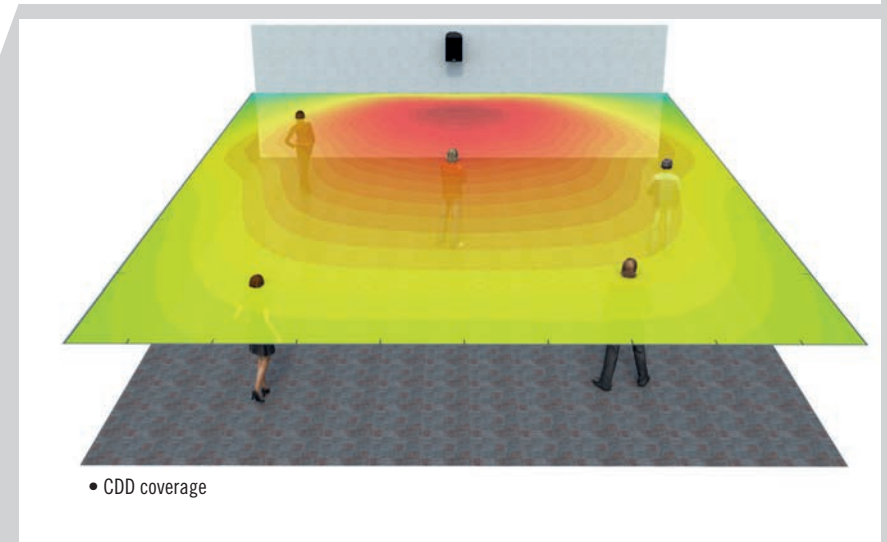

• CDD coverage

achieved very close to the loudspeaker. Walking the room, the consistency in frequency response and SPL — both close to the loudspeaker and further back — is exceptional. The improved coverage close-up also means that CDD-LIVE! speakers can be spaced further apart in some installations, reducing overall speaker count, and similarly a reduction in frontfill/infill speakers in a live sound environment.

ONBOARD AMPLIFICATION, DSP AND DIGITAL NETWORKING

Each CDD-LIVE! system incorporates a powerful electronics module with on-board DSP, Class D amplification and Dante™ digital audio networking — simplifying set-up, enhancing control and eliminating amplifier racks.

Lightweight, switched-mode power supplies auto-range to global mains voltages from 100 to 240V 50/60Hz, while Power Factor Correction smoothes out the mains current draw over the whole of the AC waveform.

DSP functions — including parametric EQ, delay, muting, gain and preset selection — can be controlled over Ethernet from a PC or Windows tablet via intuitive VU-NET™ proprietary software.

For simple set-ups using CDD-LIVE! full-range systems, three ‘plug-and-play’ factory presets for full-range, stage monitor and operation with subs — as well as a user-defined preset — can be selected on the rear panel, instead of using computer control. Four LEDs indicate which preset is selected and can also be switched to operate as a signal level meter. Each subwoofer has presets for operation with either the CDD-LIVE 8, 12 or 15, plus a user-defined preset. Additional presets provide the appropriate settings for the rear-facing subwoofer in a cardioid pair.

An optional rain cowl is available for outdoor use.



THE DANTE ADVANTAGE

Dante is an uncompressed, multi-channel digital media networking technology. It is the preferred audio networking solution of the pro-audio industry owing to its outstanding audio quality and interoperability that is easy to install, easy to set up, versatile, scalable and economic.

Each CDD-LIVE! system is Dante enabled. Delivering significant improvements in Audio over IP technology in terms of speed, high channel count and with near-zero latency, Dante networking opens up tremendous opportunities for digital audio distribution and control — from a front-of-house live music system to a large-scale installation with multiple locations and zones. With audio transmitted digitally over a single CAT5 cable, quality is maintained however long the cable run and integration with other devices in the sound system is straightforward.

Setting up a Dante network is simple — even complex networks can be configured easily and quickly, with all devices discovered and displayed in the Dante Controller software. Once set-up, the computer running Dante Controller can be removed from the network if desired, with system settings stored in the devices themselves and automatically restored when a device is power-cycled.

Switching between XLR analogue inputs to Dante on CDD-LIVE! enclosures is automatic if a digital stream is present, unless the user selects the XLR option in VU-NET.



CDD-LIVE! FULL-RANGE SYSTEMS

Designed for touring and theatre applications, as well as premium fixed installations, CDD-LIVE! full-range systems represent the ultimate in performance and versatility for compact, self-powered professional systems. From the ultra-compact CDD-LIVE 8 to the powerhouse CDD-LIVE 15, CDD-LIVE! full-range systems combine exceptional fidelity with a defined, rectangular dispersion pattern over the audience plane.

CDD-LIVE! is truly versatile. Each multi-angle enclosure can be used in either horizontal or vertical orientation, with rotation of the driver easily accomplished by removing the screw-free, protective grille, while integrated onboard Class D amplification and DSP under proprietary VU-NET software control ensure optimum system performance.



CDD-LIVE 8

The CDD-LIVE 8 is an ultra-compact two-way system featuring an 8" (200mm) LF/1" (25mm) exit HF Coaxial Differential Dispersion driver which can be easily rotated for horizontal or vertical orientation. Its very small size gives no indication of its high output capability. As a stand-alone loudspeaker, it has a multitude of professional applications — from distributed sound reinforcement, HoW and AV events to frontfill/infill and use as a micro stage monitor. Its two-channel onboard Class D amplifier module delivers 1000W LF + 300W HF peak output to the drivers and its sophisticated DSP section performs EQ, crossover and limiter functions as well as driver optimisation.



CDD-LIVE 12

The CDD-LIVE 12 is a high-performance system designed for professional applications that require high output levels from a very compact enclosure. Its high-specification 12" (300mm) LF/1" (25mm) exit HF Coaxial Differential Dispersion driver delivers perfect sound across the audience over medium-throw distances. The LF driver has a 2.5" (65mm) voice coil and efficient motor with an aluminium demodulating ring to minimise distortion, while the HF driver utilises a 1.75" (44mm) polyimide diaphragm and features a low-compression phase plug to reduce non-linearity. The onboard fan-cooled, two-channel Class D amplifier module delivers a total of 2500W peak output to the LF and HF drivers.



CDD-LIVE 15

Ideal for medium-to-large rooms, the CDD-LIVE 15 is a very high-power, self-powered two-way system designed for professional live applications and installations that demand the ultimate in sonic performance from a single enclosure. It combines very high output capability with exceptional fidelity and coverage consistency. Its Coaxial Differential Dispersion driver comprises a powerful 15" (380mm)/3" (75mm) voice coil LF driver and a 1.4" (35mm) exit HF compression driver with a 3" (75mm) pure titanium diaphragm. Its fan-cooled Class D amplifier delivers 2000W LF + 500W HF peak output to the drivers and onboard DSP and Dante networking enhances system performance, flexibility and control.

RECOMMENDED SUBWOOFERS



SXP118

The SXP118 is a compact, high-performance subwoofer that extends the low frequency operating range of a CDD-LIVE full-range system to 40Hz — providing exceptional low frequency impact and increasing headroom. It features a long excursion 18" (460mm)/4" (100 mm) voice coil driver with a water-resistant cone and triple roll surround in a compact reflex enclosure.

The design of the 18" driver maximises output while minimising power compression and distortion, and the four reflex ports have a large frontal area to reduce turbulent air noise at very high levels.

The enclosure is constructed from multi-laminate birch ply, finished with a durable polyurethane coating and equipped with a steel grille, twin grab handles, skids, flying inserts and a threaded pole socket. A twin-fan Class D power module delivers 2000W peak output to the driver, and crossover, EQ, and control functions are provided by the onboard DSP section.



SXP218

The SXP218 achieves the ultimate in subwoofer performance for the most demanding professional applications – delivering very high output levels and superb transient performance with minimal distortion. With an operating range of 35Hz-150Hz ± 3dB, it houses dual 18" long-excursion (460mm)/4" (100mm) voice coil drivers with water-resistant cones and triple roll surrounds.

The enclosure is constructed from multi-laminate birch ply and coated with hardwearing textured paint. Eight reflex ports provide a large frontal area to reduce turbulent air noise, and a perforated steel grille protects the drivers from damage with minimal obstruction of airflow.

The enclosure is equipped with four grab handles, skids and flying inserts. A twin-fan Class D power module delivers 4000W peak output to the drivers, while onboard DSP performs crossover, EQ and control functions.



MULTI-PURPOSE FLEXIBILITY

CDD-LIVE! systems are incredibly flexible and complemented by a comprehensive range of mounting accessories. The CDD-LIVE 8, 12 and 15 can be pole mounted — either directly using their integral pole-mount fittings or with the addition of a universal bracket with a wide range of up and down tilt angles. The up/down tilt angle is easily adjustable and lockable in place. The universal bracket can also be attached to a scaffold clamp for vertical or horizontal suspension from a truss.

Horizontal yokes are available for the CDD-LIVE 12 and 15, while pan and tilt wall brackets for the CDD-LIVE 8 and 12 mount the enclosures as close to the wall as possible. The wall brackets feature a lift-off capability that enables the wall-mounted section to be first-fixed, with the speaker added later.

The CDD-LIVE 8, 12 and 15 are fitted with multiple M8 threaded inserts for eyebolt suspension. The SXP118 and SXP218 are fitted with M10 inserts.

ACCESSORIES

ITEM NUMBER	DESCRIPTION
WB6/8B	CDD-LIVE 8 WALL MOUNT INSTALLATION BRACKET ASSEMBLY
WB10/12B	CDD-LIVE 12 WALL MOUNT INSTALLATION BRACKET ASSEMBLY
CDDCB6/8B	CDD-LIVE 8 CEILING MOUNT (LANDSCAPE) INSTALLATION BRACKET ASSEMBLY
CDDLUB8B	CDD-LIVE 8 UNIVERSAL BRACKET ASSEMBLY
ASF20046	CDD-LIVE 12 UNIVERSAL BRACKET ASSEMBLY
ASF20048	CDD-LIVE 15 UNIVERSAL BRACKET ASSEMBLY
CDDL YA8B	CDD-LIVE 8 YOKE ASSEMBLY
CDDL YA12B	CDD-LIVE 12 YOKE ASSEMBLY
CDDL YA15B	CDD-LIVE 15 YOKE ASSEMBLY
ASF20071	WIND UP POLE FOR CDD-LIVE SERIES
ASF20045	35MM STAND ADAPTOR FOR UNIVERSAL BRACKET
HTKCT05	8MM SHOULDERED EYE BOLT FOR CDD-LIVE 8/12/15
HTKCT6	10MM SHOULDERED EYE BOLT FOR CSX-LIVE 118/218

EASE DATA

To assist system design and speaker placement within a venue, high-resolution GLL files for CDD-LIVE! models are downloadable from the Martin Audio website www.martin-audio.com



• CDD-LIVE 8 Wall Bracket



• CDD-LIVE Yoke



• CDD-LIVE Universal Bracket and Clamp



• CDD-LIVE Universal Bracket and Pole

TECHNICAL SPECIFICATIONS

CDD-LIVE 8

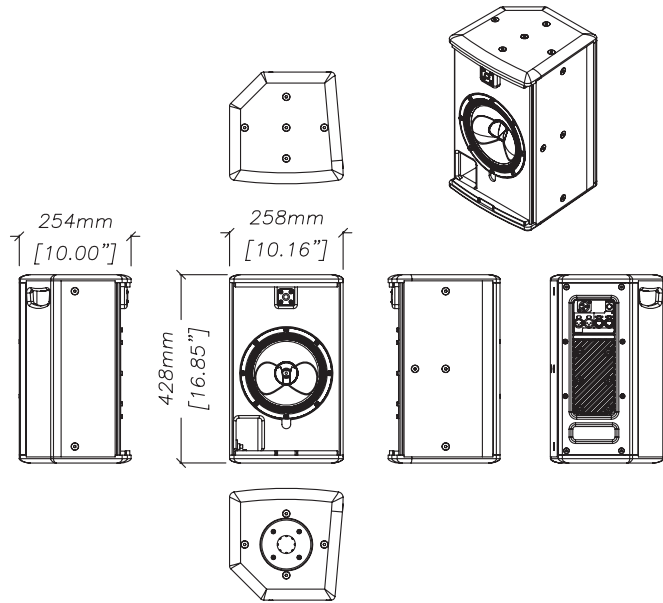

CDD-LIVE 12

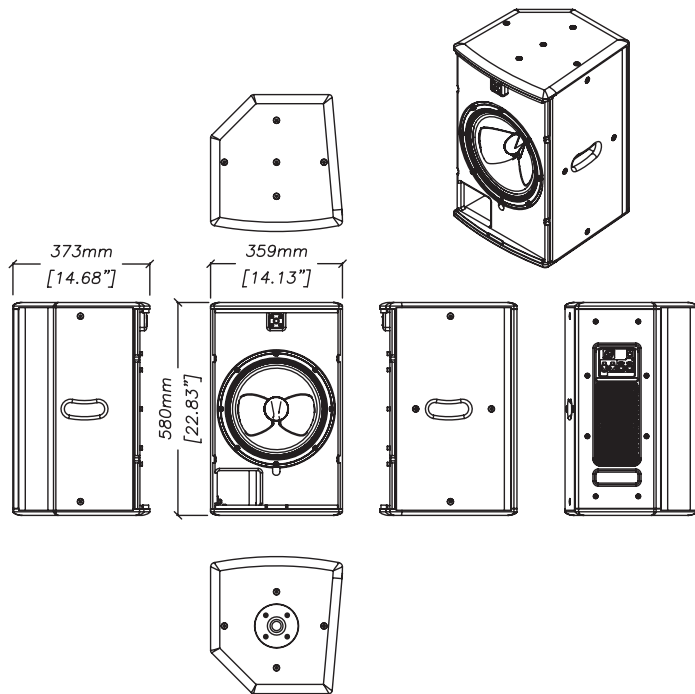

CDD-LIVE 15

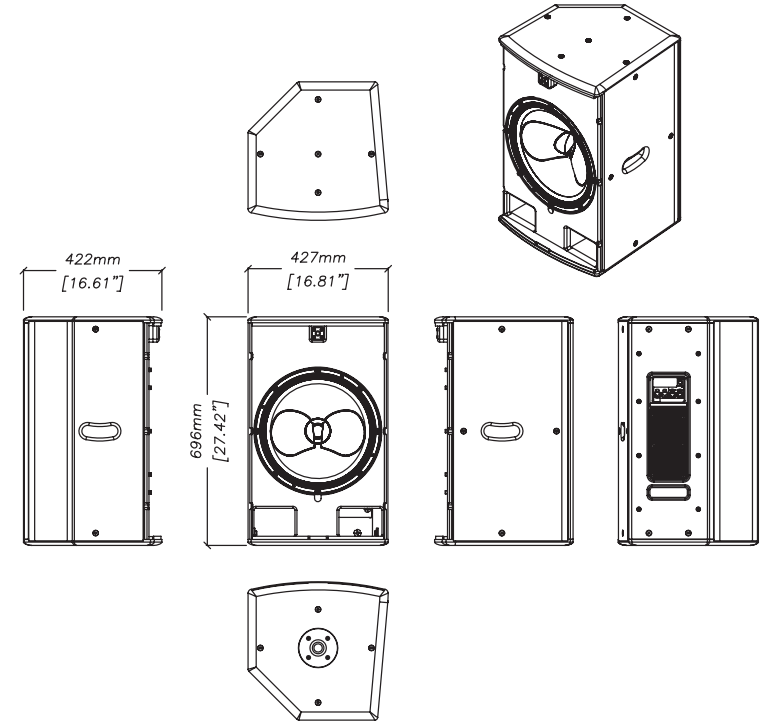

Notes

- (1) Measured on-axis in free space (4 π space) at 2 metres, then referred to 1 metre
- (2) Measured in free space at 1 metre with a tone burst signal
- (3) Measured on-axis on ground plane (2 π space) at 2 metres, then referred to 1 metre
- (4) Measured in half-space at 1 metre with a tone burst signal

CDD-LIVE 8

Acoustics	
TYPE	Ultra-compact, Coaxial Differential Dispersion powered two-way system
FREQUENCY RESPONSE (1)	70Hz – 20kHz \pm 3dB, -10dB @ 50Hz
DRIVER	LF: 8" (200mm)/2" (50mm) voice coil, long excursion, shared ferrite motor system with HF HF: 1" (25mm) exit/1.4" (38mm) voice coil, polyimide dome compression driver
INPUT SENSITIVITY	-13dBu for 100dB SPL
MAXIMUM SPL (2)	117dB continuous / 123dB peak
DISPERSION	110°-80° horizontal, 60° vertical (user-rotatable)
CROSSOVER	2.4kHz Active LR8 Balance presets for pole mount/ pole mount with sub/ stage monitor

Module

Audio input

CONNECTORS	Female XLR input, male XLR link output, Dante Audio Neutrik® Ethercon
ANALOGUE INPUT IMPEDANCE	20 k Ω balanced to ground
MAXIMUM ANALOGUE INPUT LEVEL	24.6 Vpp (+21dBu), over voltage protected

Internal Processing

	Multi-channel DSP, programmable via TCP/IP using VU-Net software
	PEQ/shelving filters
	Up to 48dB/Oct HPF
	Low latency HF FIR filters
	Up to 200ms input delay
	Pre-set selection via rear panel switch

Network

CONNECTORS	2x Neutrik® Ethercon RJ45
PROTOCOL	TCP/IP and UDP/IP

Amplifier Module

TYPE	2 channel switch-mode, class D
PEAK OUTPUT POWER	1300W
CONTINUOUS OUTPUT POWER	650W total
AVERAGE EFFICIENCY	89%
COOLING	External convection cooled, with internal fan
MAXIMUM AMBIENT TEMPERATURE	40°C (104°F) for full output

Power Supply

TYPE	Switch mode, fixed frequency with PFC
AC INPUT OPERATING RANGE	85 – 265V ~ AC, 50 - 60Hz
POWER FACTOR	> 0.98
NOMINAL POWER CONSUMPTION	550W
MAINS CONNECTOR	Neutrik® Powercon True1

Mechanical

ENCLOSURE	Extensively braced multi-laminate plywood.
FINISH	Textured black PU coating.
PROTECTIVE GRILLE	HEX perforated mild steel with protective zinc plating and black powder coat finish. Backed with black grille cloth

FITTINGS

	Top hat for pole mounting
	15 x M8 mounting points
	Single pocket handle
	Optional weather protection cowl

IP RATING

DIMENSIONS	IP24 factory option available (W) 258mm x (H) 428mm x (D) 254mm (W) 10.16in x (H) 16.85in x (D) 10.00in
------------	---

WEIGHT

ACCESSORIES	14kg (30.8lbs) excluding Transit cover Transit Cover Optional wall, yoke and universal brackets
-------------	---

CDD-LIVE 12

Acoustics	
TYPE	Compact, Coaxial Differential Dispersion powered two-way system
FREQUENCY RESPONSE (1)	62Hz – 20kHz \pm 3dB, -10dB @ 50Hz
DRIVER	LF: 12" (300mm)/2.5" (63.5mm) voice coil, long excursion, shared ferrite motor system with HF HF: 1" (25mm) exit/1.7" (44mm) voice coil, polyimide dome compression driver
INPUT SENSITIVITY	-18dBu for 100dB SPL
MAXIMUM SPL (2)	122dB continuous / 128dB peak
DISPERSION	110°-60° horizontal, 60° vertical (user-rotatable)
CROSSOVER	1.8kHz Active LR8 with low latency HF FIR equalisation Balance presets for pole mount/ pole mount with sub/ stage monitor

Module

Audio input

CONNECTORS	Female XLR input, male XLR link output, Dante Audio Neutrik® Ethercon
ANALOGUE INPUT IMPEDANCE	20 k Ω balanced to ground
MAXIMUM ANALOGUE INPUT LEVEL	24.6 Vpp (+21dBu), over voltage protected

Internal Processing

	Multi-channel DSP, programmable via TCP/IP using VU-Net software
	PEQ/shelving filters
	Up to 48dB/Oct HPF
	Low latency HF FIR filters
	Up to 200ms input delay
	Pre-set selection via rear panel switch

Network

CONNECTORS	2x Neutrik® Ethercon
PROTOCOL	TCP/IP and UDP/IP

Amplifier Module

TYPE	2 channel switch-mode, class D, Bridged Tied Load + 1 channel switch-mode, class D
PEAK OUTPUT POWER	2500W
CONTINUOUS OUTPUT POWER	1250W
AVERAGE EFFICIENCY	89%
COOLING	External convection cooled, with internal fan
MAXIMUM AMBIENT TEMPERATURE	40°C (104°F) for full output

Power Supply

TYPE	Switch mode, fixed frequency with PFC
AC INPUT OPERATING RANGE	85 – 265V ~ AC, 50 - 60Hz
POWER FACTOR	> 0.98
NOMINAL POWER CONSUMPTION	550W
MAINS CONNECTOR	Neutrik® Powercon True1

Mechanical

ENCLOSURE	Extensively braced multi-laminate plywood.
FINISH	Textured black PU coating.
PROTECTIVE GRILLE	HEX perforated mild steel with protective zinc plating and black powder coat finish. Backed with black grille cloth

FITTINGS

	Top hat for pole mounting
	15 x M8 mounting points
	Two side pocket handles
	Optional weather protection cowl

IP RATING

DIMENSIONS	IP24 factory option available (W) 359mm x (H) 580mm x (D) 373mm (W) 14.13in x (H) 22.83in x (D) 14.69in
------------	---

WEIGHT

ACCESSORIES	28kg (61.6lbs) excluding Transit cover Transit Cover Optional wall, yoke and universal brackets
-------------	---

CDD-LIVE 15

Acoustics	
TYPE	High-output, Coaxial Differential Dispersion powered two-way system
FREQUENCY RESPONSE (1)	55Hz – 20kHz \pm 3dB, -10dB @ 45Hz
DRIVER	LF: 15" (380mm)/3" (75mm) voice coil, long excursion, shared ferrite motor system with HF HF: 1.4" (36mm) exit/3" (75mm) voice coil, titanium dome compression driver
INPUT SENSITIVITY	-20dBu for 100dB SPL
MAXIMUM SPL (2)	126dB continuous / 132dB peak
DISPERSION	100°-60° horizontal, 60° vertical (user-rotatable)
CROSSOVER	1.7kHz Active LR8 with low latency HF FIR equalisation Balance presets for pole mount/ pole mount with sub/ stage monitor

Module

Audio input

CONNECTORS	Female XLR input, male XLR link output, Dante Audio Neutrik® Ethercon
ANALOGUE INPUT IMPEDANCE	20 k Ω balanced to ground
MAXIMUM ANALOGUE INPUT LEVEL	24.6 Vpp (+21dBu), over voltage protected

Internal Processing

	Multi-channel DSP, programmable via TCP/IP using VU-Net software
	PEQ/shelving filters
	Up to 48dB/Oct HPF
	Low latency HF FIR filters
	Up to 200ms input delay
	Pre-set selection via rear panel switch

Network

CONNECTORS	2x Neutrik® Ethercon
PROTOCOL	TCP/IP and UDP/IP

Amplifier Module

TYPE	2 channel switch-mode, class D, Bridged Tied Load + 1 channel switch-mode, class D
PEAK OUTPUT POWER	2500W
CONTINUOUS OUTPUT POWER	1250W
AVERAGE EFFICIENCY	89%
COOLING	External convection cooled, with internal fan
MAXIMUM AMBIENT TEMPERATURE	40°C (104°F) for full output

Power Supply

TYPE	Switch mode, fixed frequency with PFC
AC INPUT OPERATING RANGE	85 – 265V ~ AC, 50 - 60Hz
POWER FACTOR	> 0.98
NOMINAL POWER CONSUMPTION	550W
MAINS CONNECTOR	Neutrik® Powercon True1

Mechanical

ENCLOSURE	Extensively braced multi-laminate plywood.
FINISH	Textured black PU coating.
PROTECTIVE GRILLE	HEX perforated mild steel with protective zinc plating and black powder coat finish. Backed with black grille cloth.

FITTINGS

	Top hat for pole mounting
	15 x M8 mounting points
	Two side pocket handles
	Optional weather protection cowl

IP RATING

DIMENSIONS	IP24 factory option available (W) 427mm x (H) 696mm x (D) 422mm (W) 16.81in x (H) x 27.42in (D) 16.61in
------------	---

WEIGHT

ACCESSORIES	37kg (81.4lbs) excluding Transit cover Transit Cover Optional yoke and universal brackets
-------------	---

TECHNICAL SPECIFICATIONS

SXP118

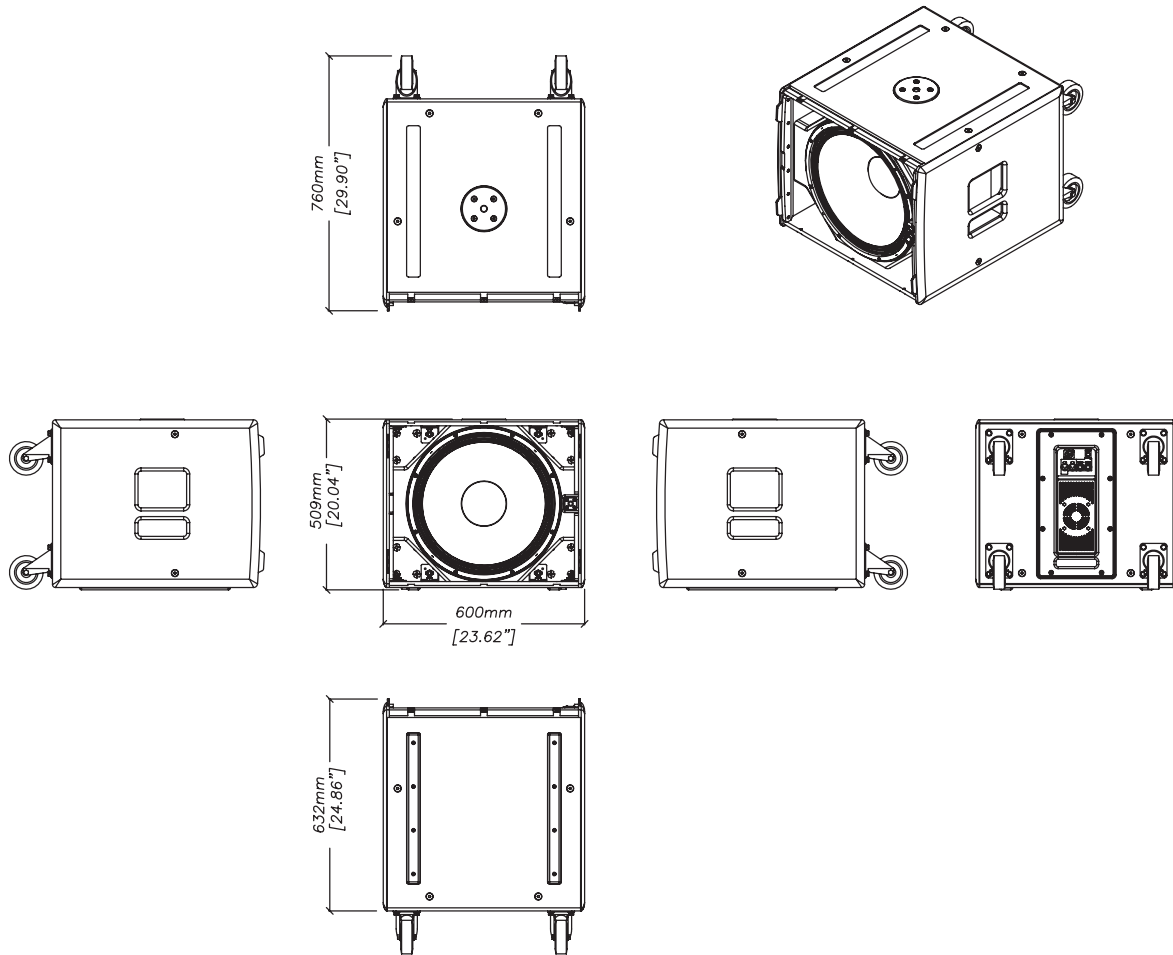

SXP118

Acoustics

TYPE	Compact, direct radiating powered subwoofer
FREQUENCY RESPONSE (3)	47Hz – 150Hz \pm 3dB, -10dB at 41Hz
DRIVER	18" (460mm)/4" (100mm) voice coil, long excursion, ferrite magnet, waterproof cone
INPUT SENSITIVITY	-20dBu for 100dB SPL (CDD12/15 pre-set) -13dBu for 100dB SPL (CDD8 pre-set)
MAXIMUM SPL (4)	132dB continuous / 135dB peak
DISPERSION	Omnidirectional / or Cardioid (paired)
CROSSOVER	Active Presets for CDD Live 8, 12 & 15 mono-pole or cardioid (paired)

Module

Audio input

CONNECTORS	Female XLR input, male XLR link output, Dante Audio Neutrik® Ethercon
ANALOGUE INPUT IMPEDANCE	20 k Ω balanced to ground
MAXIMUM ANALOGUE INPUT LEVEL	24.6 Vpp (+21dBu), over voltage protected

Internal Processing

Multi-channel DSP, programmable via TCP/IP using VU-Net software
PEQ/shelving filters
Up to 48dB/Oct LPF
Up to 200ms input delay
Pre-set selection via rear panel switch

Network

CONNECTORS	2xNeutrik® Ethercon
PROTOCOL	TCP/IP and UDP/IP

Amplifier Module

TYPE	2 channel switch-mode, class D, Bridged Tied
PEAK OUTPUT POWER	2000W
CONTINUOUS OUTPUT POWER	1000W
AVERAGE EFFICIENCY	89%
COOLING	External fan
MAXIMUM AMBIENT TEMPERATURE	40°C (104°F) for full output

Power Supply

TYPE	Switch mode, fixed frequency with PFC
AC INPUT OPERATING RANGE	85 – 265V ~ AC, 50 - 60Hz
POWER FACTOR	> 0.98
NOMINAL POWER CONSUMPTION	550W
MAINS CONNECTOR	Neutrik® Powercon True1

Mechanical

ENCLOSURE	Extensively braced multi-laminate birch plywood
FINISH	Textured black PU coating
PROTECTIVE GRILLE	Black perforated Zintec
FITTINGS	Two skids on base, with mating channels on top Four rear-mounted 100mm (4in) castors M20 top-mounted thread plate for pole mounting 16 x M10 mounting points 2x Bar handles, 1 on each side 4x fittings for optional transit cover

IP RATING	IP24 factory option available
DIMENSIONS	(W) 600mm x (H) 509mm x (D) 632mm (760mm including castors) (W) 23.62in x (H) 20.04in x (D) 24.86in (29.90in including castors)
WEIGHT	46.5kg(103lbs) w/o castors, 50kg (110lbs) with castors
ACCESSORIES	Wheel Kit (Four 100mm (4in) castors), Input Board Cover, Transit Cover

SXP218

Acoustics

TYPE	Dual-driver, direct radiating powered subwoofer
FREQUENCY RESPONSE(3)	35Hz – 150Hz ±3dB, -10dB @ 30Hz
DRIVER	2x 18" (460mm)/4" (100mm) voice coil, long excursion, ferrite magnet, waterproof cone
INPUT SENSITIVITY	-20dBu for 100dB SPL (CDD12/15 pre-set) -13dBu for 100dB SPL (CDD8 pre-set)
MAXIMUM SPL (4)	140dB continuous / 143dB peak
DISPERSION	Omnidirectional / or Cardioid (paired)
CROSSOVER	Active Presets for CDD Live 8, 12 & 15 mono-pole or cardioid (paired)

Module

Audio input

CONNECTORS	Female XLR input, male XLR link output, Dante Audio Neutrik® Ethercon
ANALOGUE INPUT IMPEDANCE	20 kΩ balanced to ground
MAXIMUM ANALOGUE INPUT LEVEL	24.6 Vpp (+21dBu), over voltage protected

Internal Processing

Multi-channel DSP, programmable via TCP/IP using VU-Net software
PEQ/shelving filters
Up to 48dB/Oct LPF
Up to 200mS input delay
Pre-set selection via rear panel switch

Network

CONNECTORS	2xNeutrik® EtherconRJ45
PROTOCOL	TCP/IP and UDP/IP

Amplifier Module

TYPE	Two 2 channel switch-mode, class D, Bridged Tied Load
PEAK OUTPUT POWER	4000W
CONTINUOUS OUTPUT POWER	2000W
AVERAGE EFFICIENCY	89%
COOLING	External fan
MAXIMUM AMBIENT TEMPERATURE	40°C (104°F) for full output

Power Supply

TYPE	Switch mode, fixed frequency with PFC
AC INPUT OPERATING RANGE	85 – 265V ~ AC, 50 - 60Hz
POWER FACTOR	> 0.98
NOMINAL POWER CONSUMPTION	550W
MAINS CONNECTOR	Neutrik® Powercon True1

Mechanical

ENCLOSURE	Extensively braced multi-laminate birch plywood
FINISH	Textured black PU coating
PROTECTIVE GRILLE	Black perforated Zintec
FITTINGS	Two skids on base, with mating channels on top Four rear-mounted 100mm (4in) castors 24 x M10 mounting points 4x Bar handles, 2 on each side 4x fittings for optional transit cover
IP RATING	IP24 factory option available
DIMENSIONS	(W) 1085mm x (H) 537mm x (D) 792mm (920mm including castors) (W) 42.72in x (H) 21.13in x (D) 31.20in (36.20in including castors)
WEIGHT	101.5kg (224lbs) w/o castors 105kg (231lbs) with castors
ACCESSORIES	Wheel Kit (Four 100mm (4in) castors), Input Board Cover, Transit Cover

SXP218

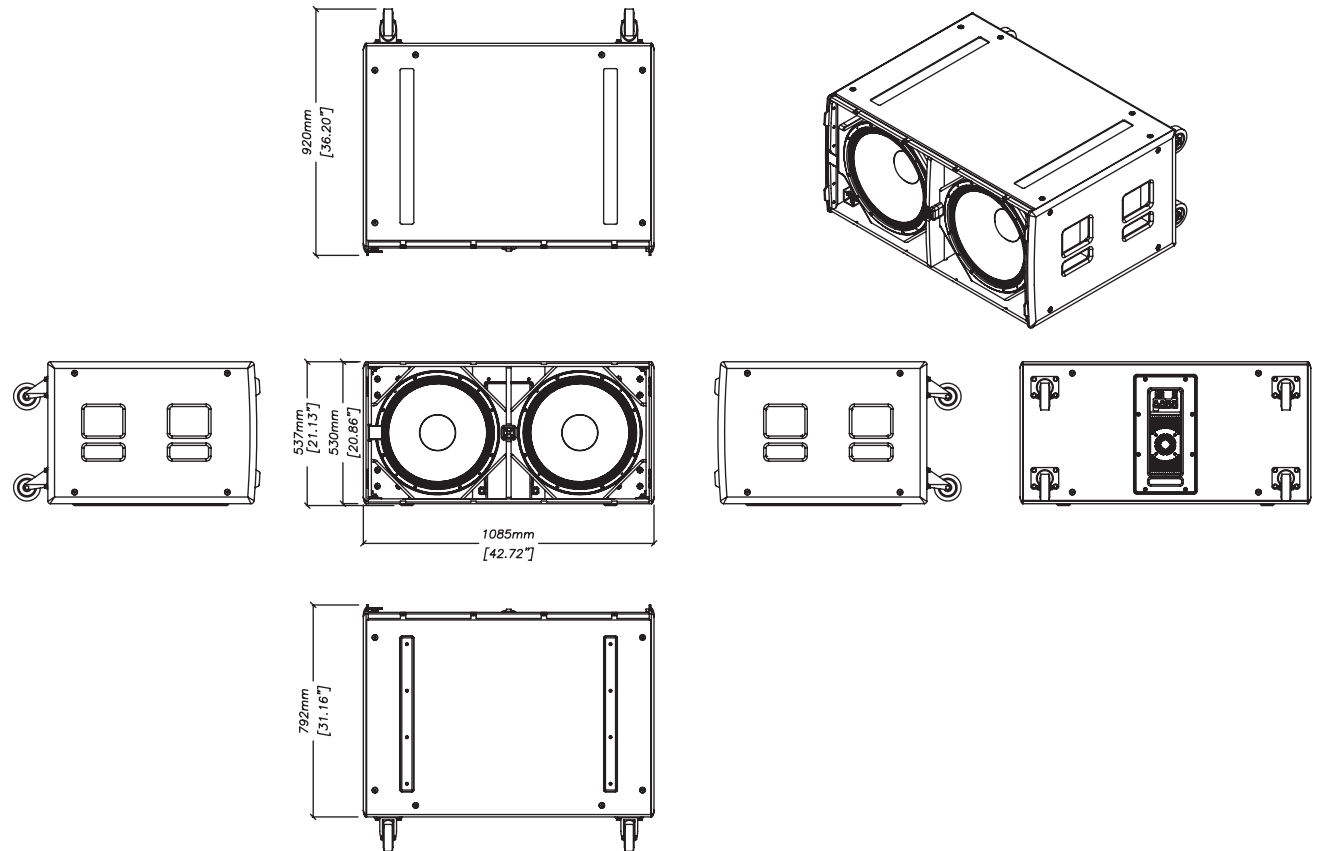

Notes

- (1) Measured on-axis in free space (4 π space) at 2 metres, then referred to 1 metre
- (2) Measured in free space at 1 metre with a tone burst signal
- (3) Measured on-axis on ground plane (2 π space) at 2 metres, then referred to 1 metre
- (4) Measured in half-space at 1 metre with a tone burst signal



THE SOUND OF THINGS TO COME

Martin Audio Limited

Century Point

Halifax Road

Cressex Business Park

High Wycombe

Buckinghamshire

HP12 3SL

England

FOR SALES ENQUIRIES:

UK

Telephone: +44 (0)1494 535312

E-mail: info@martin-audio.com

NORTH AMERICA

Telephone: 519 747 5853

E-mail: infona@martin-audio.com

All information is Copyright © 2018 Martin Audio Ltd. Dante™ is a trademark of Audinate Pty Ltd.

Martin Audio, the Martin Audio logo and Hybrid are registered trademarks of Martin Audio Ltd. in the United Kingdom, United States and other countries; all other Martin Audio trademarks are the property of Martin Audio Ltd.

www.martin-audio.com

Unite Your Audience

The Martin Audio Experience

Version 3.0