

# **SEVEN BATTEN 42™**

user manual

**©2018 ELATION PROFESSIONAL** all rights reserved. Information, specifications, diagrams, images, and instructions herein are subject to change without notice. ELATION PROFESSIONAL logo and identifying product names and numbers herein are trademarks of ELATION PROFESSIONAL. Copyright protection claimed includes all forms and matters of copyrightable materials and information now allowed by statutory or judicial law or hereinafter granted. Product names used in this document may be trademarks or registered trademarks of their respective companies and are hereby acknowledged. All non-ELATION brands and product names are trademarks or registered trademarks of their respective companies.

**ELATION PROFESSIONAL** and all affiliated companies hereby disclaim any and all liabilities for property, equipment, building, and electrical damages, injuries to any persons, and direct or indirect economic loss associated with the use or reliance of any information contained within this document, and/or as a result of the improper, unsafe, insufficient and negligent assembly, installation, rigging, and operation of this product.

**Elation Professional USA** | 6122 S. Eastern Ave. | Los Angeles, CA. 90040

323-582-3322 | Fax 323-832-9142 | [www.elationlighting.com](http://www.elationlighting.com) | [info@elationlighting.com](mailto:info@elationlighting.com)

**Elation Professional B.V.** | Junostraat 2 | 6468 EW Kerkrade, The Netherlands

+31 45 546 85 66 | Fax +31 45 546 85 96 | [www.elationlighting.eu](http://www.elationlighting.eu) | [info@elationlighting.eu](mailto:info@elationlighting.eu)

**Elation Professional Mexico** | AV Santa Ana 30 | Parque Industrial Lerma, Lerma, Mexico 52000

+52 (728) 282-7070

**DOCUMENT VERSION**

**Due to additional product features and/or enhancements, an updated version of this document may be available online.**

**Please check [www.elationlighting.com](http://www.elationlighting.com) for the latest revision/update of this manual, before beginning installation and/or programming.**

<b>Date</b>	<b>Document Version</b>	<b>Software Version ≥</b>	<b>DMX Channel Modes</b>	<b>Notes</b>
08/23/18	1	2.02	10	Initial release.
01/22/19	1.2	N/C	NO CHANGE	Updated dimensions.

# CONTENTS

General Information	4
Limited Warranty (USA Only)	5
Safety Guidelines	6
Maintenance Guidelines	8
Fixture Overview	9
Installation Guidelines	10
System Menu	13
DMX Channel Functions and Values	17
Specifications	24
Optional Accessories	27

# GENERAL INFORMATION

## INTRODUCTION

Please read and understand the instructions in this manual carefully and thoroughly before attempting to operate this fixture. These instructions contain important safety and use information.

## UNPACKING

Every fixture has been thoroughly tested and has been shipped in perfect operating condition. Carefully check the shipping carton for damage that may have occurred during shipping. If the carton is damaged, carefully inspect the fixture for damage, and be sure all accessories necessary to install and operate the fixture have arrived intact. In the event damage has been found or parts are missing, please contact our customer support team for further instructions. Please do not return this fixture to your dealer without first contacting customer support. Please do not discard the shipping carton in the trash. Please recycle whenever possible.

## BOX CONTENTS

Power Cable  
Safety Cable

## CUSTOMER SUPPORT

Contact ELATION Service for any product related service and support needs. Also visit [forums.elationlighting.com](https://forums.elationlighting.com) with questions, comments or suggestions.

**ELATION SERVICE USA - Monday - Friday 8:00am to 4:30pm PST**  
323-582-3322 | Fax 323-832-9142 | [support@elationlighting.com](mailto:support@elationlighting.com)

**ELATION SERVICE EUROPE - Monday - Friday 08:30 to 17:00 CET**  
+31 45 546 85 63 | Fax +31 45 546 85 96 | [support@elationlighting.eu](mailto:support@elationlighting.eu)

**REPLACEMENT PARTS** please visit [parts.elationlighting.com](https://parts.elationlighting.com)



## **I M P O R T A N T   N O T I C E !**

**THERE ARE NO USER SERVICEABLE PARTS INSIDE THIS UNIT.  
DO NOT ATTEMPT ANY REPAIRS YOURSELF; DOING SO WILL VOID YOUR  
MANUFACTURES WARRANTY. DAMAGES RESULTING FROM MODIFICATIONS TO  
THIS FIXTURE AND/OR THE DISREGARD OF SAFETY INSTRUCTIONS AND  
GUIDELINES IN THIS MANUAL VOID THE MANUFACTURES WARRANTY AND ARE  
NOT SUBJECT TO ANY WARRANTY CLAIMS AND/OR REPAIRS.**

## **LIMITED WARRANTY (USA ONLY)**

A. Elation Professional hereby warrants, to the original purchaser, Elation Professional products to be free of manufacturing defects in material and workmanship for a period of two years (730 days), and Elation Professional product rechargeable batteries to be free of manufacturing defects in material and workmanship for a period of six months (180 days), from the original date of purchase. This warranty excludes discharge lamps and all product accessories. This warranty shall be valid only if the product is purchased within the United States of America, including possessions and territories. It is the owner's responsibility to establish the date and place of purchase by acceptable evidence, at the time service is sought. B. For warranty service, send the product only to the Elation Professional factory. All shipping charges must be pre-paid. If the requested repairs or service (including parts replacement) are within the terms of this warranty, Elation Professional will pay return shipping charges only to a designated point within the United States. If any product is sent, it must be shipped in its original package and packaging material. No accessories should be shipped with the product. If any accessories are shipped with the product, Elation Professional shall have no liability what so ever for loss and/or or damage to any such accessories, nor for the safe return thereof. C. This warranty is void if the product serial number and/or labels are altered or removed; if the product is modified in any manner which Elation Professional concludes, after inspection, affects the reliability of the product; if the product has been repaired or serviced by anyone other than the Elation Professional factory unless prior written authorization was issued to purchaser by Elation Professional; if the product is damaged because not properly maintained as set forth in the product instructions, guidelines and/or user manual. D. This is not a service contract, and this warranty does not include any maintenance, cleaning or periodic check-up. During the periods as specified above, Elation Professional will replace defective parts at its expense, and will absorb all expenses for warranty service and repair labor by reason of defects in material or workmanship. The sole responsibility of Elation Professional under this warranty shall be limited to the repair of the product, or replacement thereof, including parts, at the sole discretion of Elation Professional. All products covered by this warranty were manufactured after January 1, 1990, and bare identifying marks to that effect. E. Elation Professional reserves the right to make changes in design and/or performance improvements upon its products without any obligation to include these changes in any products theretofore manufactured. F. No warranty, whether expressed or implied, is given or made with respect to any accessory supplied with the products described above. Except to the extent prohibited by applicable law, all implied warranties made by Elation Professional in connection with this product, including warranties of merchantability or fitness, are limited in duration to the warranty periods set forth above. And no warranties, whether expressed or implied, including warranties of merchantability or fitness, shall apply to this product after said periods have expired. The consumer's and/or dealer's sole remedy shall be such repair or replacement as is expressly provided above; and under no circumstances shall Elation Professional be liable for any loss and/or damage, direct and/or consequential, arising out of the use of, and/or the inability to use, this product. G. This warranty is the only written warranty applicable to Elation Professional products and supersedes all prior warranties and written descriptions of warranty terms and conditions heretofore published.

### **WARRANTY RETURNS**

All returned service items whether under warranty or not, must be freight pre-paid and accompany a return authorization (R.A.) number. The R.A. number must be clearly written on the outside of the return package. A brief description of the problem as well as the R.A. number must also be written down on a piece of paper and included in the shipping container. If the unit is under warranty, you must provide a copy of your proof of purchase invoice. Items returned without a R.A. number clearly marked on the outside of the package will be refused and returned at customer's expense. You may obtain a R.A. number by contacting customer support. **ONLY** Use the original packaging and materials to transport the fixture in for service.

# SAFETY GUIDELINES

This fixture is a sophisticated piece of electronic equipment. To guarantee a smooth operation, it is important to follow all instructions and guidelines in this manual. Elation Professional is not responsible for injury and/or damages resulting from the misuse of this fixture due to the disregard of the information printed in this manual. Only qualified and/or certified personnel should perform installation of this fixture and only the original rigging parts (omega brackets) included with this fixture should be used for installation. Any modifications to the fixture and/or the included mounting hardware will void the original manufactures warranty and increase the risk of damage and/or personal injury.



**PROTECTION CLASS 1 - FIXTURE MUST BE PROPERLY GROUNDED**



**THERE ARE NO USER SERVICEABLE PARTS INSIDE THIS UNIT.  
DO NOT ATTEMPT ANY REPAIRS YOURSELF; DOING SO WILL VOID YOUR MANUFACTURES WARRANTY. DAMAGES RESULTING FROM MODIFICATIONS TO THIS FIXTURE AND/OR THE DISREGARD OF SAFETY INSTRUCTIONS AND GUIDELINES IN THIS MANUAL VOID THE MANUFACTURES WARRANTY AND ARE NOT SUBJECT TO ANY WARRANTY CLAIMS AND/OR REPAIRS.**



**DO NOT PLUG FIXTURE INTO A DIMMER PACK!  
NEVER OPEN THIS FIXTURE WHILE IN USE!  
UNPLUG POWER BEFORE SERVICING FIXTURE!  
NEVER TOUCH FIXTURE DURING OPERATION, AS IT MAY BE HOT!  
KEEP FLAMMABLE MATERIALS AWAY FROM FIXTURE!**



**NEVER LOOK DIRECTLY INTO THE LIGHT SOURCE!  
RETINA INJURY RISK - MAY INDUCE BLINDNESS!  
SENSITIVE PERSONS MAY SUFFER AN EPILEPTIC SHOCK!**



**INDOOR / DRY LOCATIONS USE ONLY!  
DO NOT EXPOSE FIXTURE TO RAIN AND MOISTURE!**

# SAFETY GUIDELINES

## **CAUTION**

### **HIGH INTENSITY ULTRAVIOLET LIGHT**

AVOID DIRECT EYE & SKIN EXPOSURE.  
WEAR PROPER EYE & SKIN PROTECTION.  
SEE MANUAL FOR SAFETY INSTRUCTIONS.



**RISK GROUP 3 - RISK OF EXPOSURE TO ULTRAVIOLET UV RADIATION! FIXTURE EMITS HIGH INTENSITY WAVELENGTH OF ULTRAVIOLET UV LIGHT FROM THE UV LED. WEAR PROPER EYE AND SKIN PROTECTION. AVOID PROLONGED PERIODS OF EXPOSURE TO UV LED. AVOID WEARING WHITE COLOR CLOTHING AND/OR USING UV PAINTS ON SKIN. AVOID DIRECT EYE AND/OR SKIN EXPOSURE AT DISTANCES LESS THAN 11 feet (3.3m). DO NOT OPERATE FIXTURE WITH DAMAGED/MISSING EXTERNAL COVERS. DO NOT LOOK DIRECTLY INTO THE UV LIGHT AND/OR VIEW UV LIGHT DIRECTLY WITH OPTICAL INSTRUMENTS THAT MAY CONCENTRATE THE LIGHT/RADIATION OUTPUT. INDIVIDUALS SUFFERING FROM A RANGE OF EYE CONDITIONS, SUNLIGHT EXPOSURE DIS-ORDERS, OR INDIVIDUALS USING PHOTSENSITIVE MEDICATION, MAY RECEIVE DISCOMFORT IF EXPOSED TO THE ULTRAVIOLET UV LIGHT EMITTED FROM THE UV LED.**

**DO NOT TOUCH** the fixture housing during operation. Turn OFF the power and allow approximately 15 minutes for the fixture to cool down before serving.

**DO NOT** shake fixture, avoid brute force when installing and/or operating fixture.

**DO NOT** operate fixture if the power cord is frayed, crimped, damaged and/or if any of the power cord connectors are damaged and do not insert into the fixture securely with ease. **NEVER** force a power cord connector into the fixture. If the power cord or any of its connectors are damaged, replace it immediately with a new one of similar power rating.

**DO NOT** block any air ventilation slots.

All fan and air inlets must remain clean and never blocked.

Allow approx. 6" (15cm) between fixture and other devices or a wall for proper cooling.

When installing fixture in a suspended environment, always use mounting hardware that is no less than M10 x 25 mm, and always install fixture with an appropriately rated safety cable.

Always disconnect fixture from main power source before performing any type of service and/or cleaning procedure. Only handle the power cord by the plug end, never pull out the plug by tugging the wire portion of the cord.

During the initial operation of this fixture, a light smoke or smell may emit from the interior of the fixture. This is a normal process and is caused by excess paint in the interior of the casing burning off from the heat associated with the lamp and will decrease gradually over time.

Consistent operational breaks will ensure fixture will function properly for many years.

# MAINTENANCE GUIDELINES



**DISCONNECT POWER BEFORE PERFORMING ANY MAINTENANCE!**

## CLEANING

Frequent cleaning is recommended to insure proper function, optimized light output, and an extended life. The frequency of cleaning depends on the environment in which the fixture operates: damp, smoky or particularly dirty environments can cause greater accumulation of dirt on the fixture's optics. Clean the external lens surface at least every 20 days with a soft cloth to avoid dirt/debris accumulation.

**NEVER** use alcohol, solvents, or ammonia-based cleaners.

## MAINTENANCE

Regular inspections are recommended to insure proper function and extended life.

There are no user serviceable parts inside this fixture, please refer all other service issues to an authorized Elation service technician. Should you need any spare parts, please order genuine parts from your local Elation dealer.

Please refer to the following points during routine inspections:

A detailed review by an approved electrical engineer every three months, to make sure the circuit contacts are in good condition and prevent overheating.

Be sure all screws and fasteners are securely tightened at all times. Loose screws may fall out during normal operation resulting in damage or injury as larger parts could fall.

Check for any deformations on the housing, color lenses, rigging hardware and rigging points (ceiling, suspension, trussing). Deformations in the housing could allow for dust to enter into the fixture. Damaged rigging points or unsecured rigging could cause the fixture to fall and seriously injure a person(s).

Electric power supply cables must not show any damage, material fatigue or sediments.

**NEVER** remove the ground prong from the power cable.



# FIXTURE OVERVIEW

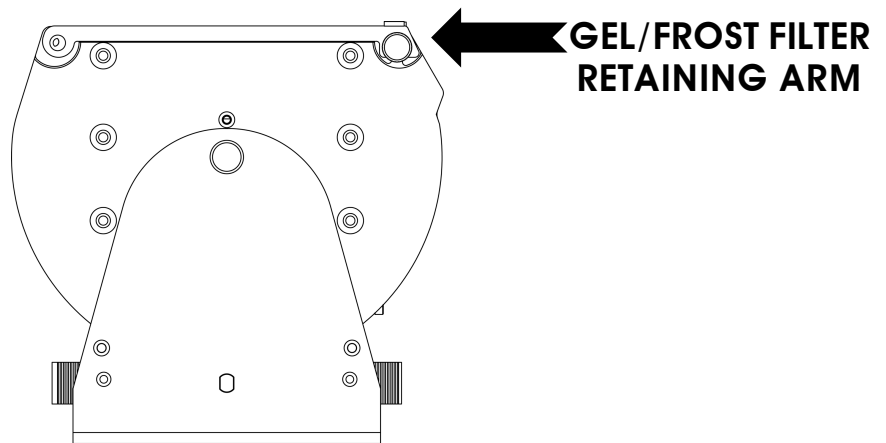
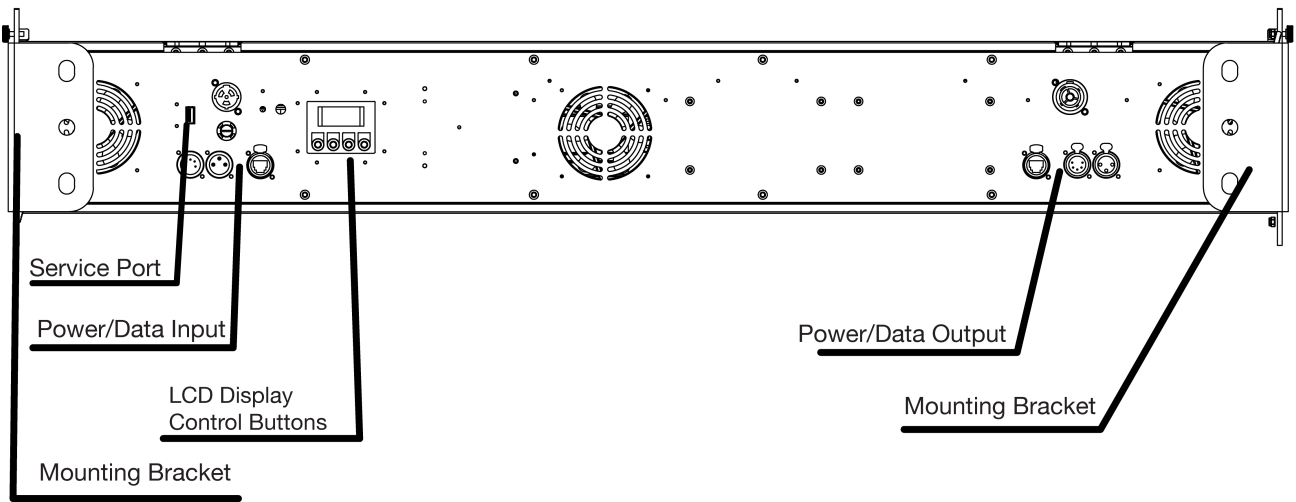
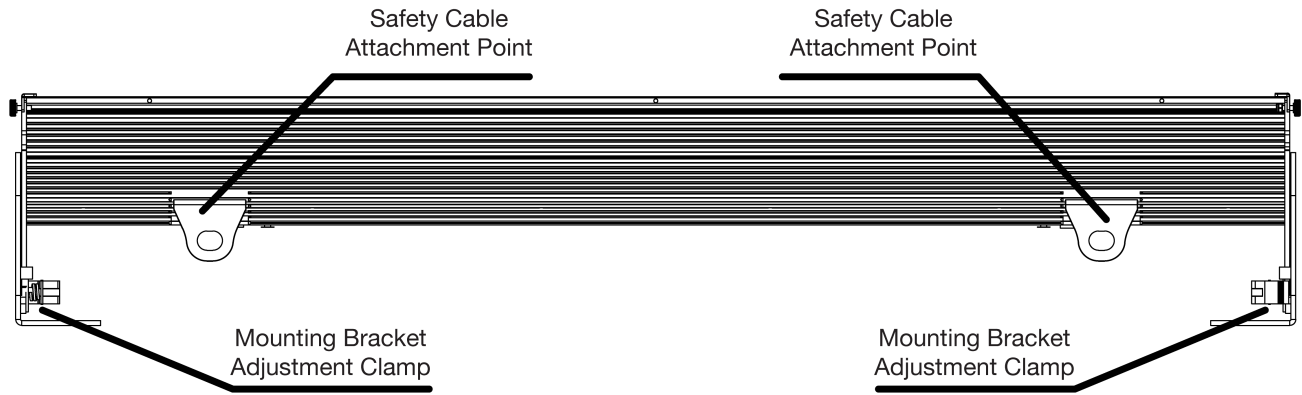

# INSTALLATION GUIDELINES



## **FLAMMABLE MATERIAL WARNING**

Keep fixture minimum 5.0 feet (1.5m) away from flammable materials and/or pyrotechnics.



## **ELECTRICAL CONNECTIONS**

A qualified electrician should be used for all electrical connections and/or installations.



**USE CAUTION WHEN POWER LINKING OTHER MODEL FIXTURES AS THE POWER CONSUMPTION OF OTHER MODEL FIXTURES MAY EXCEED THE MAX POWER OUTPUT ON THIS FIXTURE. CHECK SILK SCREEN FOR AMX AMPS.**



**DO NOT INSTALL THE FIXTURE IF YOU ARE NOT QUALIFIED TO DO SO!**

Fixture **MUST** be installed following all local, national, and country commercial electrical and construction codes and regulations.

Before rigging/mounting a single fixture or multiple fixtures to any metal truss/structure or placing the fixture(s) on any surface, a professional equipment installer **MUST** be consulted to determine if the metal truss/structure or surface is properly certified to safely hold the combined weight of the fixture(s), clamps, cables, and accessories.

Fixture ambient operating temperature range is **14° to 113°F. (-10° to 45°C)**  
Do not use the fixture under or above this temperature.

Fixture(s) should be installed in areas outside walking paths, seating areas, or away from areas where unauthorized personnel might reach the fixture by hand.

**NEVER** stand directly below the fixture(s) when rigging, removing or servicing.  
Overhead fixture installation must always be secured with a secondary safety attachment, such as an appropriately rated safety cable.

Allow approximately 15 minutes for the fixture to cool down before serving.

# INSTALLATION GUIDELINES

## CLAMP MOUNTING

The fixture includes adjustable mounting brackets on both ends, which include 3-position holes for versatile fixture positioning. When mounting this fixture to truss or a metal structure, be sure to secure an appropriately rated clamp (not included) to both brackets using M10 screws. Depending on the rigging position of the fixture, it may be best to use more than one clamp attached to the mounting brackets and more than one safety cable.



**MAKE SURE TO TIGHTEN BOTH MOUNTING BRACKET ADJUSTMENT CLAMPS BEFORE INSTALLING FIXTURE TO TRUSS OR A METAL STRUCTURE.**

## SAFETY CABLE

The fixture includes 2 integrated safety cable rigging points. (see image below)



**ALWAYS ATTACH A SAFETY CABLE WHENEVER INSTALLING THIS FIXTURE IN A SUSPENDED ENVIRONMENT TO ENSURE THE FIXTURE WILL NOT DROP IF THE CLAMP FAILS.**

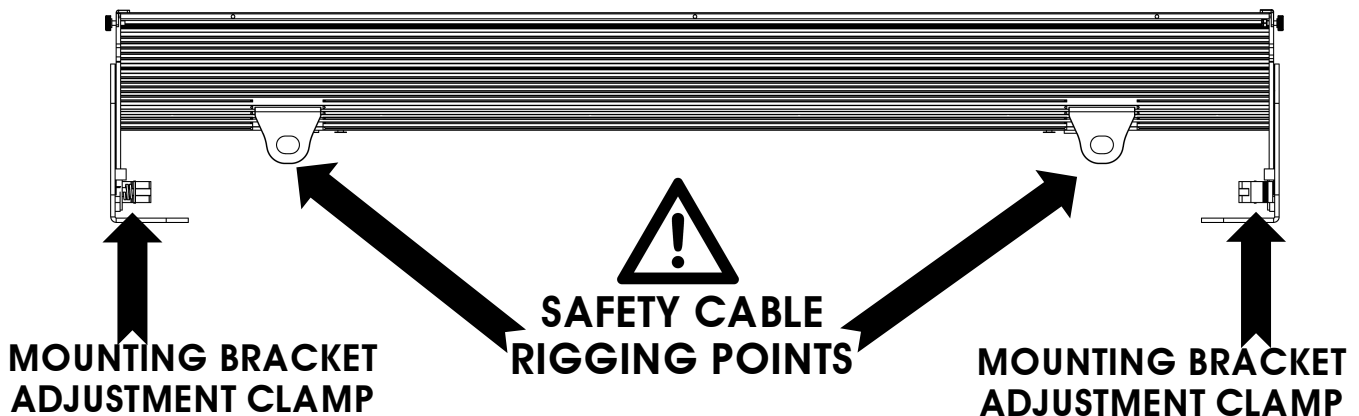

## OVERHEAD RIGGING

Overhead rigging requires extensive experience, including amongst others calculating working load limits, installation material being used, and periodic safety inspection of all installation material and the fixture. If you lack these qualifications, do not attempt the installation yourself. Improper installation can result in bodily injury and property damage.

## POWER LINKING



**USE CAUTION WHEN POWER LINKING OTHER MODEL FIXTURES AS THE POWER CONSUMPTION OF OTHER MODEL FIXTURES MAY EXCEED THE MAX POWER OUTPUT ON THIS FIXTURE. CHECK SILK SCREEN FOR AMX AMPS.**

# INSTALLATION GUIDELINES

## KLING-NET / ART-NET CONNECTION

When connecting fixture to a network switch to control multiple devices, a **Gigabit Ethernet Switch** that supports **IGMP (Internet Group Management Protocol)** is required. Using a **Gigabit Ethernet Switch** that does not support **IGMP** can cause erratic behavior of all connected devices to the switch. Click link below for more information about IGMP. [https://en.wikipedia.org/wiki/Internet\\_Group\\_Management\\_Protocol](https://en.wikipedia.org/wiki/Internet_Group_Management_Protocol)

## GEL / FROST FILTER INSTALLATION

A thin precut Gel / Frost Filter (not included) can be added to alter the light output.

1. Turn thumbscrew counter-clockwise.
2. Lift retaining arm up.
3. Insert Gel/Frost Filter by sliding into groove slots on top of LED array lens.
4. Lower retaining arm into place and turn thumbscrew clockwise to secure.

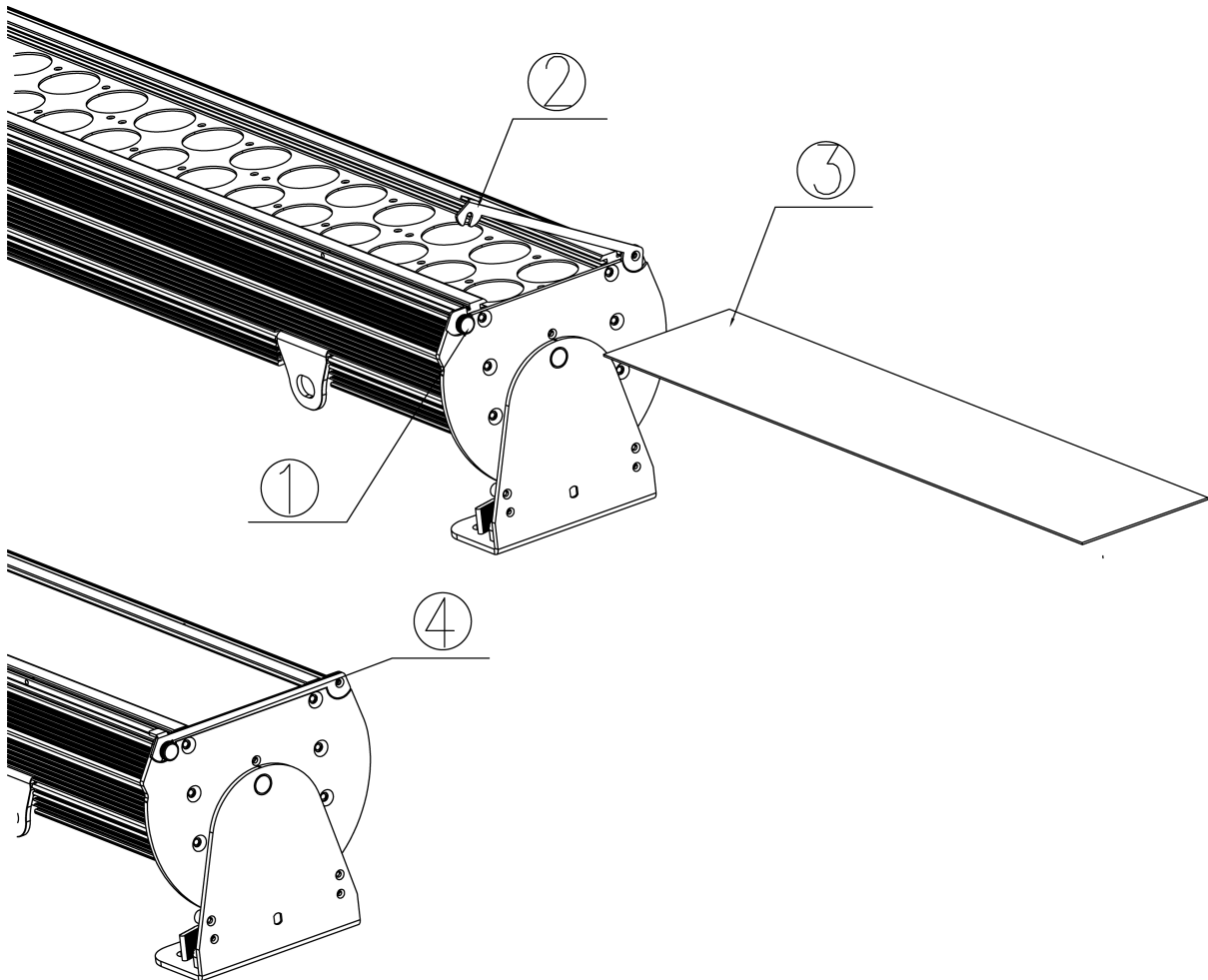

# SYSTEM MENU

The fixture includes an easy to navigate system menu where fixture settings can be adjusted via the LCD control panel located on the back of the fixture. (see image below) During normal operation, pressing the **MODE** button once will access the main menu. Navigate through the various sub-menus by pressing the **UP** and **DOWN** buttons, press the **ENTER** button to select a specific sub-menu, press the **UP** and **DOWN** buttons to adjust the selected sub-menu settings, and press the **ENTER** button again to confirm the sub-menu setting selection. Exit the main system menu at any time without making any adjustments by pressing the **MODE** button.

To access the system menu press and hold the **MODE** button for 3 seconds. The LCD Menu Control Display will shut **OFF** automatically about 1 minute from the last button press.

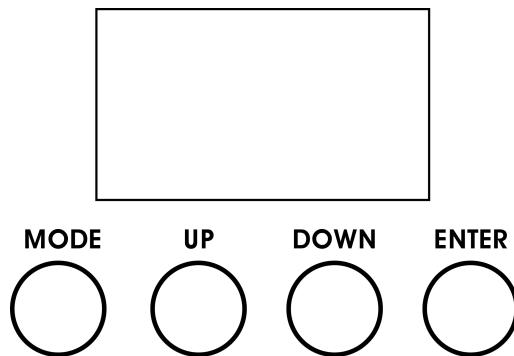

## LCD CONTROL PANEL LOCKOUT

When **Display** sub menu is set to **ON**, the LCD display backlight will turn OFF after 30 seconds and the Control Panel buttons will lock, and the display will show **Locked**. Press and hold the **MODE** button for 5 seconds to unlock.

When **Display sub** menu is set to **ON1**, the LCD display backlight will turn OFF after 30 seconds and the Control Panel will lock, and the display will show **LOCKED\*\*\*\*\***.

To unlock follow these steps:

1. When locked, the display will show: **LOCKED\*\*\*\*\***
2. Press **UP**, then the display will change to: **LOCKED\*\*\*\*** (one \* disappears)
3. Press **DOWN**, then the display will change to: **LOCKED\*\*\*** (two \* disappear)
4. Press **UP**, then the display will change to: **LOCKED\*\*** (three \* disappear)
5. Press **DOWN**, then the display will change to: **LOCKED\*** (4 \* disappear)
6. Press **ENTER**, then the display will change to **LOCKED** and then become unlocked.

## SYSTEM MENU

Supports Software Versions: ≥ 2.02

Features are subject to change without any prior written notice.

MENU	SUB MENU	OPTIONS / VALUES (Default Settings in BOLD)		DESCRIPTION	
Address	Set ADDR	<b>001</b> ~ xxx		DMX Address Setting	
Mode		RGB 3CH, RGBSeven 3CH, 8bit 7CH, 16bit 14CH, <b>Master 15CH</b> , Cells 42CH, MastCell 50CH, HSI 4CH, HSI Mast 10CH, HIS Cell 26CH		DMX Channel / User Mode	
Function	No DMX	<b>Hold</b> / Black / Program		Function If NO DMX Detected	
	LCD.Set	Display	<b>On</b> / Off		LCD Backlight Shut Off Time
		Key Lock	<b>On</b> / On1 / Off		LCD Buttons Key Lock (see page 13 for details)
		Flash	<b>On</b> / Off		Display flashes when NO DMX
		Inverse	On / <b>Off</b>		Flips LCD Display 180 Degrees
	Temp. C/F	<b>F</b> / C		Temperature Switch Between F° / C°	
	DimCurve	<b>Standard</b> , Stage, TV, Architec, Theatre, Stage2		Set Dimmer Curve Mode	
	Disp.Set	ADDR, Disp.CH		Select Default Display	
	Fan	<b>Auto</b> , High, Low		Set Fans Speed	
	Cell Orde	<b>Standard</b> , Flip		Set Pixel Flip Mode (See page 16 for details)	
	Gamma	<b>2.0</b> , 2.2, 2.4, 2.8		Set Gamma Brightness	
	Frequen	<b>900Hz</b> , 1000Hz, 1100Hz, 1200Hz, 1300Hz, 1400Hz, 1500Hz, 2500Hz, 4000Hz, 5000Hz, 10Hz, 15Hz, 20Hz, 25Hz		Set LED Refresh Frequency	
	Network	Universe	<b>001</b> -256		Enter Fixture Universe
		IP	XXX.XXX.XXX.XXX		Enter Fixture IP Address
		Subnet	XXX.XXX.XXX.XXX		Enter Fixture Subnet Mask
		Protocol	<b>Artnet</b> / Klingnet		Select Network Protocol
	Net	<b>On</b> / Off		Enable Network Protocol Auto-Detection	
USB	On / <b>Off</b>		Enable Service Port for Software Updates		
Defaults	Reset? / <b>Cancel</b>		Restore Factory Settings		
Program	Speed	<b>1</b> -99		Set Program Speed from Slow (1) to Fast (99)	
	Color	STATIC	Strobe 000- <b>255</b> R, G, B, RG, GB, RB, RGB, BLACK		Select Static Color and Shutter/Strobe Value
		CHANG15	Strobe 000- <b>255</b>		Select 15 Color Program + Shutter/Strobe Value
		CHANG30	Strobe 000- <b>255</b>		Select 30 Color Program + Shutter/Strobe Value
		FADE	Strobe 000- <b>255</b>		Select Fade Color Program + Shutter/Strobe Value
	Macros	<b>0</b> -63		Select Color Macro	
Slave	<b>OFF</b> , SLAVE		Enable Slave Mode		
Info	TimeInfo	Current	XXXX (Hours)		Fixture Run Time from Power ON
		Total	XXXX (Hours)		Fixture Total Run Time
		Last	XXXX (Hours)		Fixture Last Run Time
		PassWord	PIN= <b>050</b>		Enter PIN to Access Clear Last. Menu
		Clear	<b>Off</b> / On		Clear Fixture Last Run Time
	TempInfo	XXX <b>F°</b> / C°		Temperature in Fixture Head	
	Err.Info	Error Record 1 ~ Error Record 10		Display 10 Recent Error Messages	
	Modellnf	<b>Seven Batten42</b>		Display Model Name	
SoftWare	≥ V2.02		Software Versions (greater than or equal to)		

**Supports Software Versions: ≥ 2.02**

Features are subject to change without any prior written notice.

MENU	SUB MENU	OPTIONS / VALUES (Default Settings in BOLD)	DESCRIPTION		
Manual		Strobe	<b>000</b> - 255	Set DMX Values Manually	
		Dimmer	<b>000</b> - 255		
		DimFine	<b>000</b> - 255		
		DimMode	<b>000</b> - 255		
		Red1	<b>000</b> - 255		
		Green1	<b>000</b> - 255		
		Blue1	<b>000</b> - 255		
		Amber1	<b>000</b> - 255		
		White1	<b>000</b> - 255		
		Amber1	<b>000</b> - 255		
		Lime1	<b>000</b> - 255		
		UV1	<b>000</b> - 255		
		Red2	<b>000</b> - 255		
		Green2	<b>000</b> - 255		
		Blue2	<b>000</b> - 255		
		Amber2	<b>000</b> - 255		
		White2	<b>000</b> - 255		
		Amber2	<b>000</b> - 255		
		Lime2	<b>000</b> - 255		
		UV2	<b>000</b> - 255		
		▼	▼		
		Red5	<b>000</b> - 255		
		Green5	<b>000</b> - 255		
		Blue5	<b>000</b> - 255		
		Amber5	<b>000</b> - 255		
		White5	<b>000</b> - 255		
		Amber5	<b>000</b> - 255		
		Lime5	<b>000</b> - 255		
		UV5	<b>000</b> - 255		
		Red6	<b>000</b> - 255		
		Green6	<b>000</b> - 255		
		Blue6	<b>000</b> - 255		
		Amber6	<b>000</b> - 255		
White6	<b>000</b> - 255				
Amber6	<b>000</b> - 255				
Lime6	<b>000</b> - 255				
UV6	<b>000</b> - 255				
Chase	<b>000</b> - 255				
Chase.Sp	<b>000</b> - 255				
Chase.F	<b>000</b> - 255				
Macro	<b>000</b> - 255				
Calibrat	Password	<b>050</b>	Enter Password to Access Calibration Menu <b>NOTE: ONLY QUALIFIED TECHNICIANS SHOULD PERFORM THIS FUNCTION!</b>		

## FLIP

The Flip mode can be selected from the system menu, which flips the starting PIXEL ZONE location and sequence from one end of the batten to the opposite end. This feature makes it easy to configure the pixel zones of multiple battens to be the same regardless of their installation orientation. See diagram below.

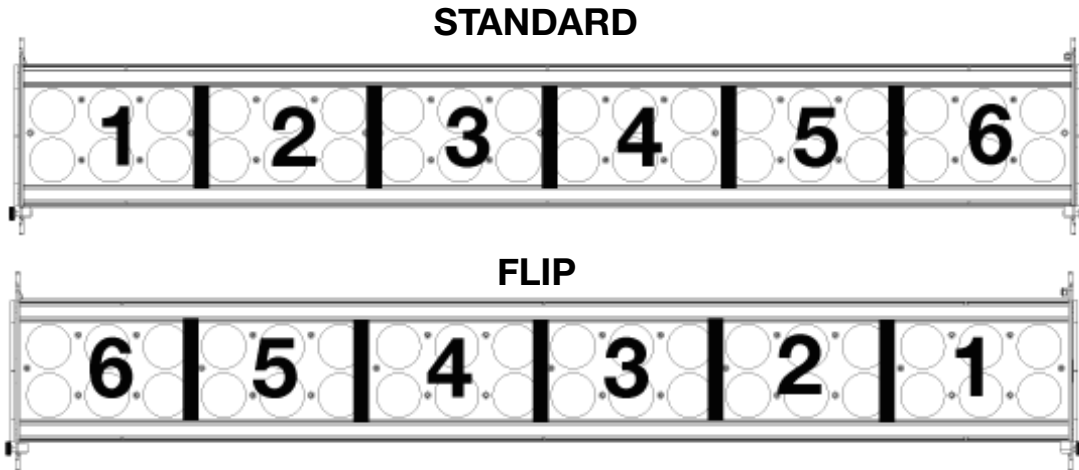



# DMX CHANNEL FUNCTIONS AND VALUES

ELATION SEVEN BATTEN 42 | DMX Channel Values / Functions (50 DMX Channels)

Supports Software Versions: ≥ 2.02

Features subject to change without any prior written notice.

**\*PIXEL/ZONE control depends on flip system menu setting and fixture orientation.**

**MODE / CHANNEL**

RGB 3CH	RGBSeven 3CH	8Bit 7CH	16Bit 14CH	Master 15CH	Cells 42CH	MastCell 50CH	HSI 4CH	HIS Mast 10CH	HIS Cell 26CH	VALUE	FUNCTION				
				1		1		1	1		SHUTTER / STROBE				
													0-31	LED OFF	
													32-63	LED ON	
													64-95	Strobe Effect SLOW to FAST	
													96-127	LED ON	
													128-159	Strobe Pulse Effect SLOW to FAST	
													160-191	LED ON	
													192-223	Random Strobe Effect SLOW to FAST	
													224-255	LED ON	
				2		2	1	2	2		MASTER DIMMER / INTENSITY				
														0-255	0-100%
				3		3	2	3	3		MASTER DIMMER / INTENSITY FINE				
														0-255	0-100%
				4		4		4	4		DIMMING MODES				
													0-20	STANDARD	
													21-40	STAGE	
													41-60	TV	
													61-80	ARCHITECTURAL	
													81-100	THEATER	
													101-120	STAGE 2	
									121-255	DEFAULT TO UNIT SETTING					
				5		5		5	5		PROGRAM MACROS				
														0-19	NO FUNCTION
														20-39	PROGRAM 01
														40-59	PROGRAM 02
														60-79	PROGRAM 03
														80-99	PROGRAM 04
														100-119	PROGRAM 05
														120-139	PROGRAM 06
														140-159	PROGRAM 07
														160-179	PROGRAM 08
														180-199	PROGRAM 09
														200-219	PROGRAM 10
														220-239	PROGRAM 11
										240-255	PROGRAM 12				
				6		6		6	6		PROGRAM MACRO SPEED				
													0-255	Program Macro SPEED SLOW to FAST	
				7		7		7	7		PROGRAM MACRO FADE				
													0-255	Program Macro FADE SLOW to FAST	

Features subject to change without any prior written notice.

**\*PIXEL/ZONE control depends on flip system menu setting and fixture orientation.**

MODE / CHANNEL										VALUE	FUNCTION
RGB 3CH	RGBSeven 3CH	8Bit 7CH	16Bit 14CH	Master 15CH	Cells 42CH	MastCell 50CH	HSI 4CH	HIS Mast 10CH	HIS Cell 26CH		
											<b>COLOR MACROS</b>
											1-4 Color Macro 01
											5-8 Color Macro 02
											9-12 Color Macro 03
											13-16 Color Macro 04
											17-20 Color Macro 05
											21-24 Color Macro 06
											25-28 Color Macro 07
											29-32 Color Macro 08
											33-36 Color Macro 09
											37-40 Color Macro 10
											41-44 Color Macro 11
											45-48 Color Macro 12
											49-52 Color Macro 13
											53-56 Color Macro 14
				8		8		8	8		57-60 Color Macro 15
											61-64 Color Macro 16
											65-68 Color Macro 17
											69-72 Color Macro 18
											73-76 Color Macro 19
											77-80 Color Macro 20
											81-84 Color Macro 21
											85-88 Color Macro 22
											89-92 Color Macro 23
											93-96 Color Macro 24
											97-100 Color Macro 25
											101-104 Color Macro 26
											105-108 Color Macro 27
											109-112 Color Macro 28
											113-116 Color Macro 29
											117-120 Color Macro 30
											121-124 Color Macro 31
											125-128 Color Macro 32

Features subject to change without any prior written notice.

**\*PIXEL/ZONE control depends on flip system menu setting and fixture orientation.**

MODE / CHANNEL										VALUE	FUNCTION
RGB 3CH	RGBSeven 3CH	8Bit 7CH	16Bit 14CH	Master 15CH	Cells 42CH	MastCell 50CH	HSI 4CH	HIS Mast 10CH	HIS Cell 26CH		
										129-132	Color Macro 33
										133-136	Color Macro 34
										137-140	Color Macro 35
										141-144	Color Macro 36
										145-148	Color Macro 37
										149-152	Color Macro 38
										153-156	Color Macro 39
										157-160	Color Macro 40
										161-164	Color Macro 41
										165-168	Color Macro 42
										169-172	Color Macro 43
										173-176	Color Macro 44
										177-180	Color Macro 45
										181-184	Color Macro 46
										185-188	Color Macro 47
				8		8		8	8	189-192	Color Macro 48
										193-196	Color Macro 49
										197-200	Color Macro 50
										201-204	Color Macro 51
										205-208	Color Macro 52
										209-212	Color Macro 53
										213-216	Color Macro 54
										217-220	Color Macro 55
										221-224	Color Macro 56
										225-228	Color Macro 57
										229-232	Color Macro 58
										233-236	Color Macro 59
										237-240	Color Macro 60
										241-244	Color Macro 61
										245-248	Color Macro 62
										249-252	Color Macro 63
										253-255	Color Macro 64

Features subject to change without any prior written notice.

**\*PIXEL/ZONE control depends on flip system menu setting and fixture orientation.**

MODE / CHANNEL										VALUE	FUNCTION
RGB 3CH	RGBSeven 3CH	8Bit 7CH	16Bit 14CH	Master 15CH	Cells 42CH	MastCell 50CH	HSI 4CH	HIS Mast 10CH	HIS Cell 26CH		
							3	9		0-255	HUE - ALL PIXELS / ZONES 0-100%
							4	10		0-255	SATURATION - ALL PIXELS / ZONES 0-100%
1	1	1	1	9						0-255	RED - ALL PIXELS / ZONES 0-100%
			2							0-255	RED FINE - ALL PIXELS / ZONES 16-bit FINE Adjustment
2	2	2	3	10						0-255	GREEN - ALL PIXELS / ZONES 0-100%
			4							0-255	GREEN FINE - ALL PIXELS / ZONES 16-bit FINE Adjustment
3	3	3	5	11						0-255	BLUE - ALL PIXELS / ZONES 0-100%
			6							0-255	BLUE FINE - ALL PIXELS / ZONES 16-bit FINE Adjustment
		4	7	12						0-255	WHITE - ALL PIXELS / ZONES 0-100%
			8							0-255	WHITE FINE - ALL PIXELS / ZONES 16-bit FINE Adjustment
		5	9	13						0-255	AMBER - ALL PIXELS / ZONES 0-100%
			10							0-255	AMBER FINE - ALL PIXELS / ZONES 16-bit FINE Adjustment
		6	11	14						0-255	LIME - ALL PIXELS / ZONES 0-100%
			12							0-255	LIME FINE - ALL PIXELS / ZONES 16-bit FINE Adjustment
		7	13	15						0-255	UV - ALL PIXELS / ZONES 0-100%
			14							0-255	UV - ALL PIXELS / ZONES 16-bit FINE Adjustment

Features subject to change without any prior written notice.

**\*PIXEL/ZONE control depends on flip system menu setting and fixture orientation.**

MODE / CHANNEL										VALUE	FUNCTION
RGB 3CH	RGBSeven 3CH	8Bit 7CH	16Bit 14CH	Master 15CH	Cells 42CH	MastCell 50CH	HSI 4CH	HIS Mast 10CH	HIS Cell 26CH		
									9	0-255	HUE - ZONE 1 0-100%
									10	0-255	SATURATION - ZONE 1 0-100%
									11	0-255	INTENSITY - ZONE 1 0-100%
					1	9				0-255	RED - ZONE 1 0-100%
					2	10				0-255	GREEN - ZONE 1 0-100%
					3	11				0-255	BLUE - ZONE 1 0-100%
					4	12				0-255	WHITE - ZONE 1 0-100%
					5	13				0-255	AMBER - ZONE 1 0-100%
					6	14				0-255	LIME - ZONE 1 0-100%
					7	15				0-255	UV - ZONE 1 0-100%
					8	16				0-255	RED - ZONE 2 0-100%
									12	0-255	HUE - ZONE 2 0-100%
									13	0-255	SATURATION - ZONE 2 0-100%
									14	0-255	INTENSITY - ZONE 2 0-100%
					9	17				0-255	GREEN - ZONE 2 0-100%
					10	18				0-255	BLUE - ZONE 2 0-100%
					11	19				0-255	WHITE - ZONE 2 0-100%
					12	20				0-255	AMBER - ZONE 2 0-100%
					13	21				0-255	LIME - ZONE 2 0-100%
					14	22				0-255	UV - ZONE 2 0-100%

Features subject to change without any prior written notice.

**\*PIXEL/ZONE control depends on flip system menu setting and fixture orientation.**

MODE / CHANNEL										VALUE	FUNCTION
RGB 3CH	RGBSeven 3CH	8Bit 7CH	16Bit 14CH	Master 15CH	Cells 42CH	MastCell 50CH	HSI 4CH	HIS Mast 10CH	HIS Cell 26CH		
									15	0-255	HUE - ZONE 3 0-100%
									16	0-255	SATURATION - ZONE 3 0-100%
									17	0-255	INTENSITY - ZONE 3 0-100%
					15	23				0-255	RED - ZONE 3 0-100%
					16	24				0-255	GREEN - ZONE 3 0-100%
					17	25				0-255	BLUE - ZONE 3 0-100%
					18	26				0-255	WHITE - ZONE 3 0-100%
					19	27				0-255	AMBER - ZONE 3 0-100%
					20	28				0-255	LIME - ZONE 3 0-100%
					21	29				0-255	UV - ZONE 3 0-100%
									18	0-255	HUE - ZONE 4 0-100%
									19	0-255	SATURATION - ZONE 4 0-100%
									20	0-255	INTENSITY - ZONE 4 0-100%
					22	30				0-255	RED - ZONE 4 0-100%
					23	31				0-255	GREEN - ZONE 4 0-100%
					24	32				0-255	BLUE - ZONE 4 0-100%
					25	33				0-255	WHITE - ZONE 4 0-100%
					26	34				0-255	AMBER - ZONE 4 0-100%
					27	35				0-255	LIME - ZONE 4 0-100%
					28	36				0-255	UV - ZONE 4 0-100%

Features subject to change without any prior written notice.

**\*PIXEL/ZONE control depends on flip system menu setting and fixture orientation.**

MODE / CHANNEL										VALUE	FUNCTION
RGB 3CH	RGBSeven 3CH	8Bit 7CH	16Bit 14CH	Master 15CH	Cells 42CH	MastCell 50CH	HSI 4CH	HIS Mast 10CH	HIS Cell 26CH		
									21	0-255	HUE - ZONE 5 0-100%
									22	0-255	SATURATION - ZONE 5 0-100%
									23	0-255	INTENSITY - ZONE 5 0-100%
					29	37				0-255	RED - ZONE 5 0-100%
					30	38				0-255	GREEN - ZONE 5 0-100%
					31	39				0-255	BLUE - ZONE 5 0-100%
					32	40				0-255	WHITE - ZONE 5 0-100%
					33	41				0-255	AMBER - ZONE 5 0-100%
					34	42				0-255	LIME - ZONE 5 0-100%
					35	43				0-255	UV - ZONE 5 0-100%
									24	0-255	HUE - ZONE 6 0-100%
									25	0-255	SATURATION - ZONE 6 0-100%
									26	0-255	INTENSITY - ZONE 6 0-100%
					36	44				0-255	RED - ZONE 6 0-100%
					37	45				0-255	GREEN - ZONE 6 0-100%
					38	46				0-255	BLUE - ZONE 6 0-100%
					39	47				0-255	WHITE - ZONE 6 0-100%
					40	48				0-255	AMBER - ZONE 6 0-100%
					41	49				0-255	LIME - ZONE 6 0-100%
					42	50				0-255	UV - ZONE 6 0-100%

# **S P E C I F I C A T I O N S**

## **SOURCE**

36 25W 7-in-1 RGBAW + Lime +UV LEDs

50,000 Hour Average LED Life\*

\*May vary depending on several factors including but not limited to:  
Environmental Conditions, Power/Voltage, Usage Patterns (On-Off Cycling), Control, and Dimming.

## **EFFECTS**

6 Pixel Mapping Zones with Pixel Flip Mode

Special RGB + Channel Mode with Dynamic White, Amber, Lime, UV Added Automatically

Smooth Color Mixing, Internal Programs and 64 Color Macros

High Speed Electronic Shutter and Strobe

16Bit Dimming and Variable Dimming Curve Modes

## **CONTROL / CONNECTIONS**

10 DMX Channel Modes (50 total channels)

Adjustable Refresh Rate (900-1500, 25,000 Hz)

Adjustable Gamma Brightness (2.0, 2.2, 2.4, 2.8)

4 Button Control Panel / LCD Menu Display

DMX, RDM, Kling-NET, and Art-NET Protocol Support

5pin DMX and RJ45 etherCON In/Out

Seetronic Powerkon In/Out

## **SIZE / WEIGHT**

Length: 42.0" (1066.8mm)

Width: 4.5" (114.3mm)

Vertical Height: 9.0" (228.6mm)

Weight: 39.0 lbs. (17.7kg)

## **ELECTRICAL / THERMAL**

AC 100-240V - 50/60Hz

614W Max Power Consumption

14°F to 113°F (-10°C to 45°C)

## **APPROVALS / RATINGS**

CE | IP20

Specifications and improvements in the design of this unit and this manual are subject to change without any prior written notice.



## **FCC STATEMENT**

This device complies with Part 15 of the FCC Rules. Operation is subject to the following two conditions: (1) this device may not cause harmful interference, and (2) this device must accept any interference received, including interference that may cause undesired operation.

## **FCC RADIO FREQUENCY INTERFERENCE WARNINGS & INSTRUCTIONS**

This product has been tested and found to comply with the limits as per Part 15 of the FCC Rules. These limits are designed to provide reasonable protection against harmful interference in a residential installation. This device uses and can radiate radio frequency energy and, if not installed and used in accordance with the included instructions, may cause harmful interference to radio communications. However, there is no guarantee that interference will not occur in a particular installation. If this device does cause harmful interference to radio or television reception, which can be determined by turning the device off and on, the user is encouraged to try to correct the interference by one or more of the following methods:

- Reorient or relocate the device.
- Increase the separation between the device and the receiver.
- Connect the device to an electrical outlet on a circuit different from which the radio receiver is connected.
- Consult the dealer or an experienced radio/TV technician for help.

# DIMENSIONAL DRAWINGS

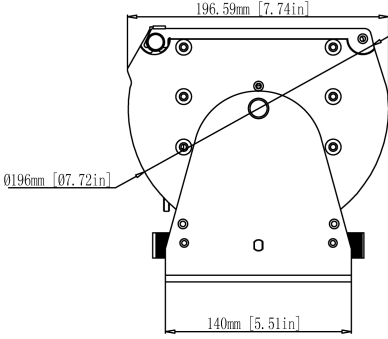
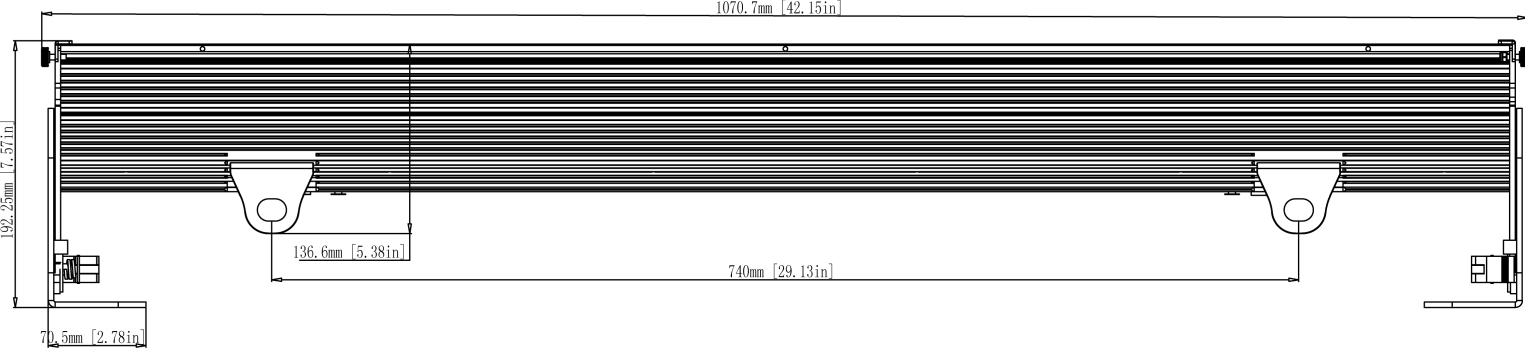
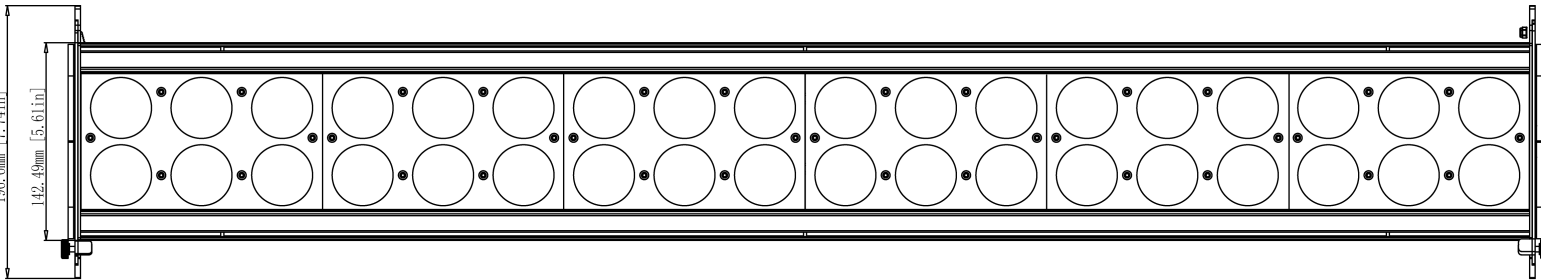

## OPTIONAL ACCESSORIES

ORDER CODE	ITEM
TRIGGER CLAMP	Heavy Duty Wrap Around Hook Style Clamp
SCABLE60	Safety Cable 24" (610mm) 60 lbs. (27kg) Rating
STR527	5 ft. (1.5m) IP65 Seetronic 5pin DMX Cable
NEU088	3 ft. (1m) powerCON TRUE1 Power Link Cable
	Additional Cable Lengths Available

