

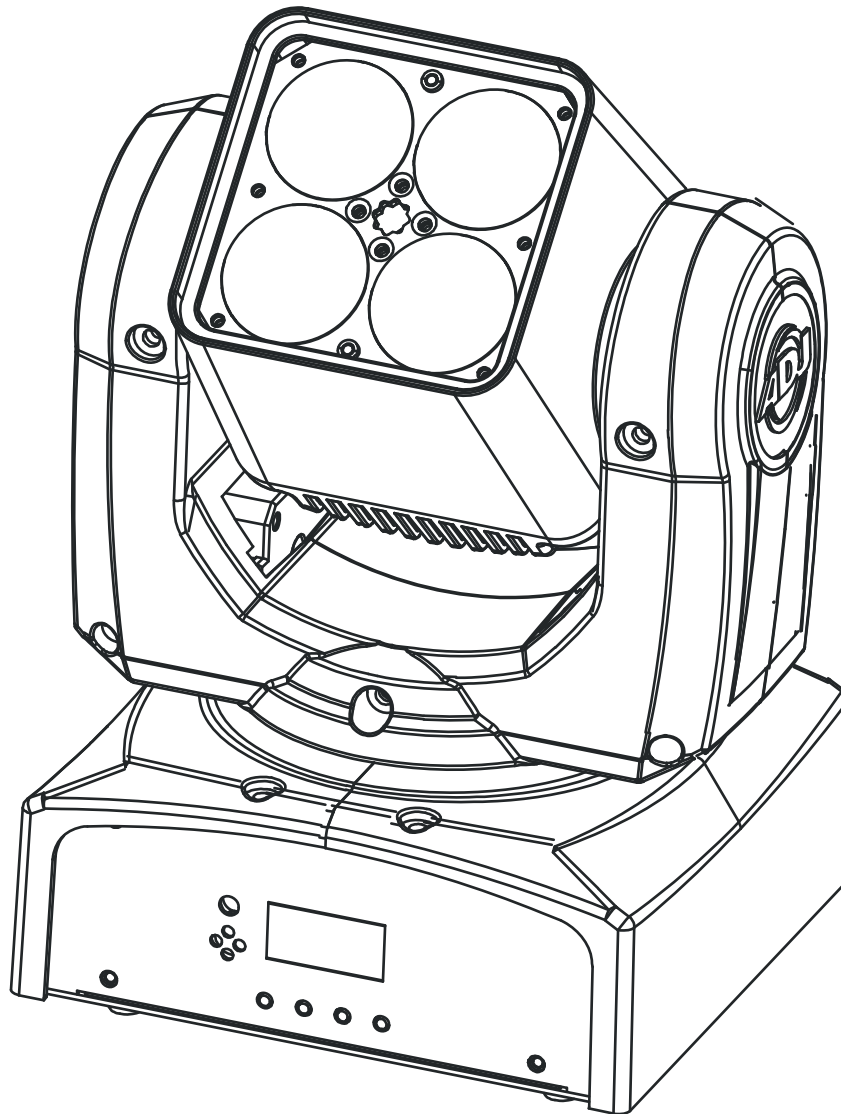

INNO POCKET Z4



User Instructions

©2020 ADJ Products, LLC all rights reserved. Information, specifications, diagrams, images, and instructions herein are subject to change without notice. ADJ Products, LLC logo and identifying product names and numbers herein are trademarks of ADJ Products, LLC. Copyright protection claimed includes all forms and matters of copyrightable materials and information now allowed by statutory or judicial law or hereinafter granted. Product names used in this document may be trademarks or registered trademarks of their respective companies and are hereby acknowledged. All non-ADJ Products, LLC brands and product names are trademarks or registered trademarks of their respective companies.

ADJ Products, LLC and all affiliated companies hereby disclaim any and all liabilities for property, equipment, building, and electrical damages, injuries to any persons, and direct or indirect economic loss associated with the use or reliance of any information contained within this document, and/or as a result of the improper, unsafe, insufficient and negligent assembly, installation, rigging, and operation of this product.

Europe Energy Saving Notice

Energy Saving Matters (EuP 2009/125/EC)

Saving electric energy is a key to help protecting the environment. Please turn off all electrical products when they are not in use. To avoid power consumption in idle mode, disconnect all electrical equipment from power when not in use. Thank you!

Unpacking: Thank you for purchasing the Inno Pocket Z4 by ADJ Products, LLC. Every Inno Pocket Z4 has been thoroughly tested and has been shipped in perfect operating condition. Carefully check the shipping carton for damage that may have occurred during shipping. If the carton appears to be damaged, carefully inspect your fixture for any damage and be sure all equipment necessary to operate the unit has arrived intact. In the event damage has been found or parts are missing, please contact our toll free customer support number for further instructions. Please do not return this unit to your dealer without contacting customer support first.

Introduction: The Inno Pocket Z4 is a DMX intelligent, zooming, moving head, mini LED fixture. The Inno Pocket Z4 can operate as a stand alone fixture or in a Primary/Secondary set up. The Inno Pocket Z4 has three operating modes; sound active mode, show mode, DMX controlled. This fixture is suitable for theaters, studios, retail stores, and other similar locations. *For best results use fog or special effects smoke to enhance the beams projections.*

Customer Support: ADJ Products, LLC provides a toll free customer support line, to provide help and to answer any question should you encounter problems during your set up or initial operation. You may also visit us on the web at www.adj.com for any comments or suggestions. Service Hours are Monday through Friday 8:00 a.m. to 4:30 p.m. Pacific Standard Time.

Voice: (800) 322-6337

Phone (323) 582-2941

E-mail: support@americandj.com

Warning! To prevent or reduce the risk of electrical shock or fire, do not expose this unit to rain or moisture.

Warning! *This may cause severe eye damage. Avoid looking directly into the light source at all times!*

To optimize the performance of this product, please read these operating instructions carefully to familiarize yourself with the basic operations of this unit. These instructions contain important safety information regarding the use and maintenance of this unit. Please keep this manual with the unit, for future reference.

- DMX-512 Protocol Compatible (3 DMX Channel Modes: 16 Channels, 19 Channels, & 22 Channels)
- 3 Operating Modes - Sound Active, Show Mode, & DMX Control
- 5 Dimmer Curves (Standard, Stage, TV, Architectural, & Theatre)
- Internal Microphone
- Digital Display for Address and Function Setting
- 4 Preprogrammed Shows
- UC IR Compatible (Not Included)

The Inno Pocket Z4 carries a 2 year (730 days) limited warranty. Please fill out the enclosed warranty card to validate your purchase and warranty. You may also register your product online at www.adj.com. All returned service items whether under warranty or not, must be freight pre-paid, and accompany a return authorization (R.A.) number. If the unit is under warranty you must provide a copy of your proof of purchase invoice. Please contact ADJ Products, LLC customer support for a R.A. number.

Caution! There are no user serviceable parts inside this unit. Do not attempt any repairs yourself, doing so will void your warranty. In the unlikely event your unit may require service please contact ADJ Products, LLC.

During operation the housing may become extremely hot. Avoid touching the unit with bare hands while in use.

ADJ Products, LLC will not accept any liability for any resulting damages caused by the non-observance of this manual or any unauthorized modification to this unit.

For Your Own Personal Safety, Please Read and Understand This Manual Completely Before You Attempt To Install Or Operate This Unit!

- To reduce the risk of electrical shock or fire, do not expose this unit rain or moisture
- Do not spill water or other liquids into or on to your unit.
- Be sure that the local power outlet match that of the required voltage for your unit.
- Do not attempt to operate this unit if the power cord has been frayed or broken.
- Do not attempt to remove or break off the ground prong from the electrical cord. This prong is used to reduce the risk of electrical shock and fire in case of an internal short.
- Disconnect from main power before making any type of connection.
- Do not remove the cover under any conditions. There are no user serviceable parts inside.
- Never operate this unit when it's cover is removed.
- Always be sure to mount this unit in an area that will allow proper ventilation. Allow about 6" (15cm) between this device and a wall.
- Do not attempt to operate this unit, if it becomes damaged.
- This unit is intended for indoor use only, use of this product outdoors voids all warranties.
- Always mount this unit in safe and stable matter.
- Power-supply cords should be routed so that they are not likely to be walked on or pinched by items placed upon or against them, paying particular attention to cords at plugs, convenience receptacles, and the point where they exit from the appliance.
- • Cleaning -The fixture should be cleaned only as recommended by the manufacturer. See page 29 for cleaning details.
- Heat -This fixture should be situated away from heat sources such as radiators, heat registers, stoves, or other appliances (including amplifiers) that produce heat.
- The fixture should be serviced by qualified service personnel when:
 - A. Objects have fallen, or liquid has been spilled into the appliance.
 - B. The appliance has been exposed to rain or water.
 - C. The appliance does not appear to operate normally or exhibits a marked change in performance.

When installing the unit, the trussing or area of installation must be able to hold 10 times the weight without any deformation. When installing the unit must be secured with a secondary safety attachment, e.g. and appropriate safety cable. Never stand directly below the unit when mounting, removing, or servicing the unit.

Overhead mounting requires extensive experience, including calculating working load limits, installation material being used, and periodic safety inspection of all installation material and unit. If you lack these qualifications, do not attempt the installation yourself. The installation should be checked by a skilled person once a year.

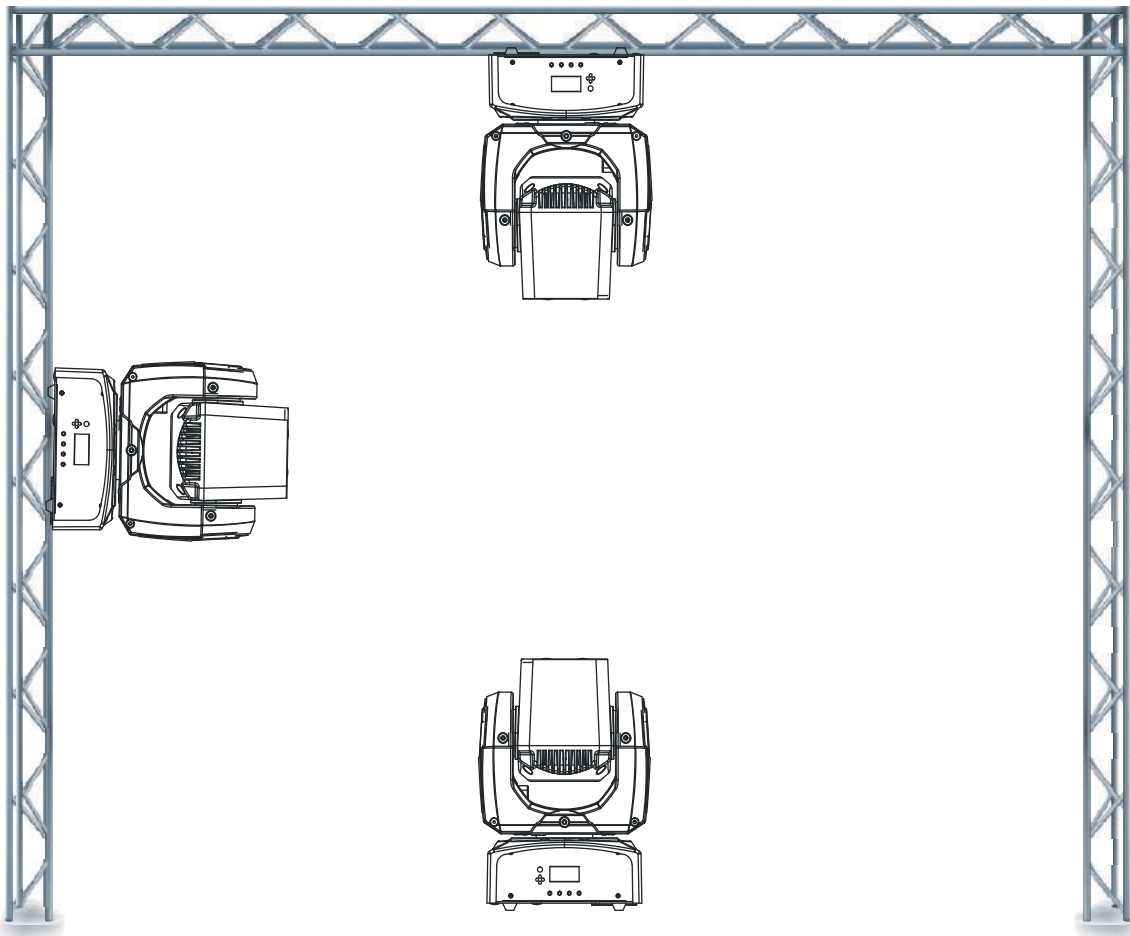

The Inno Pocket Z4 is fully operational in three different mounting positions, hanging upside-down from a ceiling, set on a flat level surface, or on its side attached to trussing. Be sure this fixture is kept at least 0.5m away from any flammable materials (decoration etc.). Always use and install the supplied safety cable as a safety measure to prevent accidental damage and/or injury in the event the clamp fails (see next page).

NOTICE: The suitable environmental temperature for this lighting fixture is between -25° C to 45° C. Do not place this lighting fixture in an environment where the temperatures are under or above the temperatures stated above. This will allow the fixture to run at its best and help prolong the fixture life.

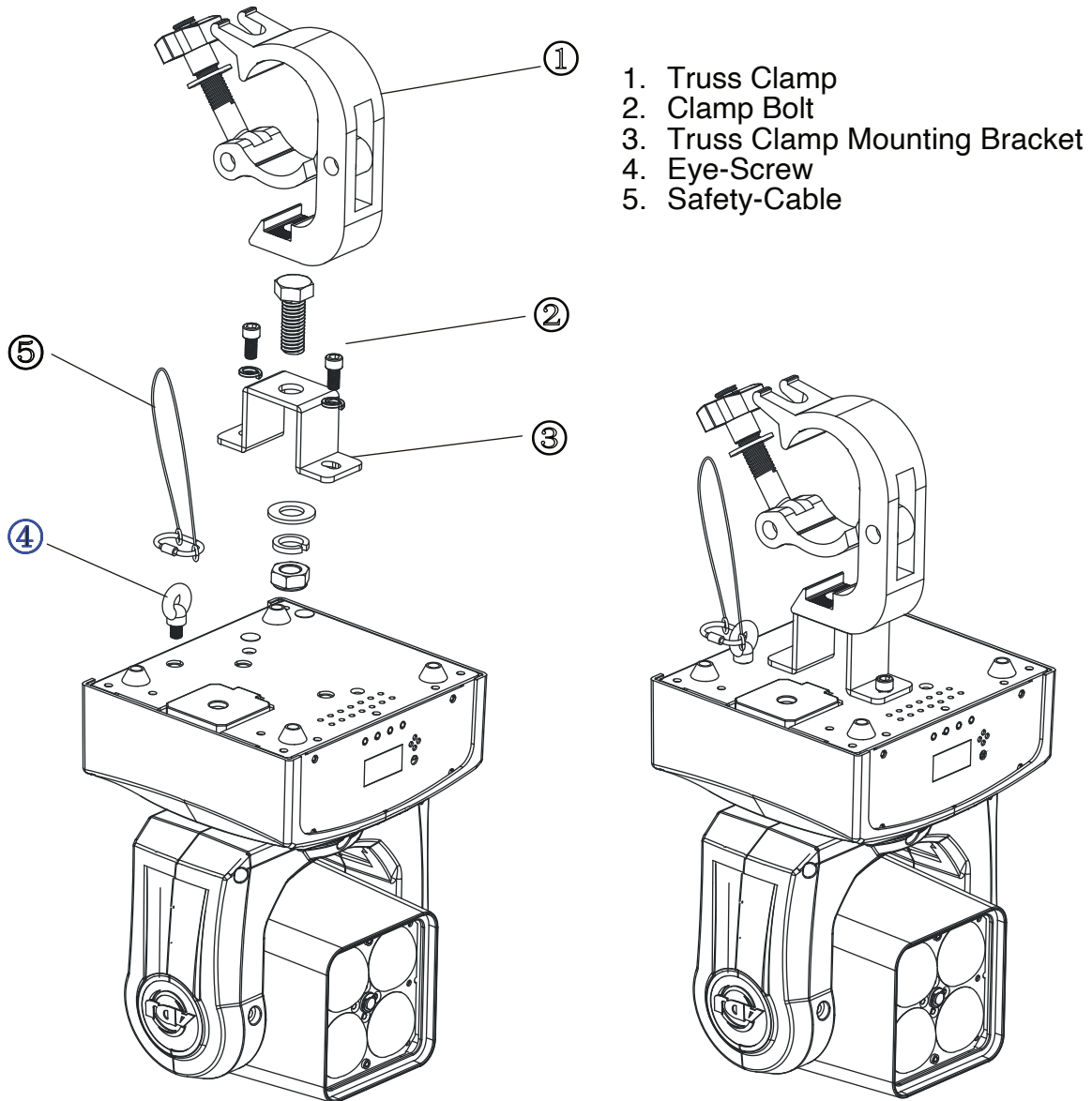

1. Truss Clamp
2. Clamp Bolt
3. Truss Clamp Mounting Bracket
4. Eye-Screw
5. Safety-Cable

Screw one clamp via a M12 screw and nut to the included bracket. Attach the bracket using the included screws to the bottom of the Inno Pocket Z4. Attach the eyebolt to the bottom of the base and pull the safety-cable through the screw and over the trussing system or a safe fixation spot. Insert the end in the carbine and tighten the safety screw.

Power Supply: The ADJ Inno Pocket Z4 contains a automatic voltage switch, which will auto sense the voltage when it is plugged into the power source. With this switch there is no need to worry about the correct power voltage, this unit can be plugged in anywhere.

DMX-512: DMX is short for Digital Multiplex. This is a universal protocol used by most lighting and controller manufactures as a form of communication between intelligent fixtures and controllers. A DMX controller sends DMX data instructions from the controller to the fixture. DMX data is sent as serial data that travels from fixture to fixture via the DATA “IN” and DATA “OUT” XLR terminals located on all DMX fixtures (most controllers only have a DATA “OUT” terminal).

DMX Linking: DMX is a language allowing all makes and models of different manufactures to be linked together and operate from a single controller, as long as all fixtures and the controller are DMX compliant. To ensure proper DMX data transmission, when using several DMX fixtures try to use the shortest cable path possible. The order in which fixtures are connected in a DMX line does not influence the DMX addressing. For example; a fixture assigned a DMX address of 1 may be placed anywhere in a DMX line, at the beginning, at the end, or anywhere in the middle. Therefore, the first fixture controlled by the controller could be the last fixture in the chain. When a fixture is assigned a DMX address of 1, the DMX controller knows to send DATA assigned to address 1 to that unit, no matter where it is located in the DMX chain.

Data Cable (DMX Cable) Requirements (For DMX and primary/Secondary Operation): The Inno Pocket Z4 can be controlled via DMX-512 protocol. The Inno Pocket Z4 three DMX channel modes; 16 channel mode, 19 channel mode, & 22 channel mode. The DMX address is set electronically using the controls on the front panel of the unit. Your unit and your DMX controller require an approved DMX-512 110 Ohm Data cable for data input and data output (Figure 1). We recommend Accu-Cable DMX cables. If you are making your own cables, be sure to use standard 110-120



Figure 1

Ohm shielded cable (This cable may be purchased at almost all professional sound and lighting stores). Your cables should be made with male and female XLR connector on either end of the cable. Also remember that DMX cable must be daisy chained and cannot be split.

Notice: Be sure to follow figures two and three when making your own cables. Do not use the ground lug on the XLR connector. Do not connect the cable's shield conductor to the ground lug or allow the shield conductor to come in contact with the XLR's outer casing. Grounding the shield could cause a short circuit and erratic behavior.

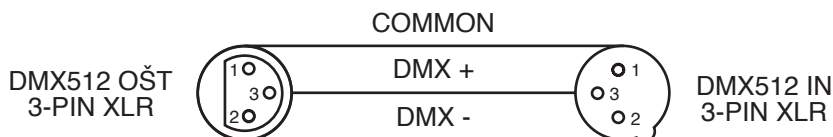

Figure 2

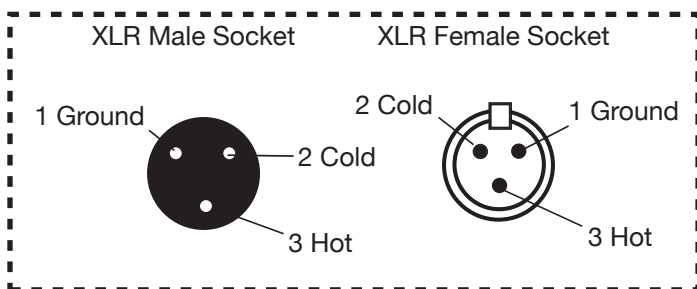
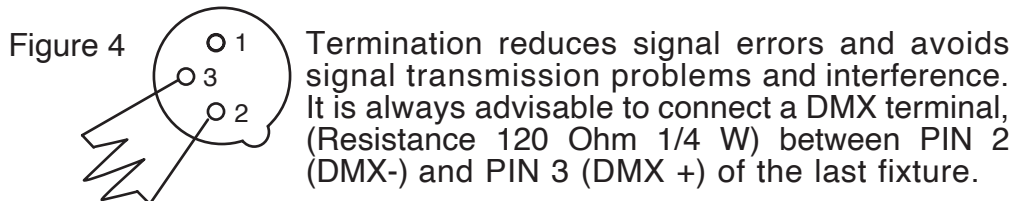

Figure 3

XLR Pin Configuration
Pin 1 = Ground
Pin 2 = Data Compliment (negative)
Pin 3 = Data True (positive)

Special Note: Line Termination. When longer runs of cable are used, you may need to use a terminator on the last unit to avoid erratic behavior. A terminator is a 110-120 ohm 1/4 watt resistor which is connected between pins 2 and 3 of a male XLR connector (DATA + and DATA -). This unit is inserted in the female XLR connector of the last unit in your daisy chain to terminate the line. Using a cable terminator (ADJ part number Z-DMX/T) will decrease the possibilities of erratic behavior.



5-Pin XLR DMX Connectors. Some manufactures use 5-pin DMX-512 data cables for DATA transmission in place of 3-pin. 5-pin DMX fixtures may be implemented in a 3-pin DMX line. When inserting standard 5-pin data cables in to a 3-pin line a cable adapter must be used, these adapters are readily available at most electric stores. The chart below details a proper cable conversion.

3-Pin XLR to 5-Pin XLR Conversion		
Conductor	3-Pin XLR Female (Out)	5-Pin XLR Male (In)
Ground/Shield	Pin 1	Pin 1
Data Compliment (- signal)	Pin 2	Pin 2
Data True (+ signal)	Pin 3	Pin 3
Not Used		Pin 4 - Do Not Use
Not Used		Pin 5 - Do Not Use

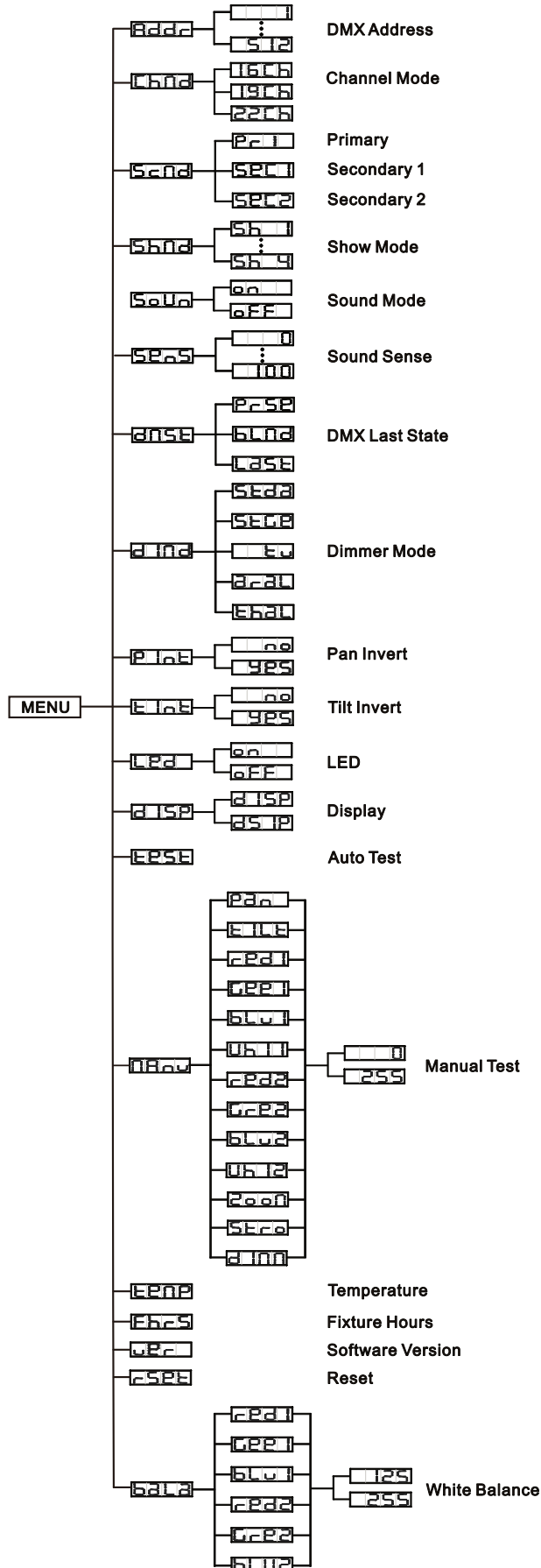

System Menu: When making adjustments press **ENTER** to confirm your setup then press and hold the **MENU** button for at least 3 seconds. To exit without making any adjustments press the **MENU** button. The display will lock after 30 seconds, press the **MENU** button for 3 seconds to unlock.

ADDR - DMX Address Setting.

1. Press the either the **MENU**, **UP**, or **DOWN** buttons until “**ADDR**” is displayed, press **ENTER**.
2. The current address will now be displayed and flashing. Press the **UP** or **DOWN** buttons to find your desired address. Press **ENTER** to set your desired DMX address.

CHND - This will let select your desired DMX channel mode.

1. Press the either the **MENU** button until “**CHND**” is displayed, press **ENTER**. The current DMX channel mode will be displayed.
2. Press the **UP** or **DOWN** buttons to find your desired DMX channel mode and press **ENTER** to confirm and exit.

ScND - This will let you set unit as a Primary or Secondary in a primary/Secondary configuration.

1. Press the **MENU** button until “**ScND**” is displayed, press **ENTER**. Either “**Pr1**”, “**SEC1**”, or “**SEC2**” will be displayed.
2. Press the **UP** or **DOWN** buttons until your desired setting is displayed, press **ENTER** to confirm.

NOTE: In a Primary/Secondary configuration you can set one fixture to Primary and then set the next fixture to “**SEC2**”, the fixtures will now have contrast movement to each other.

SHND - Show modes 1-4. Show mode can run with or without sound active mode active.

1. Press the MENU button until “**SHND**” is displayed, press ENTER.
2. “**Sh X**” will now be displayed, “**X**” representing a number between 1-4. Use the UP or DOWN buttons to find your desired show.
3. When you have found your desired show press ENTER, then press and hold the MENU button for at least 3 seconds to activate.

SOUN - Sound Active mode.

1. Press the MENU button until “**SOUN**” is displayed, press ENTER.
2. The display will show either “**ON**” or “**OFF**”. Press the UP or DOWN buttons to select “**ON**” to activate sound active mode, or “**OFF**” to deactivate sound active mode.
3. Press ENTER to confirm.

SENS - In this mode you can adjust the sound sensitivity.

1. Press the MENU button until “**SENS**” is displayed, press **ENTER**.
2. A number between 0-100 will be displayed. Press the **UP** or **DOWN** buttons to adjust the sound sensitivity. 0 being the least sensitive, and 100 being the most sensitive.
3. When you have found your desired setting press **ENTER** to confirm.

DNST - This mode can be used as a precaution mode, that in case the DMX signal is lost, interrupted, or power is lost, the operating mode chosen in the setup is the running mode the fixture will go into when the DMX signal is lost. You can also set this as the operating mode you would like the unit to return to when power is applied.

1. Press the MENU button until “**DNST**” is displayed, and either “**PrSE**”, “**BLND**”, or “**LAST**” will be displayed beneath.
2. Press **ENTER** and the bottom choice will begin to flash. Use the **UP** or **DOWN** buttons to choose an operating mode you would like the unit to start up in when power is applied or the DMX signal is lost.
 - **LAST** - If the DMX signal is lost the fixture will stay in the last DMX setting. If power is applied and this mode is set, the unit will automatically go into the last DMX set up.
 - **PrSE** (Primary Secondary) - If the DMX signal is lost or power is applied, the unit will automatically go into Primary Secondary mode and run a built-in show.
 - **BLND** (Blackout) - If the DMX signal is lost or interrupted, the unit will automatically go into stand by mode.
3. Press **ENTER** to confirm your desired set up.

DIND - This will let select your desired dimmer curve.

1. Press the **MENU** button until “**DIND**” is displayed, and press **ENTER**. 1 of 5 dimmer curves will be displayed. “**STDA**” (standard), “**STGE**” (stage), “**TV**” (TV), “**ARAL**” (Architectural), or “**THAL**” (Theatre). See the dimmer curve chart on page 28 for more info.
2. Press the **UP** or **DOWN** buttons to find your desired dimmer curve and press **ENTER** to confirm and exit.

PINT - Pan Inversion

1. Press the MENU button until “**PINT**” is displayed, press ENTER. Either “**Yes**” or “**No**” will be displayed.
2. To activate the Pan inversion press the **UP** or **DOWN** buttons until “**Yes**” is displayed, press **ENTER** to confirm. To deactivate Pan inversion, select “**No**” and press Enter.

TINT - Tilt Inversion

1. Press the MENU button until “**TINT**” is displayed, press ENTER. Either “**Yes**” or “**No**” will be displayed.
2. To activate the tilt inversion press the **UP** or **DOWN** buttons until “**Yes**” is displayed, press **ENTER** to confirm. To deactivate tilt inversion, select “**No**” and press Enter.

LED - With this function you can have the display back- light turn off after 10 seconds.

1. Press the MENU button until “**LED**” is displayed, press **ENTER**.
2. The display will show either “**ON**” or “**OFF**”. Press the UP or DOWN buttons to select “**ON**” to keep the LED display on at all times, or “**OFF**” to switch to have the LED display switch off after 10 seconds.
3. Press ENTER to confirm. To make you LED display reappear again press any button.

DISP - This function will reverse the display 180°.

1. Press the **MENU** button until “**DISP**” is displayed, press **ENTER**.
2. Press **ENTER** to “flip” the display. Press **ENTER** to “flip” it again. Press ENTER when you have made your desired setup.

TEST - This function will run a self test program.

1. Press the **MENU** button until “**TEST**” is displayed, press **ENTER**.
2. The fixture will now run a self test.

MANU - In this submenu you are able to test the different functions; pan, tilt, LEDs, zoom, dimmer, and strobe.

1. Press the **MENU** button until “**MANU**” is displayed, press **ENTER**.
2. Use the **UP** and **DOWN** buttons to scroll through the various functions able for testing. Once you have found your desired function you would like to test press **ENTER**.
3. After you have pressed **ENTER**, use the **UP** and **DOWN** buttons to adjust the values and test the function. To exit press the **MENU** button.

TEMP - With this function you can check the temperature of the fixture.

1. Press the **MENU** button until “**TEMP**” is displayed, press **ENTER**.
2. The fixture temperature will now be displayed. Press **MENU** to exit.

FHRS - With this function you can display the running time of the unit.

1. Press the **MENU** button until “**FHRS**” is displayed, press **ENTER**.
2. The running time of the fixture will now be displayed. Press **MENU** to exit.

VER - Use this function to display the Software version of the unit.

1. Press the either the **MENU** button until “**VER**” is displayed, press **ENTER**.
2. The display will show the software version.

RSET - Use this function to reset the unit.

1. Press the **MENU** button until “**RSET**” is displayed, press **ENTER**.
2. The fixture will now reset.

BALA - With this function you can adjust the RGB colors to make your desired color.

1. Press the **MENU** button until “**BALA**” is displayed, press **ENTER**.
2. Use the **UP** or **DOWN** buttons to find the color you wish to adjust.
3. Once you find the color you want to adjust press **ENTER**, the displayed value will begin to flash. Use the **UP** or **DOWN** buttons to adjust the value. Once you have made your adjustment press **ENTER**.
4. Repeat steps 2-3 until satisfied.

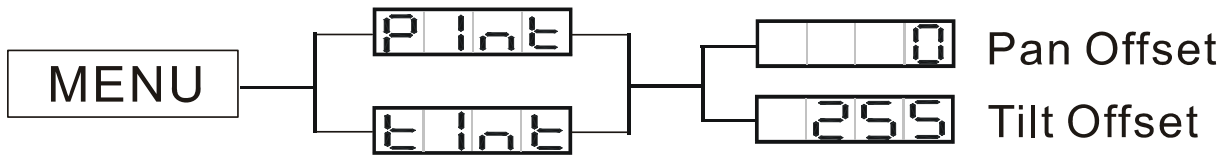

To enter the home position adjustment menu, unlock the display by pressing the **MODE** button for at least 3 seconds. Then press the **ENTER** button for at least 3 seconds to enter the home adjustment menu. In this submenu you are able to adjust the original position of the pan position and tilt position.

PINT - Adjustment of the pan position.

1. Press the **ENTER** button for at least 5 seconds, then press the **UP** or **DOWN** buttons so that “**PINT**” is displayed, press **ENTER**.
2. Use the **UP** and **DOWN** buttons to make your adjustments, and then press **ENTER** to confirm. Press the **MENU** button for one second to exit.

TINT - Adjustment of the tilt position.

1. Press the **ENTER** button for at least 5 seconds, then press the **UP** or **DOWN** buttons so that “**TINT**” is displayed, press **ENTER**.
2. Use the **UP** and **DOWN** buttons to make your adjustments, and then press **ENTER** to confirm. Press the **MENU** button for one second to exit.

Universal DMX Control: This function allows you to use a Elation® universal DMX-512 controller to control the chases and patterns, dimmer and strobe. A DMX controller allows you to create unique programs tailored to your individual needs.

1. The Inno Pocket Z4 has 3 DMX channel modes; 16 channel mode, 19 channel mode, and 22 channel mode. See pages 21-27 for detailed description of the DMX values and traits.
2. To control your fixture in DMX mode, follow the set-up procedures on pages 7-9 as well as the set-up specifications that are included with your DMX controller.
3. Use the controller's faders to control the various DMX fixture traits.
4. This will allow you to create your own programs.
5. Follow the instruction on page 11 to set the DMX address.
6. For longer cable runs (more than a 100 feet) use a terminator on the last fixture.
7. For help operating in DMX mode consult the manual included with your DMX controller.

Sound Active Mode: This mode allows either single unit or several units linked together, to run to the beat of the music.

1. Press the **MENU** button until "**SOUN**" is displayed, and press **ENTER**. Press the **UP** or **DOWN** buttons so that "**ON**" is displayed and press **ENTER**.
2. Press the **MENU** button until "**SENS**" is displayed, and press **ENTER**. Use the **UP** and **DOWN** buttons to adjust the sound sensitivity. Press **ENTER** when you have found your desired sensitivity level.

Show Mode: This mode allows either a single unit or several units linked together, to run one of four shows that you choose.

1. Press the **MENU** button until "**SHND**" is displayed, and press **ENTER**.
2. Press the **UP** or **DOWN** buttons to find your desired show, and press **ENTER**.

Primary-Secondary Operation This function will allow you to link up to 16 units together and operate without a controller. The units will be sound activated. In Primary-Secondary operation one unit will act as the controlling unit and the others will react to the controlling units programs. Any unit can act as a Primary or as a Secondary.

1. Using approved DMX data cables, daisy chain your units together via the XLR connector on the rear of the units. Remember the Male XLR connector is the input and the Female XLR connector is the output. The first unit in the chain (Primary) will use the female XLR connector only - The last unit in the chain will use the male XLR connector only. For longer cable runs we suggest a terminator at the last fixture.
2. On the Primary unit press the MENU button until “**ScND**” is displayed, and press ENTER. Use the UP and DOWN buttons to scroll to the “**Pr1**” setting and press ENTER.
3. After setting the Primary unit to the Primary setting find and set your desired operating mode.
4. On the Secondary units press the MENU button until “**ScND**” is displayed, and press ENTER. Choose either “**SEC1**” or “**SEC2**” and press ENTER. See page 11 for more info.
5. The Secondary units will now follow the Primary unit.

The **ADJ UC IR (sold separately)** infrared remote gives you control of various functions (See below). To control the fixture you must aim the remote at the front of the fixture and be no more than 30 feet away.

STAND BY - Pressing this button will blackout the fixture.

FULL ON - Hold this button down to fully light up the unit. When you let the button go, the unit will return to its previous state.

FADE/GOBO - Press this button to activate Fade mode.

“DIMMER +” and “DIMMER -” - Use these buttons to adjust the output intensity in Color mode.

STROBE - This button will activate the strobe effect. Press and hold this button to activate strobing and release the button to stop strobing.

COLOR - Press this button to enter Dimmer mode. Use the 1-9 buttons to select your desired color. Adjust the output intensity using the “DIMMER +” and “DIMMER -” buttons.

1-9 - In color mode, these buttons will allow you to select a desired color. In show mode, these buttons will allow you to select a desired show.

SOUND ON & OFF - These buttons activate and deactivate the sound active mode.

SHOW - This activates the show mode. Use buttons 1-4 to select your desired show.

Channel	Value	Function
1	0 - 255	PAN MOVEMENT 0°-540°
2	0 - 255	PAN FINE
3	0 - 255	TILT MOVEMENT 0°-180°
4	0 - 255	TILT FINE
5	0 - 255	RED 1 0% - 100%
6	0 - 255	GREEN 1 0% - 100%
7	0 - 255	BLUE 1 0% - 100%
8	0 - 255	WHITE 1 0% - 100%
9	0 - 255	RED 2 0% - 100%
10	0 - 255	GREEN 2 0% - 100%
11	0 - 255	BLUE 2 0% - 100%
12	0 - 255	WHITE 2 0% - 100%
13	0 - 255	ZOOM 10°- 60°
14		SHUTTER/STROBE
	0 - 7	CLOSED
	8 - 15	OPEN
	16 - 131	STROBING SLOW - FAST
	132 - 139	OPEN
	140 - 181	FAST CLOSE - SLOW OPEN
	182 - 189	OPEN
	190 - 231	SLOW CLOSE - FAST OPEN
	232 - 239	OPEN
	240 - 247	RANDOM STROBING
248 - 255	OPEN	
15	0 - 255	Primary DIMMER 0% - 100%
16		SPECIAL FUNCTIONS
	0 - 69	NO FUNCTION
	70 - 79	BLACKOUT W/ PAN/TILT MOVEMENT
	80 - 89	DISABLE BLACKOUT WITH PAN/TILT MOVEMENT
	90 - 199	NO FUNCTION
	200 - 209	RESET ALL
210 - 255	NO FUNCTION	

Channel	Value	Function
1	0 - 255	PAN MOVEMENT 0°-540°
2	0 - 255	PAN FINE
3	0 - 255	TILT MOVEMENT 0°-180°
4	0 - 255	TILT FINE
5	0 - 255	RED 1 0% - 100%
6	0 - 255	GREEN 1 0% - 100%
7	0 - 255	BLUE 1 0% - 100%
8	0 - 255	WHITE 1 0% - 100%
9	0 - 255	RED 2 0% - 100%
10	0 - 255	GREEN 2 0% - 100%
11	0 - 255	BLUE 2 0% - 100%
12	0 - 255	WHITE 2 0% - 100%
13		COLOR MACROS
	0 - 7	NO FUNCTION
	8 - 11	COLOR MACRO 1
	12 - 15	COLOR MACRO 2
	16 - 19	COLOR MACRO 3
	20 - 22	COLOR MACRO 4
	23 - 26	COLOR MACRO 5
	27 - 30	COLOR MACRO 6
	31 - 34	COLOR MACRO 7
	35 - 37	COLOR MACRO 8
	38 - 41	COLOR MACRO 9
	42 - 45	COLOR MACRO 10
	46 - 48	COLOR MACRO 11
	49 - 52	COLOR MACRO 12
	53 - 56	COLOR MACRO 13
	57 - 60	COLOR MACRO 14
	61 - 63	COLOR MACRO 15
	64 - 67	COLOR MACRO 16
	68 - 71	COLOR MACRO 17
	72 - 75	COLOR MACRO 18
	76 - 79	COLOR MACRO 19
	80 - 82	COLOR MACRO 20
	83 - 85	COLOR MACRO 21
	86 - 89	COLOR MACRO 22
	90 - 93	COLOR MACRO 23
	94 - 97	COLOR MACRO 24
	98 - 101	COLOR MACRO 25
	102 - 104	COLOR MACRO 26
	105 - 108	COLOR MACRO 27
	109 - 112	COLOR MACRO 28
	113 - 115	COLOR MACRO 29
	116 - 119	COLOR MACRO 30
120 - 123	COLOR MACRO 31	
124 - 127	COLOR MACRO 32	
128 - 191	COLOR CHANGING	
192 - 255	COLOR FADING	

Channel	Value	Function
14		COLOR CHANGE/FADE SPEED
	0 - 255	SLOW - FAST
15	0 - 255	ZOOM 10°- 60°
16		SHUTTER/STROBE
	0 - 7	CLOSED
	8 - 15	OPEN
	16 - 131	STROBING SLOW - FAST
	132 - 139	OPEN
	140 - 181	FAST CLOSE - SLOW OPEN
	182 - 189	OPEN
	190 - 231	SLOW CLOSE - FAST OPEN
	232 - 239	OPEN
	240 - 247	RANDOM STROBING
248 - 255	OPEN	
17	0 - 255	Primary DIMMER 0% - 100%
18		SPECIAL FUNCTIONS
	0 - 69	NO FUNCTION
	70 - 79	BLACKOUT W/ PAN/TILT MOVEMENT
	80 - 89	DISABLE BLACKOUT WITH PAN/TILT MOVEMENT
	90 - 199	NO FUNCTION
	200 - 209	RESET ALL
19		DIMMER CURVES
	0 - 20	STANDARD
	21 - 40	STAGE
	41 - 60	TV
	61 - 80	ARCHITECTURAL
	81 - 100	THEATRE
	101 - 255	DEFAULT DIMMER SETTING

Channel	Value	Function
1	0 - 255	PAN MOVEMENT 0°-540°
2	0 - 255	PAN FINE
3	0 - 255	TILT MOVEMENT 0°-180°
4	0 - 255	TILT FINE
5	0 - 255	RED 1 0% - 100%
6	0 - 255	GREEN 1 0% - 100%
7	0 - 255	BLUE 1 0% - 100%
8	0 - 255	WHITE 1 0% - 100%
9	0 - 255	RED 2 0% - 100%
10	0 - 255	GREEN 2 0% - 100%
11	0 - 255	BLUE 2 0% - 100%
12	0 - 255	WHITE 2 0% - 100%
13		COLOR MACROS
	0 - 7	NO FUNCTION
	8 - 11	COLOR MACRO 1
	12 - 15	COLOR MACRO 2
	16 - 19	COLOR MACRO 3
	20 - 22	COLOR MACRO 4
	23 - 26	COLOR MACRO 5
	27 - 30	COLOR MACRO 6
	31 - 34	COLOR MACRO 7
	35 - 37	COLOR MACRO 8
	38 - 41	COLOR MACRO 9
	42 - 45	COLOR MACRO 10
	46 - 48	COLOR MACRO 11
	49 - 52	COLOR MACRO 12
	53 - 56	COLOR MACRO 13
	57 - 60	COLOR MACRO 14
	61 - 63	COLOR MACRO 15
	64 - 67	COLOR MACRO 16
	68 - 71	COLOR MACRO 17
	72 - 75	COLOR MACRO 18
	76 - 79	COLOR MACRO 19
	80 - 82	COLOR MACRO 20
	83 - 85	COLOR MACRO 21
	86 - 89	COLOR MACRO 22
	90 - 93	COLOR MACRO 23
	94 - 97	COLOR MACRO 24
	98 - 101	COLOR MACRO 25
	102 - 104	COLOR MACRO 26
	105 - 108	COLOR MACRO 27
	109 - 112	COLOR MACRO 28
	113 - 115	COLOR MACRO 29
	116 - 119	COLOR MACRO 30
120 - 123	COLOR MACRO 31	
124 - 127	COLOR MACRO 32	
128 - 191	COLOR CHANGING	
192 - 255	COLOR FADING	

Channel	Value	Function
14		COLOR CHANGE/FADE SPEED
	0 - 255	SLOW - FAST
15		PAN/TILT MACROS
	0 - 15	NO FUNCTION
	16 - 35	MACRO 1
	36 - 55	MACRO 2
	56 - 75	MACRO 3
	76 - 95	MACRO 4
	96 - 115	MACRO 5
	116 - 135	MACRO 6
	136 - 155	MACRO 7
	156 - 175	MACRO 8
	176 - 195	MACRO 9
	196 - 215	MACRO 10
	216 - 235	MACRO 11
	236 - 255	MACRO 12
16		PAN/TILT MACRO SPEED
	0 - 255	SLOW - FAST
17	0 - 255	ZOOM 10° - 60°
18		SHUTTER/STROBE
	0 - 7	CLOSED
	8 - 15	OPEN
	16 - 131	STROBING SLOW - FAST
	132 - 139	OPEN
	140 - 181	FAST CLOSE - SLOW OPEN
	182 - 189	OPEN
	190 - 231	SLOW CLOSE - FAST OPEN
	232 - 239	OPEN
	240 - 247	RANDOM STROBING
248 - 255	OPEN	
19	0 - 255	PRIMARY DIMMER 0% - 100%
20		PAN/TILT MOVEMENT SPEED
	0 - 255	FAST - SLOW
21		SPECIAL FUNCTIONS
	0 - 69	NO FUNCTION
	70 - 79	BLACKOUT W/ PAN/TILT MOVEMENT
	80 - 89	DISABLE BLACKOUT WITH PAN/TILT MOVEMENT
	90 - 199	NO FUNCTION
	200 - 209	RESET ALL
	210 - 255	NO FUNCTION
22		DIMMER CURVES
	0 - 20	STANDARD
	21 - 40	STAGE
	41 - 60	TV
	61 - 80	ARCHITECTURAL
	81 - 100	THEATRE
	101 - 255	DEFAULT DIMMER SETTING

Beam angle 10°

R	3510	958	435	243	160	(lux)
G	9065	2365	1051	627	406	
B	386	108	58	38	30	
W	9378	2445	1077	648	410	
RGBW	21210	5731	2581	1431	950	

Beam angle 60°

R	322	92	52	35	27	(lux)
G	840	229	113	72	52	
B	46	20	17	15	13	
W	846	233	116	73	52	
RGBW	1885	541	261	153	102	

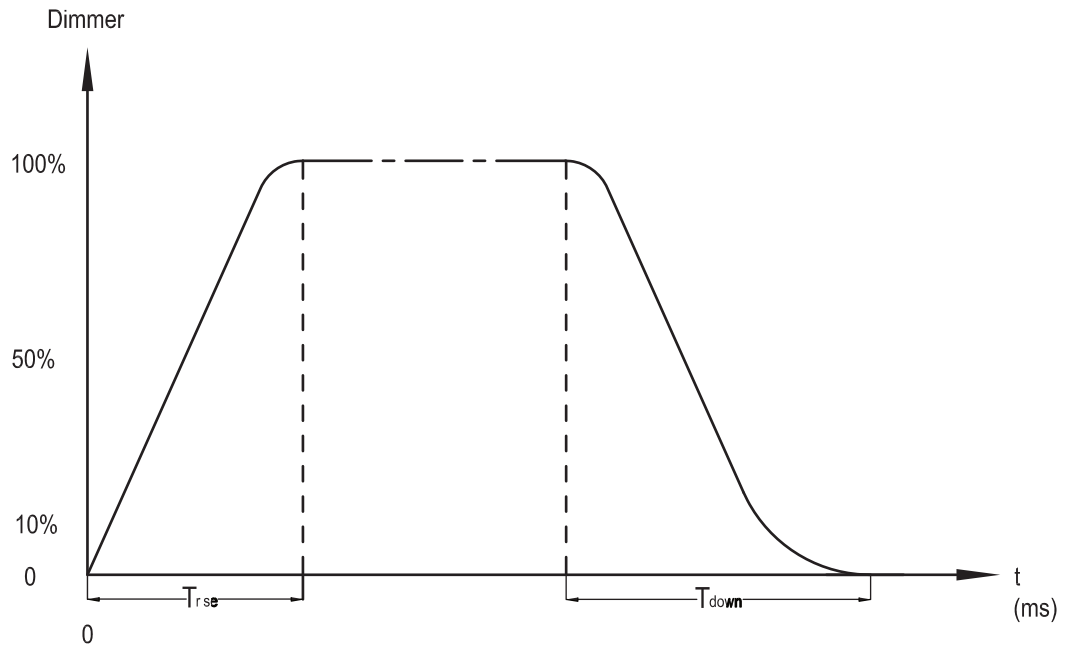
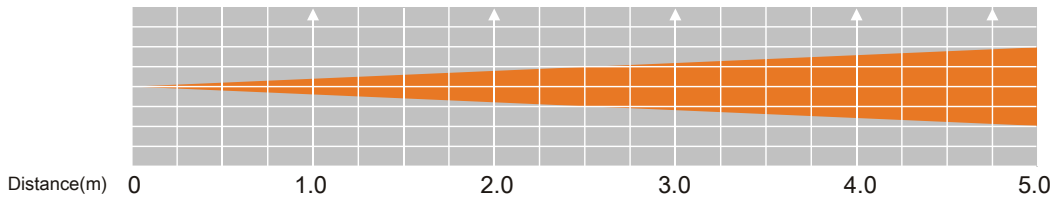

Ramp Effect	0 $\overset{255}{\curvearrowright}$ OS		0 $\overset{255}{\curvearrowright}$ 1S (Fade Time)	
	T_{rise} (ms)	T_{down} (ms)	T_{rise} (ms)	T_{down} (ms)
Standard	0	0	0	0
Stage	780	1100	1540	1660
TV	1180	1520	1860	1940
Architectura	1380	1730	2040	2120
I Theatre	1580	1940	2230	2280

Locate and remove the unit's power cord. Once the cord has been removed locate the fuse holder located inside the power socket. Insert a flat-head screw driver into the power socket and gently pry out the fuse holder. Remove the bad fuse and replace with a new one. The fuse holder has a built-in socket for a spare fuse be sure not to confuse the spare fuse with active fuse.

Due to fog residue, smoke, and dust cleaning the internal and external optical lenses and mirror should be carried out periodically to optimize light output. Cleaning frequency depends on the environment in which the fixture operates (i.e. smoke, fog residue, dust, dew). In heavy club use we recommend cleaning on a monthly basis. Periodic cleaning will ensure longevity, and crisp output.

1. Use normal glass cleaner and a soft cloth to wipe down the outside casing.
2. Use a brush to wipe down the cooling vents and fan grill.
3. Clean the external optics with glass cleaner and a soft cloth every 20 days.
4. Clean the internal optics with glass cleaner and a soft cloth every 30-60 days.
5. Always be sure to dry all parts completely before plugging the unit back in.

Trouble Shooting: Listed below are a few common problems that you may encounter, with solutions.

No light output from the unit;

1. Be sure the external fuse has not blown. The fuse is located on the rear panel of the unit.
2. Be sure the fuse holder is completely and properly seated.

Unit does not respond to sound;

1. Low frequencies (bass) should cause the unit to react to sound. Tapping on the microphone, quiet or high pitched sounds may not activate the unit.

MANUFACTURER'S LIMITED WARRANTY

- A. ADJ Products, LLC hereby warrants, to the original purchaser, ADJ Products, LLC products to be free of manufacturing defects in material and workmanship for a prescribed period from the date of purchase (see specific warranty period on reverse). This warranty shall be valid only if the product is purchased within the United States of America, including possessions and territories. It is the owner's responsibility to establish the date and place of purchase by acceptable evidence, at the time service is sought.
- B. For warranty service you must obtain a Return Authorization number (RA#) before sending back the product—please contact ADJ Products, LLC Service Department at 800-322-6337. Send the product only to the ADJ Products, LLC factory. All shipping charges must be pre-paid. If the requested repairs or service (including parts replacement) are within the terms of this warranty, ADJ Products, LLC will pay return shipping charges only to a designated point within the United States. If the entire instrument is sent, it must be shipped in its original package. No accessories should be shipped with the product. If any accessories are shipped with the product, ADJ Products, LLC shall have no liability whatsoever for loss of or damage to any such accessories, nor for the safe return thereof.
- C. This warranty is void if the serial number has been altered or removed; if the product is modified in any manner which ADJ Products, LLC concludes, after inspection, affects the reliability of the product; if the product has been repaired or serviced by anyone other than the ADJ Products, LLC factory unless prior written authorization was issued to purchaser by ADJ Products, LLC; if the product is damaged because not properly maintained as set forth in the instruction manual.
- D. This is not a service contract, and this warranty does not include maintenance, cleaning or periodic check up. During the period specified above, ADJ Products, LLC will replace defective parts at its expense with new or refurbished parts, and will absorb all expenses for warranty service and repair labor by reason of defects in material or workmanship. The sole responsibility of ADJ Products, LLC under this warranty shall be limited to the repair of the product, or replacement thereof, including parts, at the sole discretion of ADJ Products, LLC. All products covered by this warranty were manufactured after August 15, 2012, and bear identifying marks to that effect.
- E. ADJ Products, LLC reserves the right to make changes in design and/or improvements upon its products without any obligation to include these changes in any products theretofore manufactured.

No warranty, whether expressed or implied, is given or made with respect to any accessory supplied with products described above. Except to the extent prohibited by applicable law, all implied warranties made by ADJ Products, LLC in connection with this product, including warranties of merchantability or fitness, are limited in duration to the warranty period set forth above. And no warranties, whether expressed or implied, including warranties of merchantability or fitness, shall apply to this product after said period has expired. The consumer's and/or Dealer's sole remedy shall be such repair or replacement as is expressly provided above; and under no circumstances shall ADJ Products, LLC be liable for any loss or damage, direct or consequential, arising out of the use of, or inability to use, this product.

This warranty is the only written warranty applicable to ADJ Products, LLC Products and supersedes all prior warranties and written descriptions of warranty terms and conditions heretofore published.

MANUFACTURER'S LIMITED WARRANTY PERIODS:

- **Lighting Products= 1-year (365 days) Limited Warranty** (Such as: Special Effect Lighting, Intelligent Lighting, UV lighting, Strobes, Fog Machines, Bubble Machines, Mirror Balls, Par Cans, Trussing, Lighting Stands etc. excluding LED and lamps)
- **Laser Products= 1 Year (365 Days) Limited Warranty** (excluding laser diodes which have a 6 month limited warranty)
- **L.E.D. Products= 2-year (730 days) Limited Warranty** (excluding motors, PCB boards, and power supplies, which have a 1-year (365 day Limited Warranty) batteries which have a 180 day limited warranty). Only the L.E.D.s carry a 2-year warranty (**excluding StarTec Series, which carries a 1 Year Limited Warranty**)
- **ADJ DMX Controllers= 2 Year (730 Days) Limited Warranty** (excluding faders and tact switches)

Voltage:	100 - 240V, 50/60Hz
LED:	4 x 10W 4-in-1 RGBW LEDs
Power Consumption:	67W
Dimensions:	5.5”(L) x 6.75”(W) x 9.75”(H) 141 x 174 x 247mm
Weight:	7 Lbs. / 3.2 kgs.
Angle:	10 - 60 Degrees
Fuse:	3.15 Amp
Duty Cycle:	None
DMX:	3 DMX Channel Modes: 16/19/22
Colors:	RGBW Color Mixing
Sound Active:	Yes
Working Position:	Any Safe, Secure Position
Warranty:	2 Year (730 days)

Please Note: Specifications and improvements in the design of this unit and this manual are subject to change without any prior written notice.

Auto Sensing Voltage: This fixture contains a automatic voltage switch, which will auto sense the voltage when it is plugged into the power source.

ADJ Products, LLC 6122 S. Eastern Ave. Los Angeles, CA
90040 USA Tel: 323-582-2650 / Fax: 323-725-6100 Web:
www.adj.com / E-mail: info@americandj.com

Follow Us On:



facebook.com/americandj
twitter.com/americandj
youtube.com/adjlighting

A.D.J. Supply Europe B.V.
Junostraat 2
6468 EW Kerkrade
Netherlands
service@adjgroup.eu / www.adj.eu Tel: +31 45 546 85 00
/ Fax: +31 45 546 85 99

